

Weishaupt Gas burners model "G" Combination Gas/Oil burners models "GL" and "RGL" Sizes 5 to 11

–weishaupt–

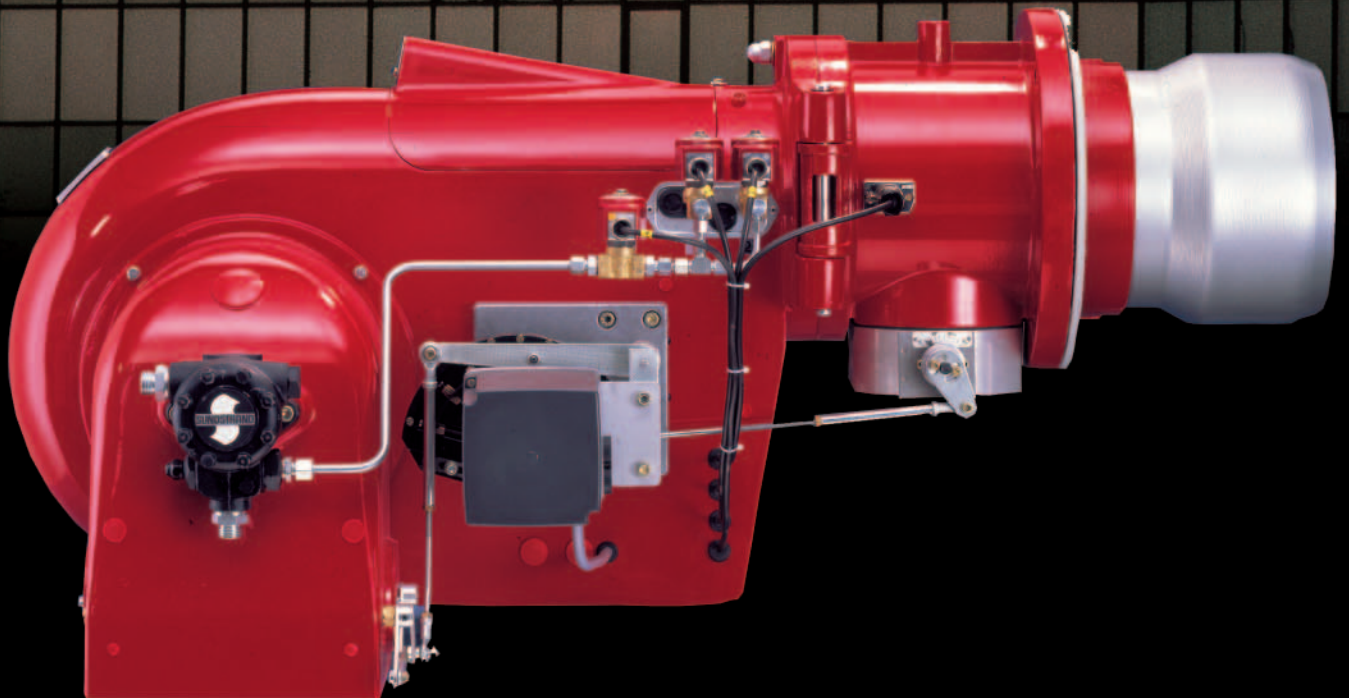

Description

The Weishaupt Research and Development Institute was established in 1962 with the aim to develop exceptional products in terms of quality and performance. This commitment was made at a time when the concepts of “energy savings” and “environmental protection” were not yet considered issues of social and political importance.

The Weishaupt company and its products are founded on the principles of quality design and performance.

- Certified to international quality standard ISO 9001
- Listed by ETL (UL795/296) and CGA
- Annual sales in excess of 150,000 burners

Burner Design

- Forced draft automatic burner
- Cast aluminum, hinged monobloc design
- Burner swings open to the left or right
- Stainless steel flame tube capable of withstanding temperatures up to 1450° F
- Precision cam arrangement controls the fuel and combustion air
- Single servomotor drives the cam arrangement and controls the individual set point for:
 - High fire position gas/oil
 - Air damper closed
 - Ignition position gas
 - Ignition position oil (RGL)
 - Low fire position gas
 - Low fire position oil (RGL)
 - Stage 2 oil solenoid (GL)
 - Low fire position gas/oil (GL)

Gas Trains

Weishaupt Gas and Combination Gas/Oil burners are always supplied with two (2) safety shut off valves in both the pilot and main gas trains.

Burner Version and Capacity Regulation

Gas models “G”

- Low/High/Low version ZD controlled by a servomotor with a running time of 8 seconds
- Modulating version ZMD controlled by a servomotor with a running time of 42 seconds

Combination Gas/Oil models “GL”

- Low/High/Low gas/oil version ZD controlled by a servomotor with a running time of 8 seconds

- Modulating gas, Low/High/Low oil version ZMD controlled by a servomotor with a running time of 20 seconds
- Modulating gas, three (3) stage oil version TMD controlled by a servomotor with a running time of 20 seconds

Combination Gas/Oil models “RGL”

- Modulating gas/Modulating oil version ZMD controlled by a servomotor with a running time of 42 seconds

Description of Operation

Gas burners (G) supplied in the version ZD provide a rapid change from low fire to high fire via the 8 seconds servomotor. The cam arrangement controls the air damper and the gas butterfly throughout the firing range.

Gas burners (G) supplied in the version ZMD provide a slow change from low fire to high fire via the 42 seconds servomotor. The cam arrangement controls the air damper and the gas butterfly throughout the firing range.

Combination gas/oil burners (GL) supplied in the version ZD provide a rapid change from low fire to high fire via the 8 seconds servomotor. The cam arrangement controls the air damper and the gas butterfly throughout the firing range. The low fire (stage 1) and high fire (stage 2) oil nozzle solenoid valves are controlled by micro switch set points on the servomotor, which permit precise adjustment of fuel and air.

Combination gas/oil burners (GL) supplied in the version ZMD provide a relatively slow change from low fire to high fire via the 20 seconds servomotor. The cam arrangement controls the air damper and the gas butterfly throughout the firing range. The low fire (stage 1) and high fire (stage 2) oil nozzle solenoid valves are controlled by micro switch set points on the servomotor, which permit precise adjustment of fuel and air.

Combination gas/oil burners (GL) supplied in the version TMD provide a relatively slow change from low fire to high fire via the 20 seconds servomotor. The cam arrangement controls the air damper and the gas butterfly throughout the firing range. The low fire (stage 1), second stage (stage 2) and high fire

(stage 3) oil nozzle solenoid valves are controlled by micro switch set points on the servomotor and air louver cam, which permit precise adjustment of fuel and air. Combination gas/oil burners (RGL) are supplied in the version ZMD and provide a slow change from low fire to high fire via the 42 seconds servomotor. The cam arrangement controls the air damper, oil regulating valve and the gas butterfly throughout the firing range.

Controlled shut down

The control system is designed to ensure a controlled shut down of the burner at the low fire position.

Ignition position

Burner models “G” and “GL” provide an independent ignition position, in addition to the low fire position, when firing on gas.

Burner model “RGL” provides a separate ignition position and separate low fire positions for both gas and oil.

This feature permits the burner to be tuned to the appliance, allowing only a very small quantity of gas (or oil) to be released on light off.

Flame supervision

Standard methods of flame monitoring are:

- a flame rod for Gas
- a UV scanner for Combination Gas/Oil

Flame Monitoring Systems

The burner flame monitor sequences and controls the operation of the burner automatically. The flame monitor can be located in either the burner control panel or mounted directly on the burner. The standard flame monitoring system used is manufactured by Landis & Staefa.

Alternative flame monitoring systems utilizing configurations of the Honeywell 7800 series and Fireye E 110 are available upon request.

Magnetic clutch

The coupling between the oil pump and the motor shaft is automatically disconnected when operating on gas, protecting the pump from unnecessary wear (standard on “RGL” and “GL” 9, optional on “GL” 1–8).



1



2

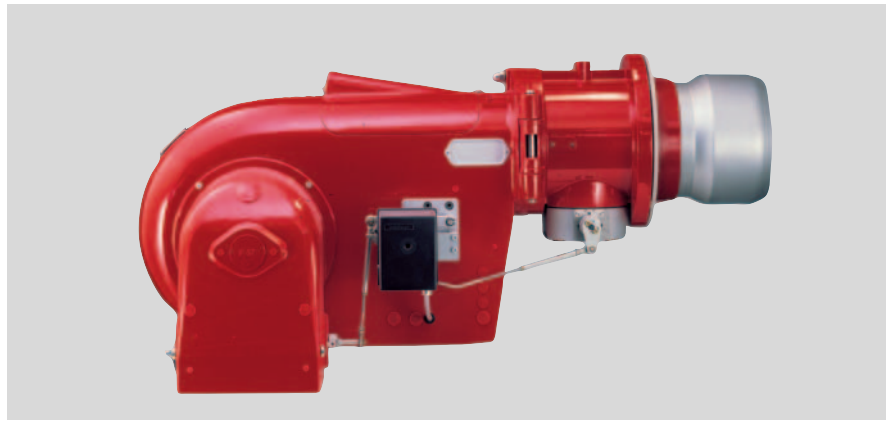

3

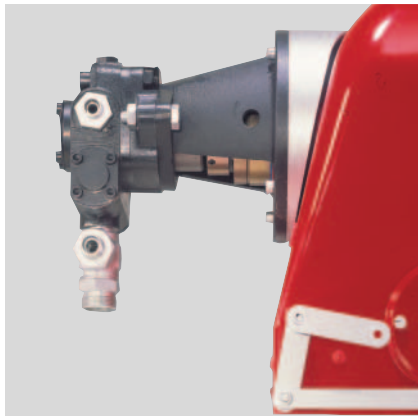

4

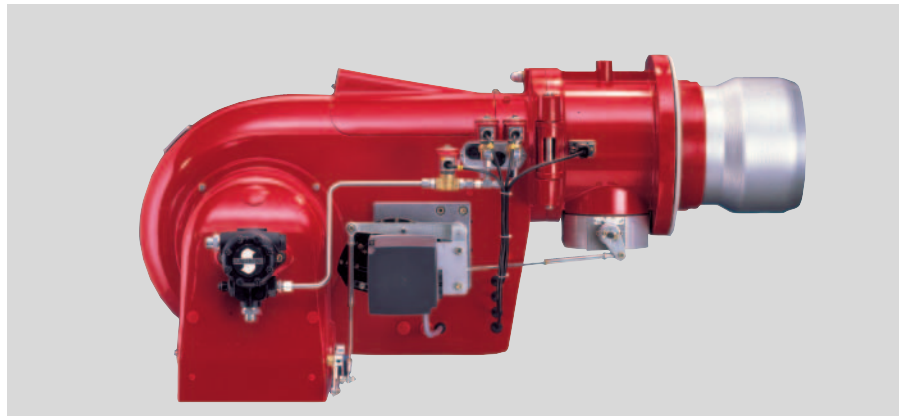

5

- 1 Gas Burner "G" version ZMD:**
- Weishaupt manufactured high efficiency motor
 - Stainless steel flame tube and diffuser designed to withstand temperatures up to 1450°F
 - The gas butterfly is an integrated component
 - Single servomotor controls both the combustion air and fuel of all gas and combination gas/oil burners.
- 2 Gas burner "G" with ISG:**
- Burner mounted flame safeguard (Landis & Staefa LFL 1.335)
 - Air pressure switch

- 3 Gas burner "G" version ZD:**
- Servomotor model 1055 for rapid capacity change (8 seconds)
- 4 Magnetic Clutch:**
- Coupling between the oil pump and motor shaft
- 5 Combination Gas/Oil burner "GL" version ZMD:**
- Servomotor model SQM for slow capacity change
 - UV flame monitoring system.

Typical gas train schematic for burner with pilot

- 1 Isolating valve
- 2 Main gas pressure regulator
- 3 Low gas pressure switch
- 4 Double main gas valves
- 4b Double pilot gas valves
- 5 High gas pressure switch
- 6 Pilot isolating valve
- 7 Pilot gas pressure regulator
- 8 Integrated gas butterfly valve
- 9 Burner

Note

The actual gas train arrangement may differ depending on applicable code and regulation

Gas train with pilot

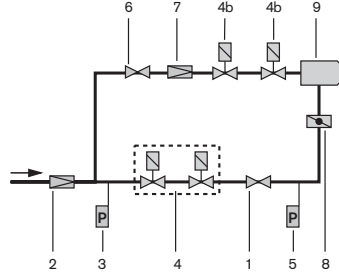

Gas train without pilot

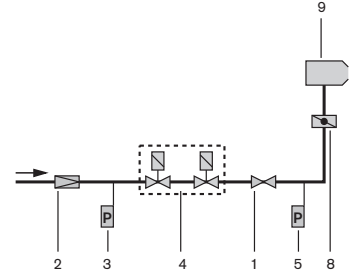

1

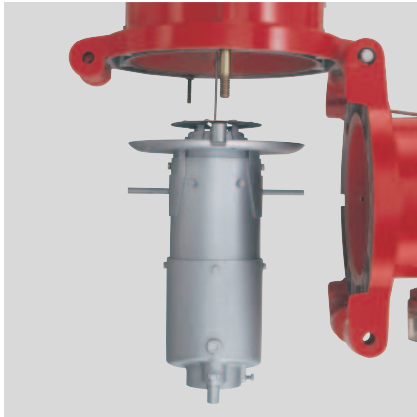

2

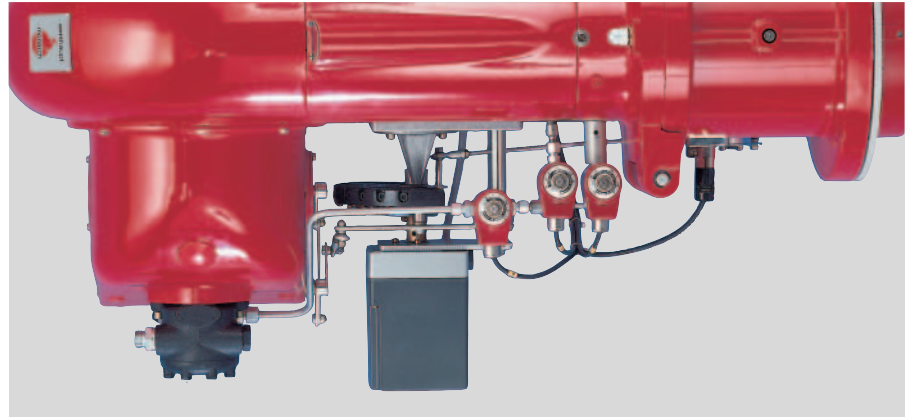

3



4

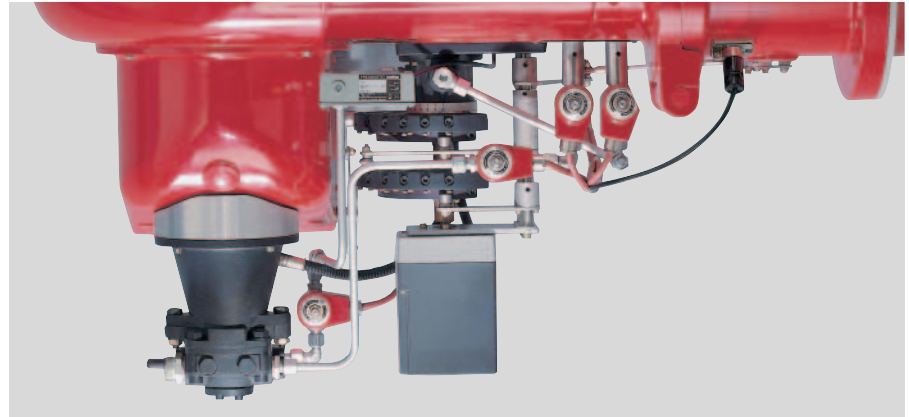

5

1 Gas Train assembly:

- Diagrams show typical assemblies. (When placing an order, state the applicable code required.)

2 Hinged flange:

- Allows the burner to swing open to the left or to the right, allowing easy access for servicing.

3 Combination Gas/Oil burner "GL" version ZMD:

- Single cam design. Start up gas first, tuning the air to the gas, the oil is adjusted second.
- Select oil nozzle/pump pressure and adjust micro switch on servomotor for precise oil/air mixture.
- A single allen screw holds the combustion head components securely in place.
- Three (3) solenoid valves – one for each oil nozzle plus one for safety.

4

4 Adjustable Flame Tube:

- Flame tube can be adjusted to suit the required capacity, maximizing the performance of the burner and increasing the turndown and efficiency.

5 Combination Gas/Oil burner "RGL" version ZMD:

- Two cam design. Start up oil first, tuning the air cam to the oil, set up gas second, tuning the gas cam to the pre-set air.
- Four (4) solenoid valves – 2 in the supply and 2 in the return, connected in series for added safety.
- Oil regulating valve, nozzle and pump pressure determine the burner capacity.

Types of Regulation

– weishaupt –

Capacity regulation – Gas Low/High/Low version ZD

- At ignition position, a controlled amount of gas is released from either the pilot or main gas train. After a pre-determined time delay, gas is released for the main flame.
- The burner provides a rapid change from low fire to high fire via the 8 second servomotor.



HF = High Fire
LF = Low Fire
IP = Ignition position

Capacity regulation – Gas Modulating version ZMD

- At ignition position, a controlled amount of gas is released from either the pilot or main gas train. After a pre-determined time delay, gas is released for the main flame.
- The burner provides a slow change from low fire to high fire via the 20 or 42 second servomotor.
- The modulating controller drives the servomotor up or down and allows the servomotor to stop in any position between low and high fire.

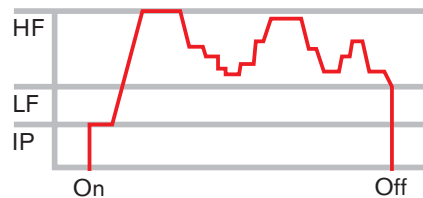

HF = High Fire
LF = Low Fire
IP = Ignition position

Capacity regulation – Oil Low/High/Low version ZD and Three Stage version TMD

- At low fire (stage 1), oil is released by energizing the stage 1 solenoid valve. High fire is achieved by energizing both the stage 1 and stage 2 solenoid valves (ZD).
- Three stage burners are supplied with three oil solenoids, stage 1, 2 and 3. At low fire (stage 1), the stage 1 solenoid is energized. Stage 2 is achieved by energizing both the stage 1 and stage 2 solenoid valves. Stage 3 (high fire) requires energizing all three solenoid valves.

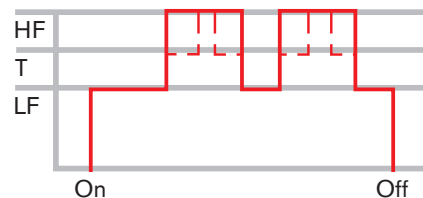

HF = High Fire
T = Stage 2 (TMD only)
LF = Low Fire

Capacity regulation – Oil Modulating version ZMD

- Similar to the gas burners, there is a separate ignition position for oil.
- At ignition position, a pre-determined amount of oil is released from the nozzle by energizing the solenoid valves (size RGL5 to RGL 7) or by energizing the solenoid valve and needle valve (size RGL8 to RGL 11).
- The burner provides a slow change from low fire to high fire via the 20 or 42 second servomotor.
- The modulating controller drives the servomotor up or down and allows the servomotor to stop in any position between low and high fire.

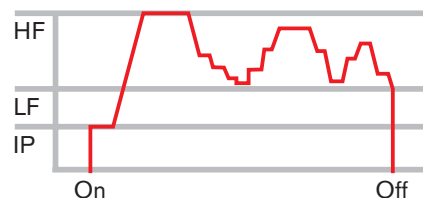

HF = High Fire
LF = Low Fire
IP = Ignition position

Burner selection – Gas model “G”

The capacity graphs are representative of tests performed under conditions as stated below.

The minimum firing rate may vary from application to application. In certain cases, a greater turn down ratio is possible.

Notes:

1. N = Natural Gas
P = Propane
S = Manufactured gas
2. For digester (sewer) or manufactured gas, the capacity graphs must be reduced by 10%.
Gas must be DRY!
3. If Flue Gas Recirculation (FGR) or Oxygen Trim (O₂) is added as an option, the maximum capacity of the burner must be reduced by the following factors:

Reduction	System
10%	FGR
15%	Oxygen trim
25%	FGR + Oxygen trim

(Consult a Weishaupt representative to verify the correct burner selection.)

Test Criteria:

All figures relate to an ambient temperature of 70°F (20°C) and a site elevation of 1,650 ft (500m) above sea level.

The capacity graphs are based on fuel with low calorific value.

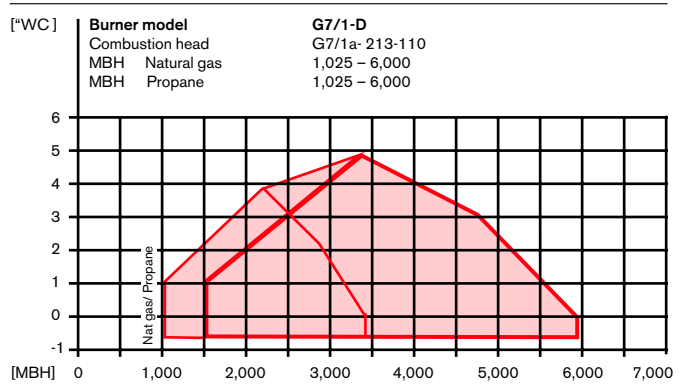
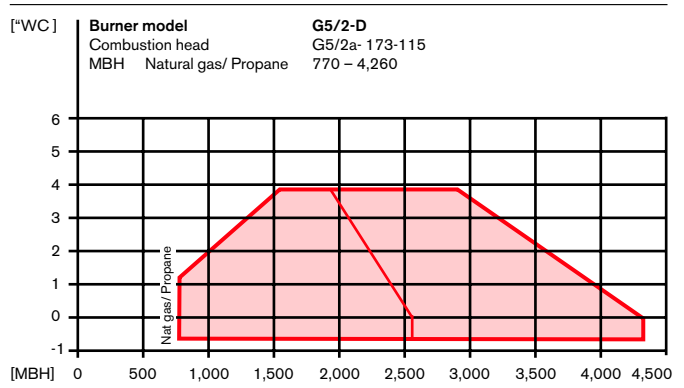
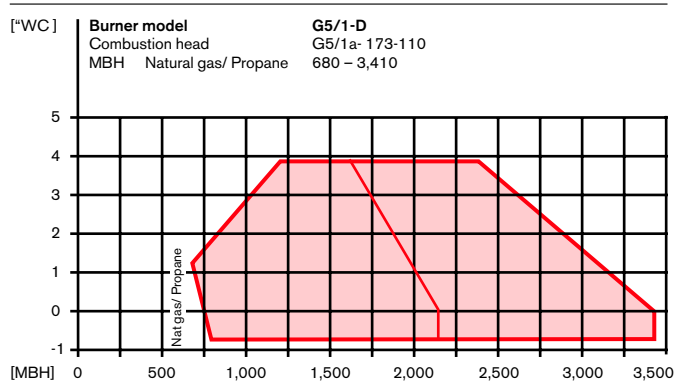

— Combustion head “open”
- - - Combustion head “closed”

Burner selection – Gas model “G”

– weishaupt –

Specification Features

- Cast aluminum burner housing, hinged monobloc design
- Burner can swing open to the left or right.
- Diffuser, ignition electrodes and gas mixing assembly are easily accessible and can be removed without removing the burner.
- Removable top cover for ease of service.
- Finished high-gloss, baked enamel coating.
- Burner incorporates a stainless steel alloy, flame retention type combustion head.
- Flame tube is a one piece construction, capable of withstanding temperatures of up to 1,450° F.
- A permanent observation port is provided to permit observation of the flame.
- The air damper drives to the fully closed position during off cycles to prevent standby losses (position can be adjusted if post-purge or continuous run is required).
- The gas butterfly valve is an integral part of the burner, mounted directly on the burner housing. The butterfly valve is spring loaded to fully close the valve, if the drive linkage is disconnected.
- The capacity regulation is controlled through the entire burner range by a single servodrive, equipped with individually adjustable micro switches, which enable the service technician to easily adjust the following:
 - controlled shut down (damper closed)
 - ignition gas
 - low fire gas
 - high fire gas
- All servomotor micro switches are independently adjustable to any setting from fully closed at 0% to fully open at 100%.
- The servodrive is integrally linked to the gas butterfly valve and combustion air control damper via a single cam.
- The air/fuel ratio can be adjusted at several points between low and high fire, precisely controlling the air/fuel ratio.
- The burner is equipped with a TEFC high-efficiency, maintenance free blower motor.
- The motor (size dependent) can be started via star-delta. The combustion air fan is dynamically balanced.
- Weishaupt burners are certified to the international standard ISO 9001.

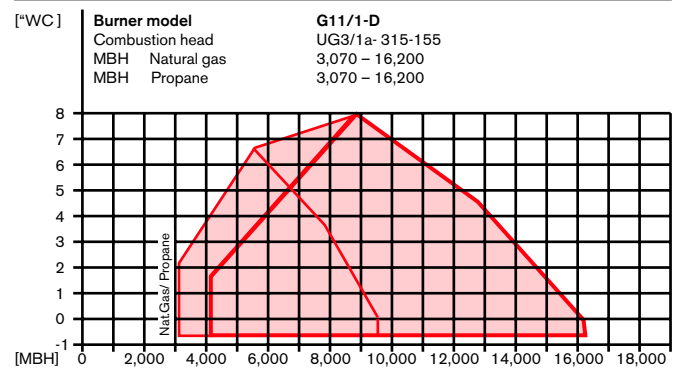
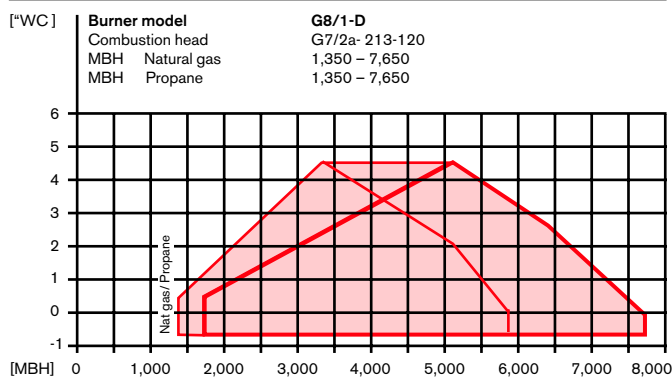
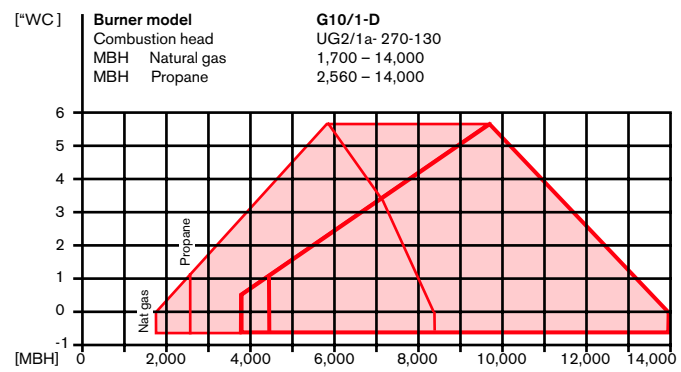
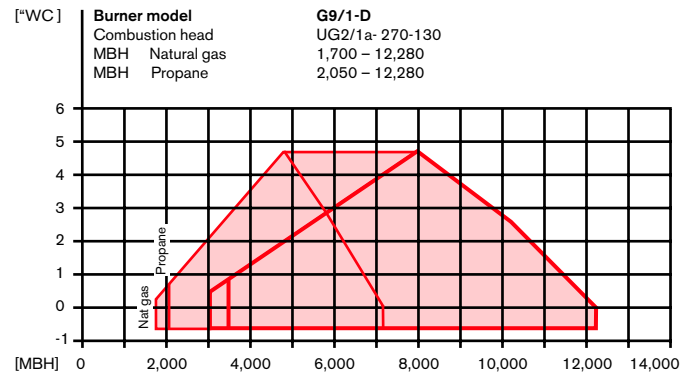

— Combustion head “open”
 - - - Combustion head “closed”

Burner selection – Combination Gas/Oil models “GL” and “RGL”

The capacity graphs are representative of tests performed under conditions as stated below.

The minimum firing rate may vary from application to application. In certain cases, a greater turn down ratio is possible.

Test Criteria:

All figures relate to an ambient temperature of 70°F (20°C) and a site elevation of 1,650 ft (500m) above sea level.

The capacity graphs are based on fuel with low calorific value.

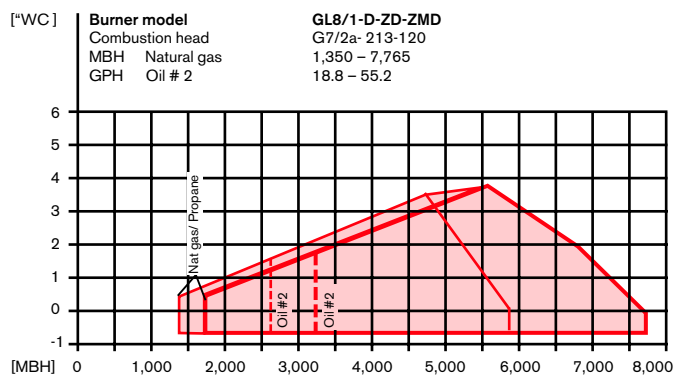
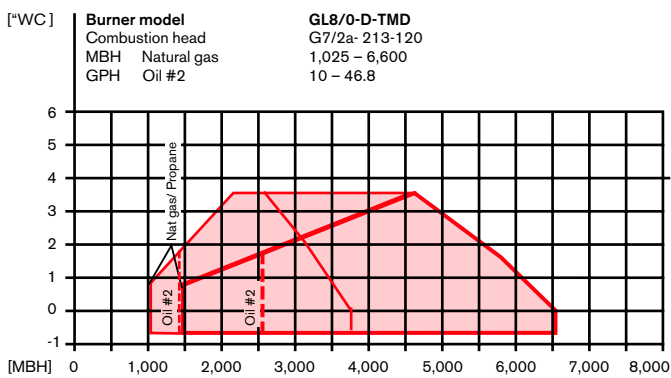
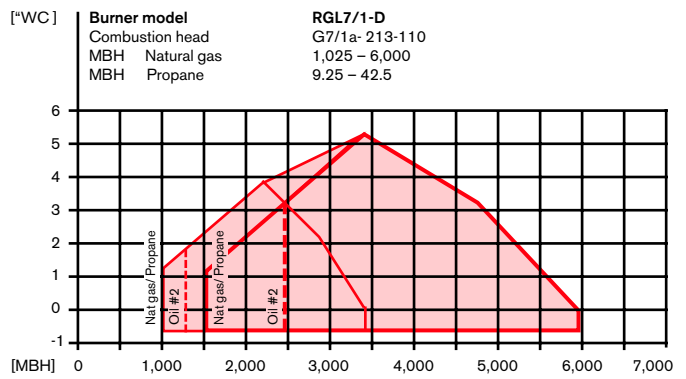
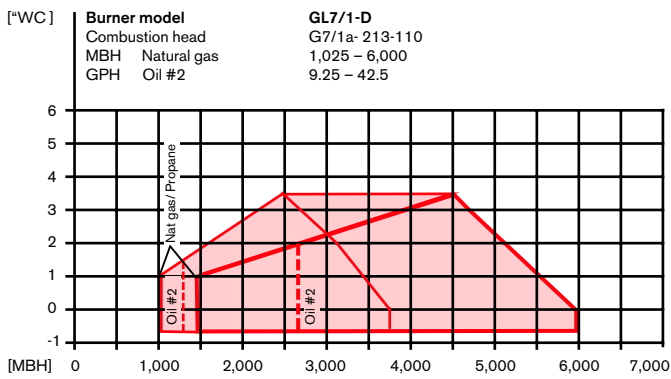
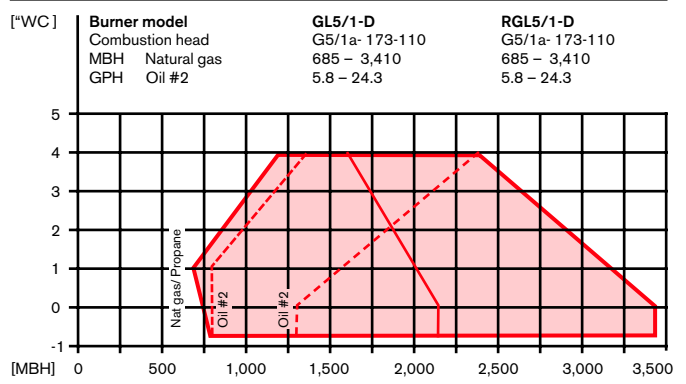

— Combustion head “open”
 - - - Combustion head “closed”

Burner selection - Combination Gas/Oil models "GL" and "RGL"

-weishaupt-

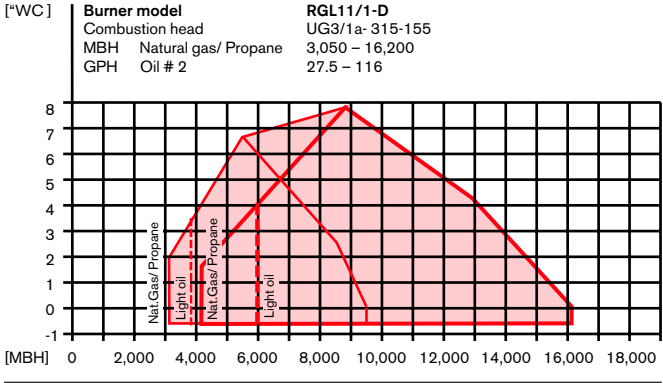
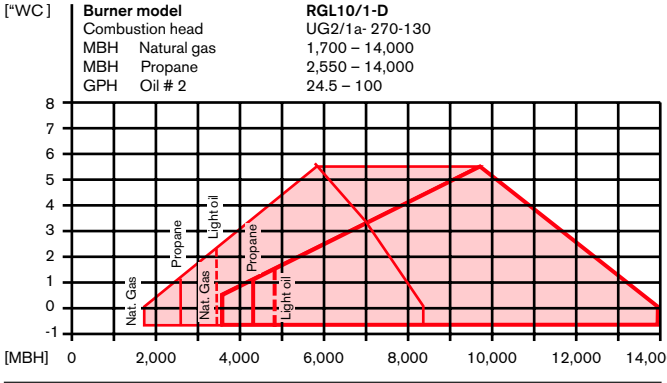
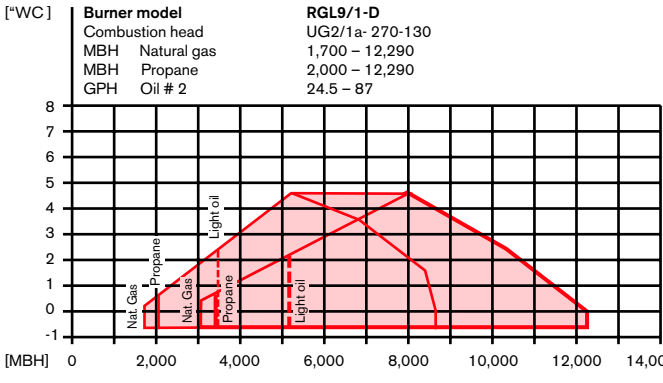
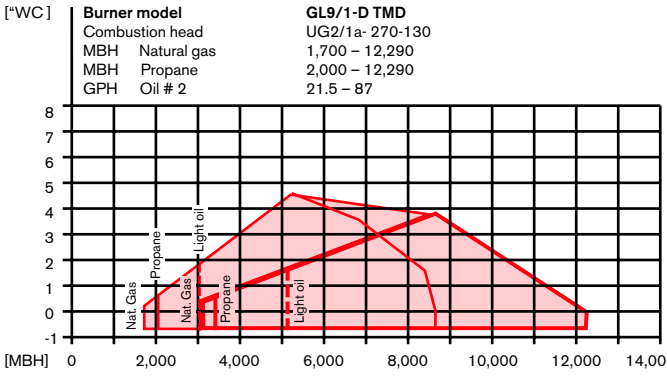
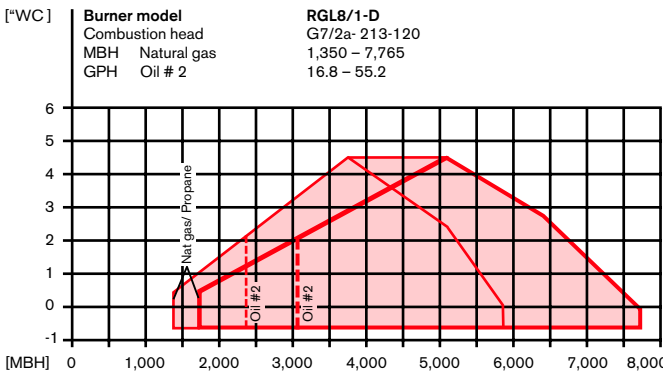
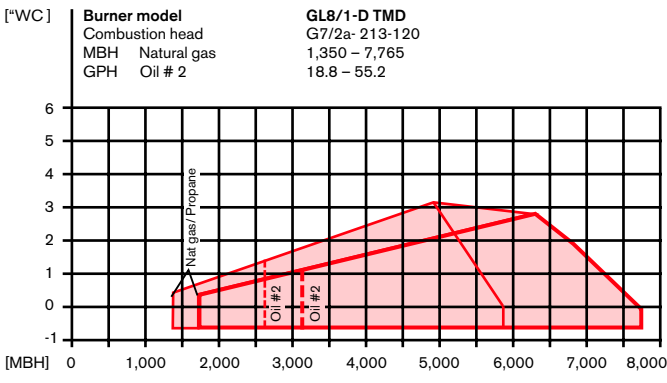

— Combustion head "open"
 — Combustion head "closed"

Included with the standard scope of supply

Accessory Equipment

Burner Model	G5-G8 Z	G5-G11ZM	GL5-GL8 Z	GL5-GL9ZM GL8-GL9TM	RGL5-RGL11
Number of gas safety shut of valves in pilot train (if applicable) and main gas train.	2	2	2	2	2
Burner casing, hinged flange, sight glass, Weishaupt burner motor, air damper, fan, air pressure switch, servomotor, cam(s), combustion head, ignition transformer cable and electrodes, terminal strip, flange gasket, mounting kit.	●	●	●	●	●
Hinged interlock switch	●	●	●	●	●
Burner control Landis & Staefa LFL (flame monitoring system) c/w flame rod.	●	●			
Burner control Landis & Staefa LFL (flame monitoring system) c/w UV scanner.			●	●	●
Oil pump, solenoid valves, nozzle(s) oil hoses			●	●	●
Oil/air adjustment cam					●
Oil pressure switch (in return line)					●
Magnetic clutch (standard on RGL burners, optional on GL except size 9)				●	●

Accessory Equipment (Subject to additional prices)

Description		G5 GL5 RGL5	G7 GL7 RGL7	G8 GL8 RGL8	G9 GL9 RGL9	G10 RGL10	G11 RGL11	
Downward firing (or any other position)		Standard	Standard	Standard	Standard	Standard	Standard	
Air intake flange (to duct combustion air)		110 001 05	110 001 06	110 001 06	110 002 77	110 002 77	110 002 77	
Pump J7 in place of J6, from 58 USG/hr (200kg/hr)	GL	-	-	-	110 015 43	-	-	
Pump TA2 in place of J6, from 72 USG/hr (250kg/hr)	GL	-	-	-	150 005 15	-	-	
Pump E6 in place of J6, main ring pressure > 29 PSI (2 bar)	GL	110 017 22	110 017 22	110 017 22	110 017 22	-	-	
Pump E6 in place of J6, main ring pressure > 29 PSI (2 bar)	RGL	110 017 22	-	-	-	-	-	
Pump E7 in place of J7, main ring pressure > 29 PSI (2 bar)	GL	-	-	-	110 015 44	-	-	
Oil hoses 51" (1300mm) in place of 39" (1000mm)	GL	150 000 47	150 000 47	150 000 47	150 000 47	-	-	
	RGL	150 000 47	150 000 44	150 000 44	150 000 44	150 000 44	standard	
Pressure gauge	GL	110 000 79	110 000 79	110 000 79	110 000 79	-	-	
	RGL	110 008 82	110 008 82	110 008 82	110 008 82	110 008 82	110 008 82	
Vacuum gauge	GL/RGL	110 005 69	110 005 69	110 005 69	110 005 69	110 005 69	110 005 69	
Combustion head extension	G5-G10	4" (100mm)	150 003 09	150 003 11	150 007 60	150 002 44	150 002 44	-
	G5-G11	8" (200mm)	150 001 09	150 001 10	150 007 61	150 002 45	150 002 45	190 000 14
	G5-G11	12" (300mm)	150 002 38	150 001 11	150 007 62	150 001 27	150 001 27	190 000 15
	GL5-GL9	4" (100mm)	150 003 10	150 003 12	150 007 68	150 002 50	-	-
	GL5-GL9	8" (200mm)	150 001 14	150 001 15	150 007 69	150 002 51	-	-
	GL5-GL9	12" (300mm)	150 002 39	150 001 16	150 007 70	150 001 28	-	-
	GL8T-GL9T	4" (100mm)	-	-	150 007 76	150 006 97	-	-
	GL8T-GL9T	8" (200mm)	-	-	150 007 77	150 006 89	-	-
	GL8T-GL9T	12" (300mm)	-	-	150 007 78	150 006 90	-	-
	RGL5-RGL10	4" (100mm)	150 006 32	150 006 35	150 007 84	150 002 56	150 002 56	-
	RGL5-RGL11	8" (200mm)	150 006 33	150 006 36	150 007 85	150 002 57	150 002 57	190 000 16
	RGL5-RGL11	12" (300mm)	150 006 34	150 006 37	150 007 86	150 001 29	150 001 29	190 000 17
Integral Switchgear (ISG) Gas burners only. "G" version ZD or ZMD		150 006 54	150 006 56	150 007 37	-	-	-	
Magnetic Clutch for dual fuel burner model GL (standard for RGL)		150 002 74	150 001 84	150 001 84	standard	standard	standard	
Flame sensor (UV scanner) instead of flame rod		150 002 29	150 002 29	150 002 29	150 002 29	150 002 29	150 002 29	
Potentiometer fitted to the servomotor (SQM) version ZMD	220 Ohm	110 002 86	110 002 86	110 002 86	110 002 86	110 002 86	110 002 86	
	1000 Ohm	110 003 03	110 003 03	110 003 03	110 003 03	110 003 03	110 003 03	
Solenoid for continuous motor run/post purge		150 010 07	150 010 07	150 010 07	150 010 07	150 010 07	150 010 07	

Technical Data

– weishaupt –

Description				G5 GL5 RGL5	G7 GL7 RGL7	G8 GL8 RGL8	G9 GL9 RGL9	G10 RGL10	G11 RGL11
Burner motor 3 phase	Model			D90/90-2	D112/110-2/1	D112/140-2/1	D132/120-2a	D132/120-2	D132/150-2
Capacity	KW			1.6	3.7	5.5	7.5	9.5	13.0
Capacity	HP			2.1	4.8	7.2	10	12.7	17.4
FLA burner motor 3 phase 460 V	A			3.4	6.3	9.5	13.0	17.0	25.0
Speed 60HZ	RPM			3360	3500	3500	3480	3450	3450
Ignition device	Model			W-ZG02/1	W-ZG02/1	W-ZG02/1	W-ZG02/1	W-ZG02/1	W-ZG02/1
Standard flame monitoring system (Landis & Staefa)				LFL 1.335	LFL 1.335	LFL 1.335	LFL 1.335	LFL 1.335	LFL 1.335
Servomotor model									
– High/low operation model G or GL version	ZD	Model (8 sec)		1055/80	1055/80	1055/80	–	–	–
– Combination gas/oil models GL version	ZMD	Model SQM (20 sec)		10.15561	10.15561	10.15561	10.15561	10.15561	10.15561
	TMD	Model SQM (20 sec)		10.15561	10.15561	10.15561	10.15561	10.15561	10.15561
– Modulating gas model G or									
– Combination gas/oil model RGL version	ZMD	Model SQM (42 sec)		10.16561	10.16561	10.16561	10.16561	10.16561	10.16561
Model of oil pump fitted as standard	GL			J6	J6	J6	J6/ J7/ TA2 ^①	–	–
	RGL			J6	TA2	TA3	TA3	TA3	TA4
Oil solenoid valves	110 V	1/4"	GL	Model	121K6220	121K6220	121K6220	121K6220	–
	110 V	1/8"		Model	121C2323	121K2423	121K2423	121K2423	–
	55 V	1/4"	RGL	Model	121K6220	121K6220	–	–	–
	55 V	1/8"		Model	121K2423	121K2423	–	–	–
	55 V	3/8"	Supply	Model	–	–	321H2322	321H2322	321H2322
	55 V	3/8"	Return	Model	–	–	121G2320	121G2320	121G2320
	110 V	1/8"		Model	–	–	121K2423	121K2423	121K2423
	110 V	1/8"		Model	–	–	122K9321	122K9321	122K9321
Oil hoses ID/length	GL	inches		1/2 /39.0	1/2 /39.0	1/2 /39.0	1/2 /39.0	–	–
		mm		13/1000	13/1000	13/1000	13/1000	–	–
	RGL	inches		1/2 /39.0	3/4 /39.0	3/4 /39.0	3/4 /39.0	3/4 /39.0	1.0/51.0
		mm		13/1000	20/1000	20/1000	20/1000	20/1000	25/1300
Weight									
Gas burners without gas train		lbs/kg		121/55	167/76	187/187	286/130	288/131	345/157
Combination gas/oil burners without gas train		lbs/kg		121/55	180/82	200/91	299/136	301/137	367/167

① Capacity of J6 pump: up to 58 USG/hr (200 kg/hr), over 58 USG/hr (200 kg/hr) up to 72 USG/hr (250 kg/hr) use J7 pump. Over 72 USG/hr (250 kg/hr) use TA2 pump (optional)

Dimensions

Weishaupt Corporation
 6280 Danville Road
 Mississauga, Ontario L5T 2H7
 Tel (905) 564 0946
 Fax (905) 564 0949
 www.weishaupt-corp.com
 Print No. 83000916, June 2004
 Printed in Germany. All rights reserved.

– weishaupt –

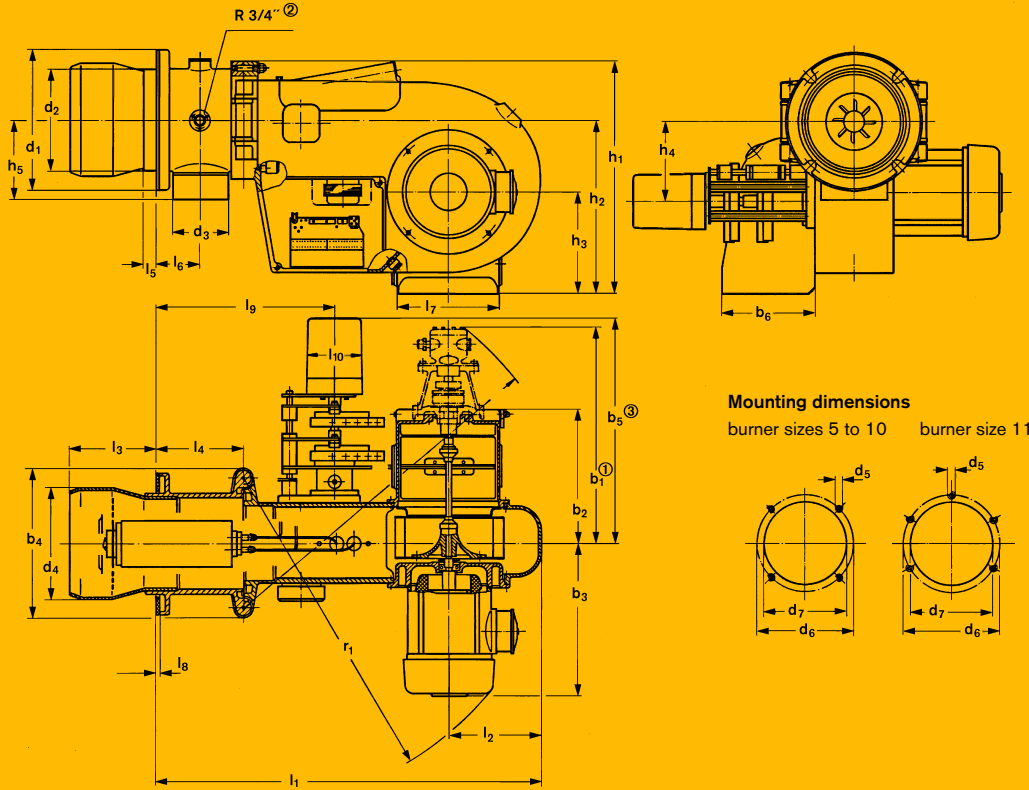

Mounting dimensions
 burner sizes 5 to 10 burner size 11

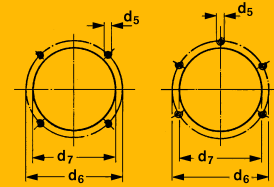

Size	Dimensions in inches (mm in brackets)															
	l1	l2	l3	l4	l5	l6	l7	l8	l9 ^⑤	l9 ^⑥	l10 ^⑤	l10 ^⑥	b1 ^①	b2	b3	b4
5	34 3/16 (868)	7 7/8 (200)	7 7/8 (200)	8 3/16 (208)	1 21/32 (42)	4 1/4 (108)	9 3/8 (238)	5/16 (8)	16 9/16 (421)	17 3/4 (451)	4 5/16 (110)	4 5/7 (120)	18 7/16 (468)	10 15/16 (278)	12 7/32 (310)	12 9/32 (312)
7	37 31/32 (965)	8 27/32 (225)	9 1/16 (230)	8 31/32 (228)	2 1/32 (52)	4 21/32 (118)	9 7/8 (251)	5/16 (8)	19 1/16 (484)	20 7/32 (514)	4 5/16 (110)	4 5/7 (120)	20 9/16 (522)	12 27/32 (326)	12 31/32 (330)	13 31/32 (355)
8	37 31/32 (965)	8 27/32 (225)	9 1/16 (230)	8 31/32 (228)	2 1/32 (52)	4 21/32 (118)	9 7/8 (251)	5/16 (8)	19 1/16 (484)	20 7/32 (514)	4 5/16 (110)	4 5/7 (120)	20 9/16 (522)	12 27/32 (326)	14 9/16 (370)	13 31/32 (355)
9	45 19/32 (1158)	11 13/16 (300)	9 3/16 (233)	9 3/4 (248)	2 7/16 (62)	5 1/32 (128)	15 13/32 (391)	5/16 (8)	-	20 19/32 (523)	-	4 5/7 (120)	22 (560)	14 1/16 (357)	16 3/4 (425)	19 7/32 (490)
10	45 19/32 (1158)	11 13/16 (300)	9 3/16 (233)	9 3/4 (248)	2 7/16 (62)	5 1/32 (128)	15 13/32 (391)	5/16 (8)	-	20 19/32 (523)	-	4 5/7 (120)	22 (560)	14 1/16 (357)	16 3/4 (425)	19 7/32 (490)
11	47 5/32 (1198)	11 13/16 (300)	10 21/32 (271)	11 11/32 (288)	3 7/32 (82)	5 13/16 (148)	15 13/32 (391)	5/16 (8)	-	22 5/32 (563)	-	4 5/7 (120)	22 7/32 (564)	14 1/16 (357)	17 7/8 (454)	19 7/32 (490)
Size	b5 ^③	b6	h1	h2	h3	h4	h5	d1	d2	d3	d4	d5 ^②	d6	d7	r1	r2 ^①
5	18 5/16 (465)	7 7/8 (200)	19 7/16 (494)	14 11/16 (373)	8 21/32 (220)	7 11/16 (195)	6 3/8 (162)	10 1/4 (260)	7 11/16 (195)	DN 50	7 7/8 (200)	M10 (9/8")	9 1/4 (235)	8 1/4 (210)	26 25/32 (680)	31 1/2 (800)
5/2	18 5/16 (465)	7 7/8 (200)	19 7/16 (494)	14 11/16 (373)	8 21/32 (220)	7 11/16 (195)	6 3/8 (162)	10 1/4 (260)	7 11/16 (195)	DN 50	8 15/32 (215)	M10 (9/8")	9 1/4 (235)	8 21/32 (220)	26 25/32 (680)	31 1/2 (800)
7	19 3/32 (485)	9 (229)	22 1/32 (560)	16 11/32 (415)	9 21/32 (245)	7 11/16 (195)	7 5/8 (182)	13 (330)	9 1/4 (235)	DN 65	9 27/32 (250)	M12 (1/2")	11 23/32 (298)	10 5/8 (270)	28 11/32 (720)	33 1/16 (840)
8	19 3/32 (485)	9 (229)	22 1/32 (560)	16 11/32 (415)	9 21/32 (245)	7 11/16 (195)	7 5/8 (182)	13 (330)	9 1/4 (235)	DN 65	10 7/16 (265)	M12 (1/2")	11 23/32 (298)	10 5/8 (270)	29 1/8 (740)	33 1/16 (840)
9	20 9/32 (515)	9 (229)	26 9/16 (675)	18 31/32 (482)	10 1/4 (260)	7 7/8 (200)	8 11/32 (212)	14 31/32 (380)	11 13/16 (300)	DN 80	12 23/32 (325)	M12 (1/2")	13 (330)	12 (305)	37 13/16 (960)	41 15/16 (1065)
10	20 9/32 (515)	9 (229)	26 9/16 (675)	18 31/32 (482)	10 1/4 (260)	7 7/8 (200)	8 11/32 (212)	14 31/32 (380)	11 13/16 (300)	DN 80	12 23/32 (325)	M12 (1/2")	13 (330)	12 (305)	37 13/16 (960)	41 15/16 (1065)
11	20 9/32 (515)	9 (229)	26 9/16 (675)	18 31/32 (482)	10 1/4 (260)	7 7/8 (200)	10 23/32 (272)	17 23/32 (450)	13 3/8 (340)	DN 100	14 31/32 (380)	M12 (1/2")	15 3/4 (400)	15 5/32 (385)	38 31/32 (990)	41 15/16 (1065)

Dimensions in inches are approximate. Weishaupt reserves the right to change the dimensions in the process of future developments

① With electromagnetic clutch (without electromagnetic clutch 4 1/2 inches (115mm) less)

② Pilot gas connection on both sides of burner sizes 8 – 11

③ Dimensions for burners version RGL (2 3/4 inches (70mm) less for burner models G and GL, in version ZM and 7 3/32 inches (180mm) less in version Z)

④ Flame tube of burner can only be removed with burner mounting plate

⑤ For sliding two stage burners version Z

⑥ For sliding two stage burners version ZM

* Adaption flange is delivered with burner. DN refers to inside diameter in mm.