

–weishaupt–

manual

Installation and operating instruction

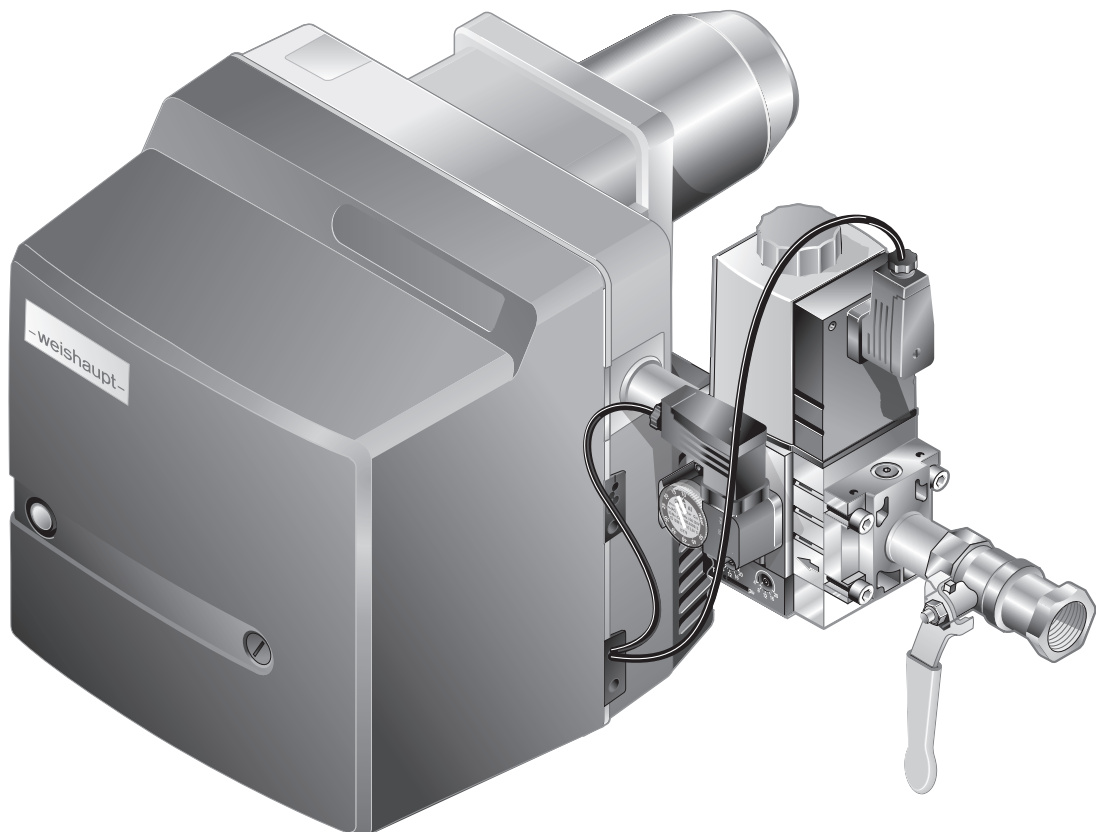

1	User instructions	5
1.1	Target group	5
1.2	Symbols	5
1.3	Guarantee and Liability	6
2	Safety	7
2.1	Designated application	7
2.2	When gas can be smelled	7
2.3	Safety measures	7
2.3.1	Personal protective equipment (PPE)	7
2.3.2	Normal operation	7
2.3.3	Electrical work	8
2.3.4	Gas supply	8
2.4	Alterations to the construction of the equipment	8
2.5	Noise emission	8
2.6	Disposal	8
3	Product description	9
3.1	Type key	9
3.2	Serial number	10
3.3	Function	11
3.3.1	Air supply	11
3.3.2	Gas supply	12
3.3.3	Electrical components	13
3.3.4	Program sequence	14
3.4	Technical data	16
3.4.1	Approval data	16
3.4.2	Electrical data	16
3.4.3	Ambient conditions	16
3.4.4	Fuels	16
3.4.5	Emissions	17
3.4.6	Rating	18
3.4.7	Dimensions	19
3.4.8	Weight	20
4	Installation	21
4.1	Installation conditions	21
4.2	Burner installation	22
5	Installation	23
5.1	Gas supply	23
5.1.1	Installing the gas valve train	24
5.1.2	Carry out soundness test of gas supply line and vent	26
5.2	Electrical connection	27
6	Operation	28
6.1	Operating panel	28
6.2	Display	28
7	Commissioning	29
7.1	Prerequisite	29

7.1.1	Connect measuring devices	30
7.1.2	Check gas connection pressure	31
7.1.3	Check soundness of gas valve train	32
7.1.4	Purging the gas valve train	35
7.1.5	Preset pressure regulator	36
7.1.6	Setting values	38
7.1.7	Preset gas and air pressure switch	41
7.2	Adjusting the burner	42
7.3	Set pressure switches	44
7.3.1	Set gas pressure switch	44
7.3.2	Set air pressure switch	45
7.4	Concluding work	46
7.5	Check combustion	47
7.6	Calculate gas throughput	48
8	Shutdown	49
9	Servicing	50
9.1	Notes on servicing	50
9.2	Service plan	51
9.3	Removing and refitting mixing head	52
9.4	Set mixing head	53
9.5	Set ionisation and ignition electrodes	54
9.6	Service position	55
9.7	Removing and refitting fan wheel	56
9.8	Remove burner motor	56
9.9	Removing and refitting manual adjustment of air damper	57
9.10	Removing and refitting angle drive	58
9.11	Removing and refitting gas butterfly valve	59
9.12	Removing and refitting air regulator	60
9.13	Replacing coil on multifunction assembly	61
9.14	Replace breather plug of multifunction assembly	61
9.15	Removing and refitting filter insert of multifunction assembly	62
9.16	Replacing the fuse	63
10	Troubleshooting	64
10.1	Procedures for fault conditions	64
10.1.1	Illuminated push button off	64
10.1.2	Illuminated push button red	65
10.1.3	Illuminated push button flashes	68
10.2	Operating problems	69
11	Technical documentation	70
11.1	Wiring diagram	70
11.2	Conversion table unit of pressure	72
11.3	Appliance categories	73
12	Project planning	77
12.1	Continuous running fan or post-purge	77

13	Spares	78
14	Notes	88
15	Key word index	90

1 User instructions

Translation of original
operating instructions

This manual forms part of the equipment and must be kept on site.
Carefully read the manual prior to working on the unit.

1.1 Target group







The manual is intended for the operator and qualified personnel. It should be observed by all personnel working with the unit.

Work on the unit must only be carried out by personnel who have the relevant training and instruction.

Persons with limited physical, sensory or mental capabilities may only work on the unit if they are supervised or have been trained by an authorised person.

Children must not play with the unit.

1.2 Symbols

 DANGER	Immediate danger with high risk. Non observance can lead to serious injury or death.
 WARNING	Danger with medium risk. Non observance can lead to environmental damage, serious injury or death.
 CAUTION	Danger with low risk. Non observance can cause damage to the equipment and injury to personnel.
	Important information
	Requires direct action
	Result after an action
	Itemisation
...	Range of values

1 User instructions

1.3 Guarantee and Liability

Guarantee and liability claims for personal and equipment damage are excluded, if they can be attributed to one or more of the following causes:

- non approved application,
- non-observance of the manual,
- operation with faulty safety equipment,
- continual operation despite a fault,
- improper installation, commissioning, operation and service,
- repairs, which have been carried out incorrectly,
- the use of non original Weishaupt parts,
- force majeure,
- unauthorised modifications made to the unit,
- the installation of additional components, which have not been tested with the unit,
- the installation of combustion chamber inserts, which impede full flame formation,
- unsuitable fuels,
- defects in the inlet lines.

2 Safety

2.1 Designated application

The burner is suitable for operation on heat exchangers to EN 303 and EN 676.

If the burner is not used on combustion chambers to EN 303 and EN 676, a safety assessment of combustion and flame stability during individual process conditions and of the shutdown limits of the combustion plant has to be carried out and documented.

The combustion air must be free from aggressive compounds (e.g. Halogens). If the combustion air in the boiler room is contaminated, increased cleaning and servicing will be required. In this case ducted air intake is recommended.

The burner should only be used in enclosed rooms.

Improper use could:

- endanger the health and safety of the user or third parties,
- cause damage to the unit or other material assets.

2.2 When gas can be smelled

Avoid open flames and spark generation, for example:

- do not operate light switches,
- do not operate electronic equipment,
- do not use mobile telephones.
- ▶ Open doors and windows.
- ▶ Close gas isolating valve.
- ▶ Warn the inhabitants, do not ring door bells.
- ▶ Leave the building.
- ▶ Inform the heating contractor or gas supplier from outside of the building.

2.3 Safety measures

Safety relevant fault conditions must be eliminated immediately.

Components, which show increased wear and tear or whose design lifespan is or will be exceeded prior to the next service should be replaced as a precaution.

The design lifespan of the components is listed in the service plan [ch. 9.2].

2.3.1 Personal protective equipment (PPE)

Use the necessary personal protective equipment for all work.

2.3.2 Normal operation

- All labels on the unit must be kept in a legible condition.
- Stipulated settings, service and inspection work should be carried out at regular intervals.
- Only operate the unit with its cover closed.

2 Safety

2.3.3 Electrical work

For work carried out on live components:

- Observe the accident prevention instructions DGUV Regulation 3 and adhere to local directives,
- tools in accordance with EN 60900 should be used.

The device contains components, which could be damaged by electrostatic discharge (ESD).

When working on circuit boards and contacts:

- do not touch circuit boards or contacts,
- if necessary, take ESD protective measures.

2.3.4 Gas supply

- Only the gas supply company or an approved agent may carry out installation, alteration and maintenance work on gas appliances in buildings and properties.
- Pipework must be subject to a combined load and valve proving test and/or usability testing relative to the pressure range intended, e. g. DVGW-TRGI, worksheet G 600.
- Inform the gas supply company about the type and size of plant prior to installation.
- Local regulations and guidelines must be observed during installation, e. g. DVGW-TRGI, worksheet G 600; TRF Band 1 and Band 2.
- The gas supply pipework should be suitable for the type and quality of gas and should be designed in such a way that it is not possible for liquids to form, e. g. condensate. Observe vaporisation pressure and vaporisation temperature of liquid petroleum gas.
- Use only tested and approved sealing materials, whilst observing all process information.
- Re-commission the appliance when changing to a different type of gas. Changing from LPG to Natural Gas and visa versa requires a conversion.
- Carry out soundness test after each service and fault rectification.

2.4 Alterations to the construction of the equipment

All conversions require written approval from Max Weishaupt GmbH.

- No additional components may be fitted, which have not been tested for use with the equipment.
- Do not use combustion chamber inserts, which hinder flame burnout.
- Use only original Weishaupt replacement parts.

2.5 Noise emission

The noise emissions are determined by the acoustic behaviour of all components fitted to the combustion system.

Prolonged exposure to high noise levels can lead to loss of hearing. Provide operating personnel with protective equipment.

Noise emissions can further be reduced with a sound attenuator.

2.6 Disposal

Dispose of all materials and components in a safe and environmentally friendly way at an authorised location. Observe local regulations.

3 Product description

3.1 Type key

Example: WG10N/-1D LN

Type

W	Series: Compact burner
G	Fuel: Gas
10	Size
N	N: Natural Gas F: Liquid Petroleum Gas
1	Ratings size
D	Construction

Version

LN	Mixing head: LowNO _x
----	---------------------------------

3 Product description

3.2 Serial number

The serial number on the name plate identifies the product. This is required by Weishaupt's customer service department.

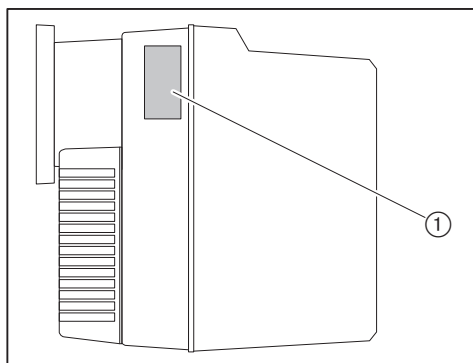

① Name plate

Ser.No. _____

3.3 Function

3.3.1 Air supply

Air damper

The air damper regulates the air quantity required for combustion. The air damper position is set using a setting screw on the air damper .

Fan wheel

The fan wheel supplies the air from the air intake housing to the combustion head.

Diffuser

The air gap between flame tube and diffuser is adjusted by positioning the diffuser. This adjusts the mixing pressure and the air quantity required for combustion.

Air pressure switch

The air pressure switch monitors the fan pressure. If the fan pressure is insufficient, the combustion manager initiates a lockout.

3 Product description

3.3.2 Gas supply

Gas isolating valve ①

The gas isolating valve opens and shuts off the gas supply.

Multifunction assembly ⑧

The multifunction assembly contains:

Gas filter ②	The gas filter protects the subsequent valve train components from foreign particles.
Double gas valve ④	The double gas valve opens and shuts off the gas supply.
Pressure regulator ③	The pressure regulator reduces the connection pressure and ensures a constant setting pressure.

Gas butterfly valve ⑤

The gas butterfly valve regulates the gas quantity depending on the rating required. The air/gas ratio is adapted via mechanical compound to the air damper setting.

Low gas pressure switch ⑦

If the gas connection pressure is lower than the value set, the low gas pressure switch initiates a low gas programme at the combustion manager.

In the low gas programme the combustion manager interrupts burner start and burner operation. Following a low gas waiting time of 10 minutes an automatic re-start is initiated.

High gas pressure switch ⑥ (optional)

The high gas pressure switch monitors the setting pressure. If the setting pressure exceeds the value set, the combustion manager initiates a controlled shutdown.

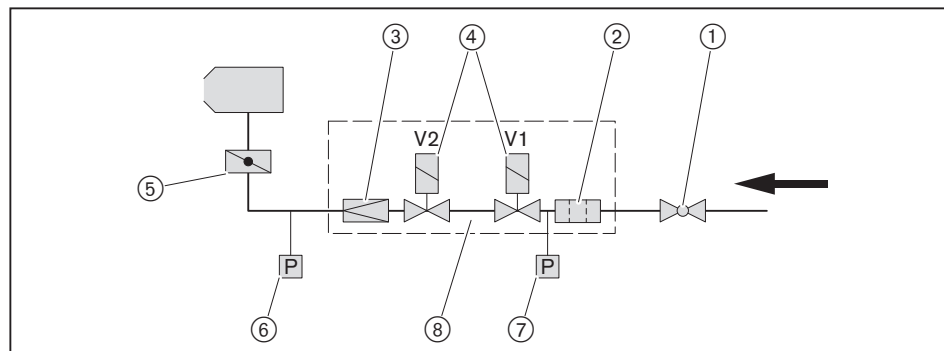

3.3.3 Electrical components

Combustion Manager

The combustion manager W-FM is the control unit of the burner. It controls the sequence of operation and monitors the flame.

Burner motor

The burner motor drives the fan wheel.

Ignition unit

The electronic ignition unit creates a spark at the electrode, which ignites the fuel/air mixture.

Ionisation electrode

The combustion manager monitors the flame signal via the ionisation electrode. If the flame signal becomes too weak, the combustion manager carries out a controlled shutdown.

3 Product description

3.3.4 Program sequence

Pre-purge

At heat demand, the burner motor starts after the initialisation time (T_i) has elapsed and the gas pressure switch has been activated.

The air pressure switch is activated during the pre-purge phase (T_v).

Ignition

Pre-ignition time (T_{vz}) starts before the end of the pre-purge time (T_v).

Ignition starts.

Fuel release

Following pre-ignition time (T_{vz}) the double gas valve (K32) opens and releases the fuel.

Safety time

With fuel release, safety time (T_s) and post-ignition time (T_{Nz}) start.

The flame signal must be present within the safety time (T_s).

Operation

The combustion manager monitors the flame signal via the ionisation electrode.

Post-purge

If there is no longer a heat demand, the double gas valve (K32) closes and stops the fuel supply.

Post-purge time (T_N) begins.

Following the post-purge time (T_N) the burner motor switches off.

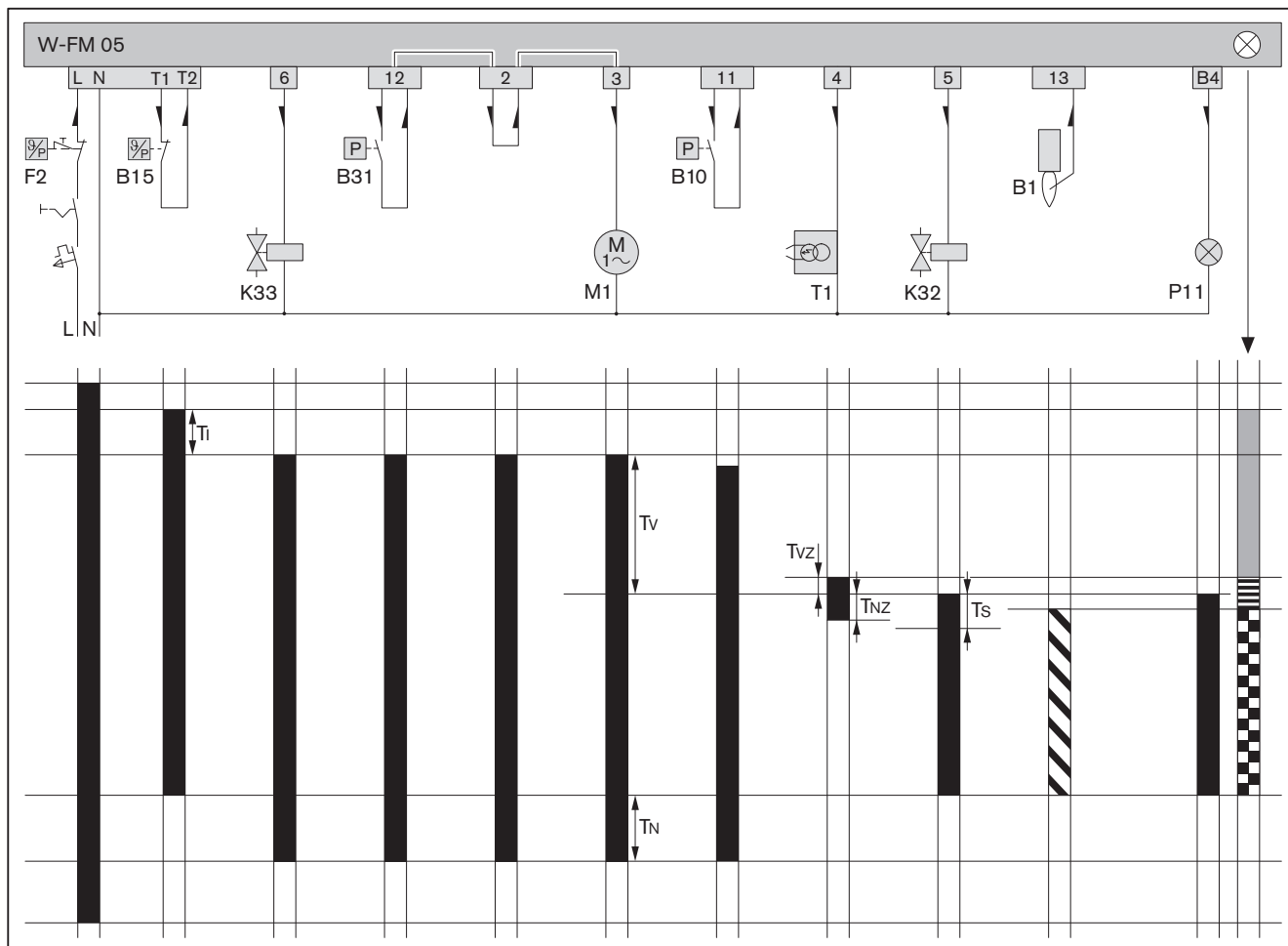

- B1 Ionisation electrode
- B10 Air pressure switch
- B15 Temperature or pressure regulator
- B31 Low gas pressure switch
- F2 Temperature or pressure limiter
- K32 Double gas valve
- K33 External valve LPG
- M1 Burner motor
- P11 Control lamp operation (optional)
- T1 Ignition unit

- T_i Initialisation time: 1 s
- T_N Post-purge time: 1.2 s
- T_{NZ} Post-purge time: 2.4 s
- T_v Pre-purge time: 21.5 s
- T_s Safety time: 2.7 s
- T_{vZ} Pre-ignition time: 1.9 s
- Voltage is applied
- ▨ Flame signal present
- Current path
- Start (orange)
- ▨ Ignition phase (flashing orange)
- ▣ Burner operation (green)

3 Product description

3.4 Technical data

3.4.1 Approval data

PIN (EU) 2016/426	CE-0085BM0481
Basic standards	EN 676:2008 Additional standards, see EU conformity certification.

3.4.2 Electrical data

Mains voltage / mains frequency	230 V/50 Hz
Consumption at start	max 241 W
Consumption during operation	max 141 W
Power consumption	max 1.1 A
Internal unit fuse	T6.3H, IEC 127-2/5
External fuse	max 16 AB

3.4.3 Ambient conditions

Temperature in operation	–15 ... +40 °C
Temperature during transport / storage	–20 ... +70 °C
relative humidity	max 80 %, no dew point
Installation elevation	max 2000 m ⁽¹⁾

⁽¹⁾ Consultation with Weishaupt is required for higher installation elevation.

3.4.4 Fuels

- Natural Gas E/LL
- Liquid Petroleum Gas B/P

3.4.5 Emissions

Flue gas

To EN 676 the burner complies with emission class 3.

The NO_x values are influenced by:

- combustion chamber dimensions
- flue gas system
- fuel
- combustion air (temperature and humidity)
- medium temperature

Combustion chamber dimensions, see Weishaupt Partner Portal / Documents and Applications / Online Applications / NO_x calculation for burners.

Sound levels

Dual number noise emission values

Measured sound power level L _{WA} (re 1 pW)	69 dB(A) ⁽¹⁾
Uncertainty value K _{WA}	4 dB(A)
Measured sound pressure level L _{pA} (re 20 µPa)	65 dB(A) ⁽²⁾
Uncertainty value K _{pA}	4 dB(A)

⁽¹⁾ Determined to ISO 9614-2.

⁽²⁾ Determined at 1 metre distance from the front of the burner.

The measured noise levels plus uncertainty values form the upper limit value, which could occur when measuring.

3 Product description

3.4.6 Rating

Combustion heat rating

Natural Gas	40 ... 110 kW
Liquid Petroleum Gas	40 ... 110 kW
Combustion head	WG10-D

Capacity graph

Capacity graph to EN 676.

The capacity data given relates to an installation elevation of 0 m above sea level. For installation elevations above 0 m a capacity reduction of approx. 1 % per 100 m applies.

A limited capacity graph is valid for ducted air intake.

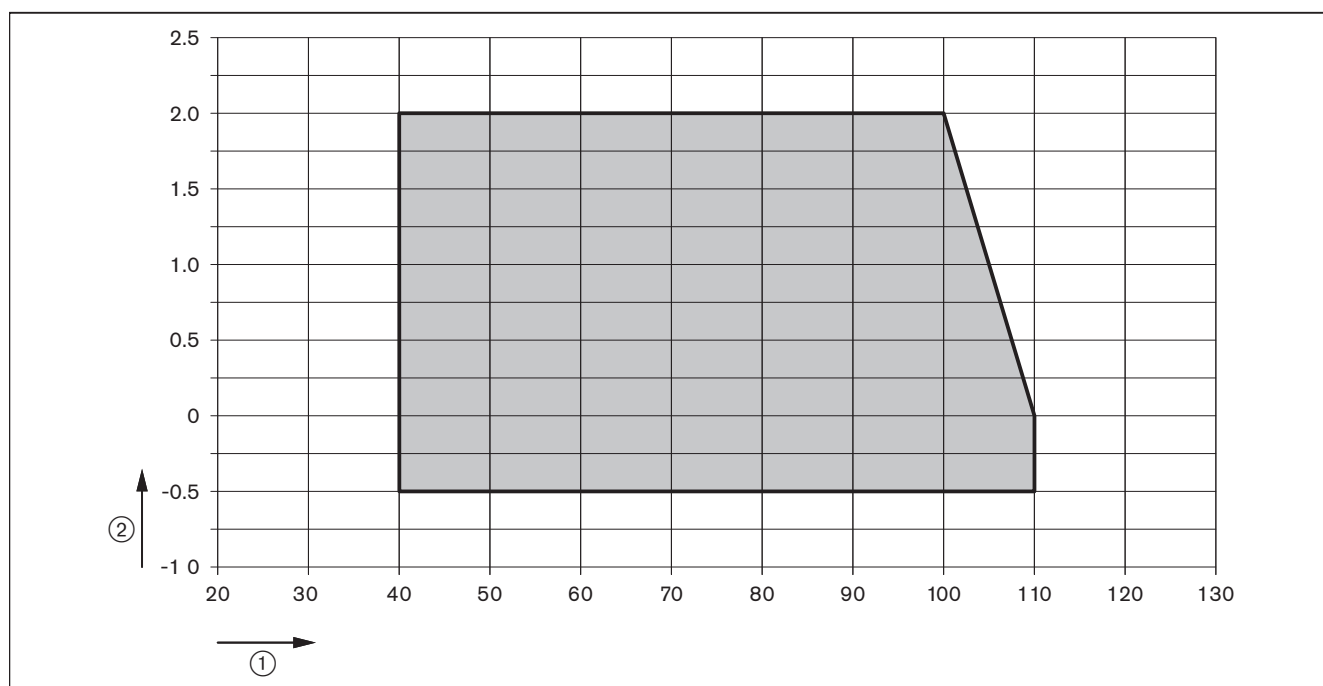

- ① Combustion heat rating [kW]
- ② Combustion chamber pressure [mbar]

3.4.7 Dimensions

Burner

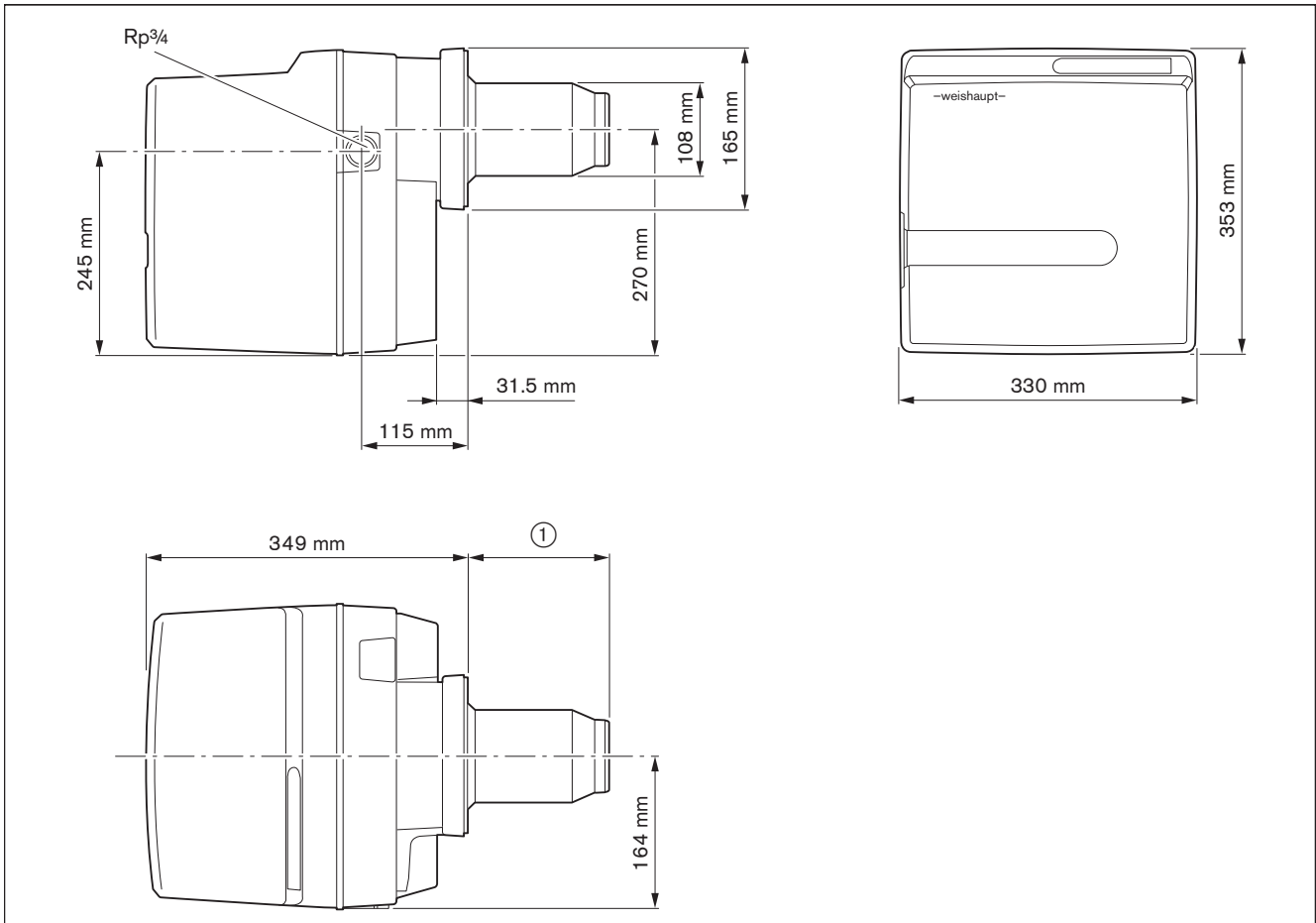

- ① 140 mm without combustion head extension
- 240 mm with combustion head extension (100 mm)
- 340 mm with combustion head extension (200 mm)
- 440 mm with combustion head extension (300 mm)

3 Product description

Gas valve train

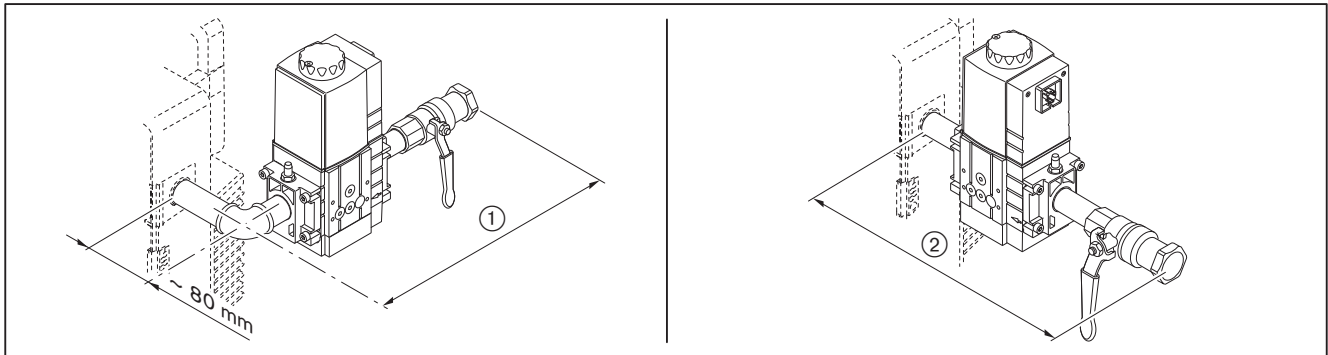

	Isolating valve	With thermal shut off device	Without thermal shut off device
①	Rp ^{3/4} Rp1	approx. 310 mm approx. 320 mm	approx. 295 mm approx. 300 mm
②	Rp ^{3/4} Rp1	approx. 310 mm approx. 320 mm	approx. 295 mm approx. 300 mm

3.4.8 Weight

approx. 14 kg

4 Installation

4.1 Installation conditions

Burner type and capacity graph

Burner and heat exchanger must be matched.

- ▶ Check burner type and burner capacity.

Installation location

- ▶ Prior to installation ensure that:
 - sufficient space is available for normal and service position [ch. 3.4.7],
 - sufficient combustion air is available, if necessary install ducted air intake,

Prepare heat exchanger

The refractory ③ must not protrude beyond the front edge of the combustion head. The refractory can take a conical shape (min 60°).

Refractory may not be required on boilers with water-cooled front, unless the manufacturer gives other instructions.

Following installation, the aperture ④ between flame tube and refractory should be filled with flame-proof, resilient insulating material. Do not make solid.

Heat exchangers with deep refractories or thick doors, or heat exchangers with reverse flame combustion chambers may require a combustion head extension. Head extensions of 100, 200 and 300 mm are available. Dimension ② then changes according to the head extension used.

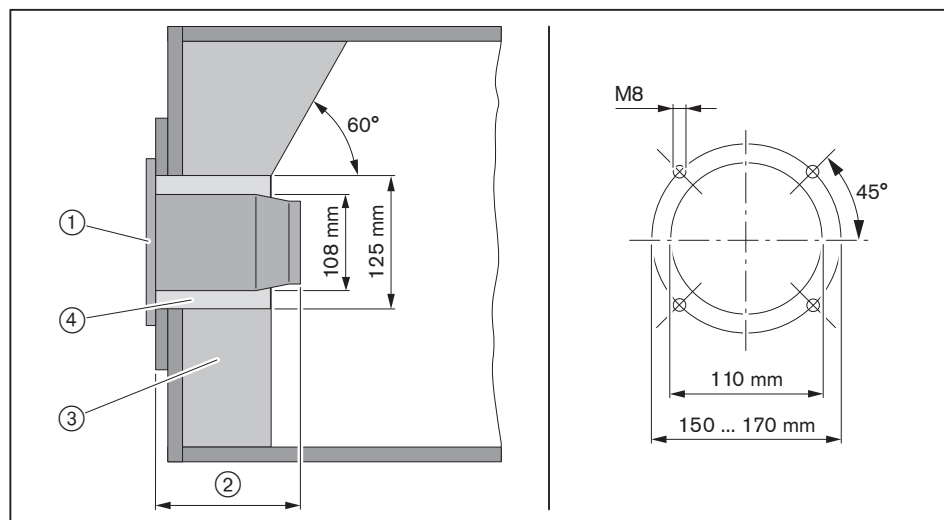

- ① Flange gasket
- ② 140 mm
- ③ Refractory
- ④ Aperture

4 Installation

4.2 Burner installation



Only valid in Switzerland

When installing and operating the regulations of SVGW, VKF, local and Cantonal regulations and the EKAS guideline (LPG Guideline Part 2) must be observed.



The burner in its standard version is designed for valve train connection from the right. For gas valve train connection from the left the burner has to be installed rotated by 180°. This requires conversion measures [ch. 5.1.1].

- ▶ Remove mixing head [ch. 9.3].
- ▶ Remove burner flange ① from burner housing.
- ▶ Fit flange gasket ② and burner flange ① to the heat exchanger using screws ③.
- ▶ The aperture between combustion head and refractory should be filled with flame-proof, resilient insulating material (do not make solid).

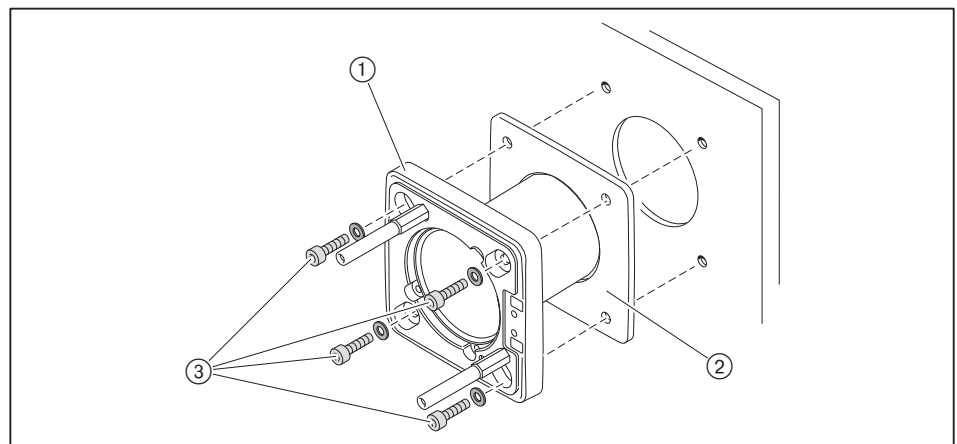

- ▶ Mount burner with screws ① to burner flange.

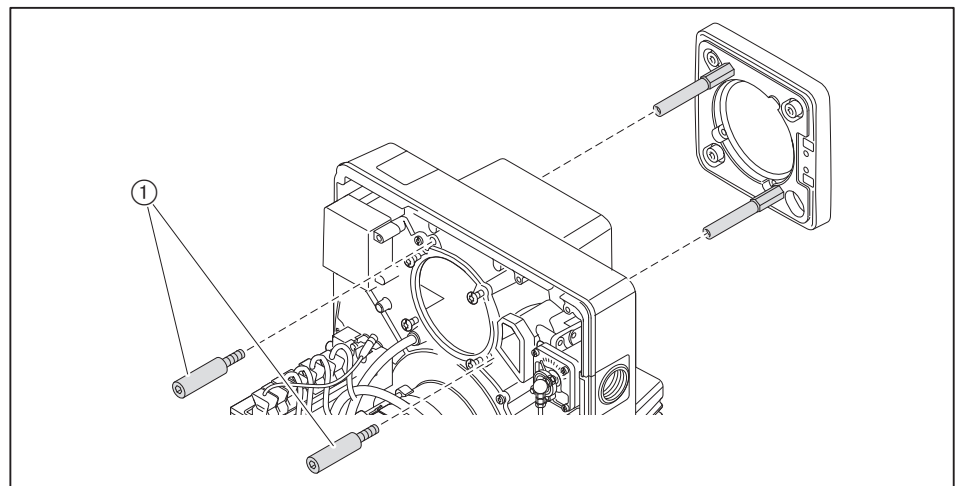

- ▶ Check setting of electrodes [ch. 9.5].
- ▶ Fit mixing head [ch. 9.3].

5 Installation

5.1 Gas supply



Risk of explosion due to leaking gas

Gas leaks can lead to a build-up of explosive gas/air mixture. With an ignition source present this can result in an explosion.

- ▶ Install gas supply with care.
- ▶ Observe all safety instructions.

Only an approved gas installer may carry out the gas side connection. Observe local regulations.

The following should be obtained from the gas supply company:

- Type of gas
- Gas connection pressure.
- Maximum CO₂ content in the flue gas.
- Calorific value in normal condition [kWh/m³].

Observe maximum permissible pressure of all components of the gas valve train.

- ▶ Close all fuel shut off devices prior to commencing work and protect from accidental re-opening.

General installation instructions

- Install manually operated shut off device (gas isolating valve) in the supply.
- Ensure correct mounting alignment and cleanliness of sealing surfaces.
- Mount valve train free of vibration. It must not be allowed to swing. Suitable supports should be fitted.
- Mount gas valve train free of stresses.
- The distance between burner and Multifunction assembly should be as small as possible. If the distance is too great, it is possible that a gas/air mixture is formed, which will influence burner start.
- Observe sequence and flow direction of gas valve train.
- If necessary, fit thermal shut off device (TAE) in front of the gas isolating valve.

Installation position

Multifunction assembly can be installed with the axis standing vertical to lying horizontal.

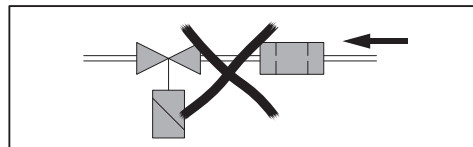

5 Installation

5.1.1 Installing the gas valve train



Only in conjunction with W-MF and gas connection pressure > 150 mbar

If the gas connection pressure is > 150 mbar, a pressure regulator has to be fitted upstream of the W-MF.

- ▶ Install the gas valve train, see additional sheet (Print No. 835109xx).

Installing the valve train from the right

- ▶ Remove protective foil from gas connection flange.
- ▶ Mount gas valve train free from stresses. Do not compensate for installation errors by over-tightening the flange screws.
- ▶ Ensure correct alignment of flange seals.
- ▶ Tighten screws evenly diagonally across.



No additional sealant is required if the thread is coated in blue.

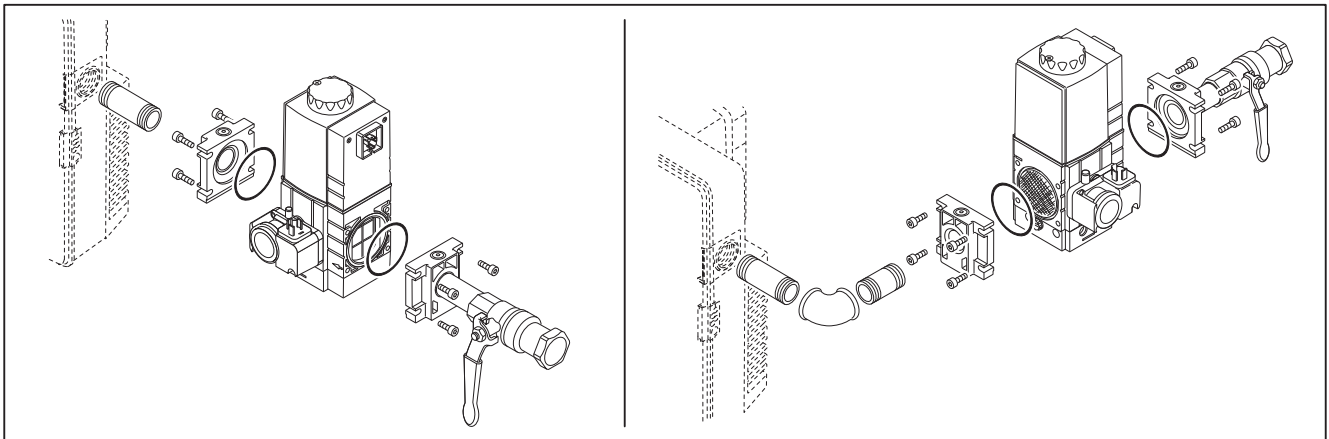

Installing the gas valve train from the left

To fit the gas valve train to the burner from the left, the burner has to be installed rotated by 180°. To do this, additional conversion measures are required.

Move the gas pressure switch prior to installing the multifunction assembly:

- ▶ Remove closing plug ① and gas pressure switch ③.
- ▶ Mount gas pressure switch ③ and O ring ② on the opposite side.
- ▶ Mount closing plug ① on the opposite side.

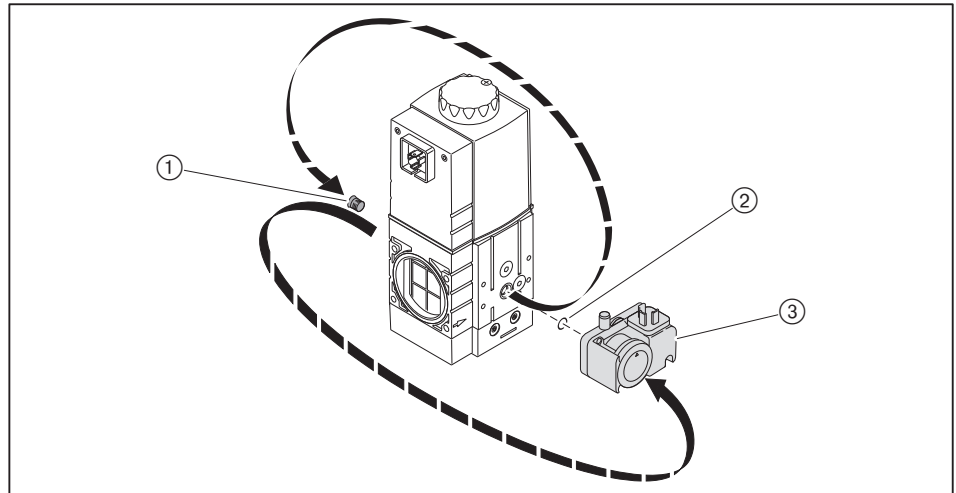

- ▶ Continue installation in the same way as for "Mount gas valve train from the right".

5 Installation

Accessories

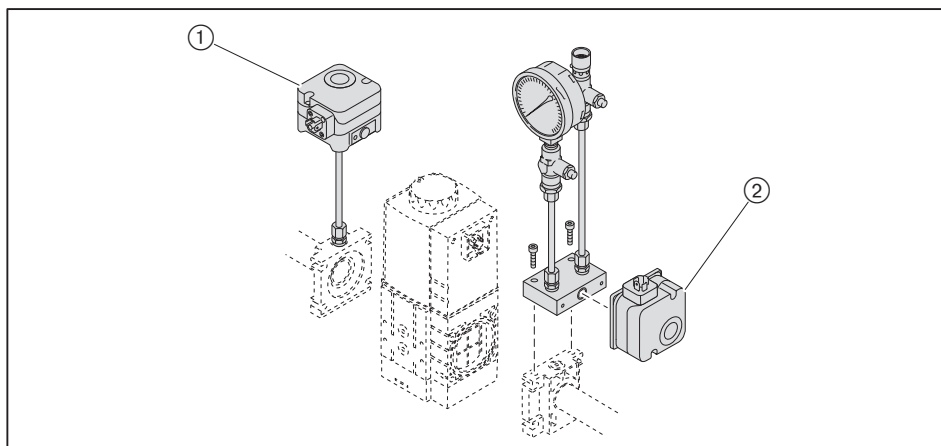

- ① High gas pressure switch with mechanical interlock (B33)
- ② Low gas pressure switch with mechanical interlock (B34)

5.1.2 Carry out soundness test of gas supply line and vent

Only the gas supply company or a contract installation company may carry out a soundness test and vent the gas line.

5.2 Electrical connection



Risk of electric shock

Working on the device when voltage is applied can lead to electric shock.

- ▶ Isolate the device from the power supply prior to starting any work.
- ▶ Safeguard against accidental restart.

The electrical connection must only be carried out by qualified electricians. Observe local regulations.

Observe wiring diagram [ch. 11.1].

- ▶ Plug in plug for gas pressure switch ② and double gas valve ③ and secure with screws.
- ▶ Check polarity and wiring of 7 pole connection plug ①.
- ▶ Plug in connection plug ①.

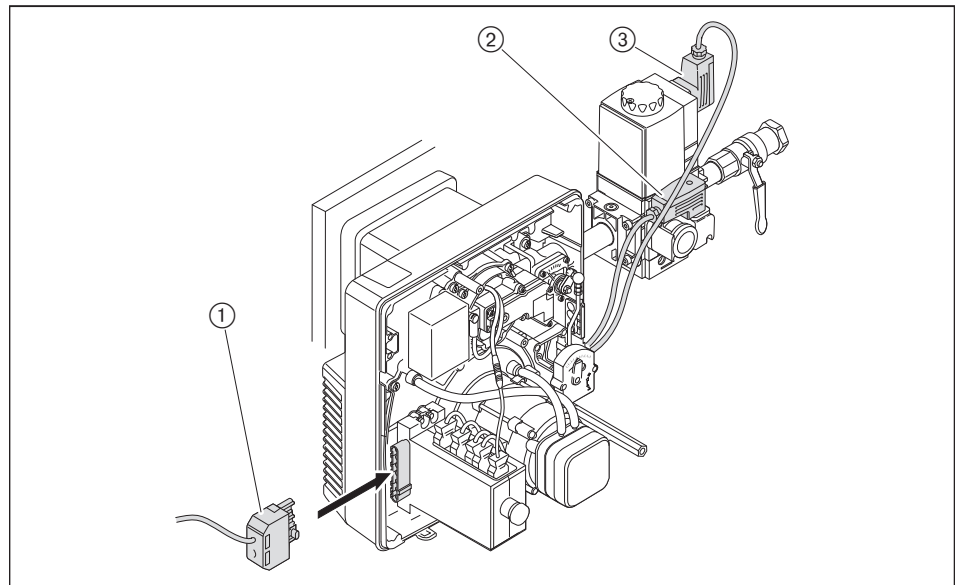

With remote reset, install connection line separately. Do not exceed maximum cable length of 10 metres.

6 Operation

6 Operation

6.1 Operating panel



Damage to the combustion manager due to incorrect operation

Excessive pressure applied to the illuminated push button can damage the combustion manager.

- ▶ Only lightly press illuminated push button.

The illuminated push button on the combustion manager has the following functions:

- display operating condition [ch. 6.2],
- display fault codes [ch. 10.1.2],
- reset burner lockout [ch. 10.1.2].

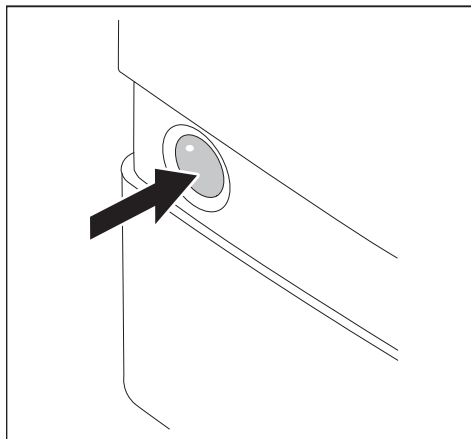

Re-starting the burner during burner operation:

- ▶ Press illuminated push button for 1 second.

6.2 Display

Illuminated push button	Operating condition
orange	Start phase
Flashing orange	Ignition and pre-purge phase
Green	Operation
red	Fault [ch. 10]

Additional flashing signals can be read off as fault code [ch. 10].

7 Commissioning

7.1 Prerequisite

Commissioning must only be carried out by qualified personnel.

Only correctly carried out commissioning ensures the operational safety.



Do not operate the burner outside of the capacity graph [ch. 3.4.6].

► Prior to commissioning ensure that:

- all assembly and installation work has been carried out correctly,
- sufficient combustion air is available, if necessary install ducted air intake
- the annulus between flame tube and heat exchanger is filled
- the heat exchanger is filled with medium
- the regulating, control and safety devices are functioning and set correctly
- the flue gas ducts are unimpeded
- a measuring point conforming to standards is available to measure the flue gas
- the heat exchanger and flue gas ducting up to the test point are sound (extraneous air influences the test results)
- the operating instructions of the heat exchanger are complied with
- a heat demand is available

Additional system-related tests could be necessary. Please observe the operating guidelines for the individual components.

On installations with process equipment, the conditions for safe operation and commissioning must be met, see worksheet 8-1 (Print No. 831880xx).

7 Commissioning

7.1.1 Connect measuring devices

Measuring device for ionisation current

- ▶ Remove ionisation cable from the plug coupling.
- ▶ Connect current measuring device in series.

Ionisation current

Extraneous light detection from	0.8 μ A
Minimum ionisation current	1.5 μ A
Recommended ionisation current	5 ... 20 μ A

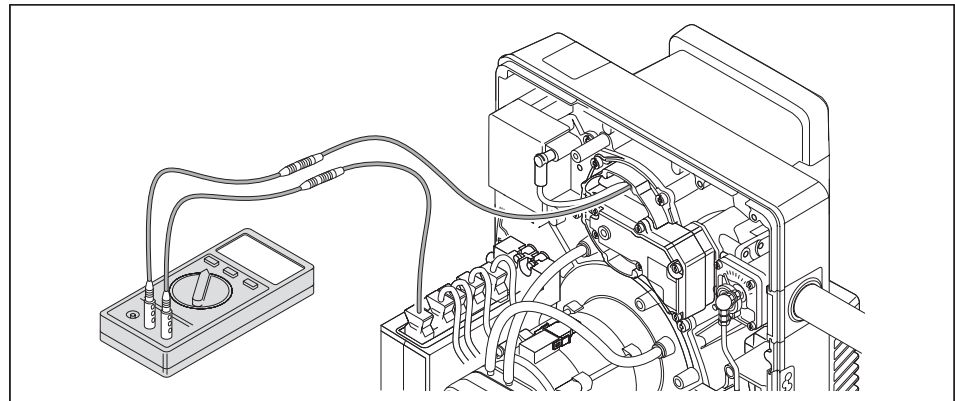

Pressure measuring device for mixing pressure

- ▶ Open pressure test point for mixing pressure ① and connect pressure measuring device.

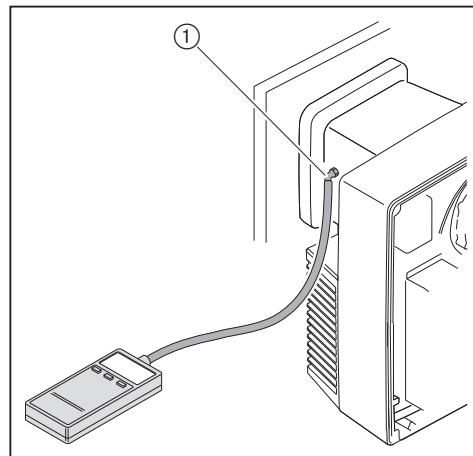

7.1.2 Check gas connection pressure

Minimum connection pressure



Add the combustion chamber pressure in mbar to the minimum connection pressure. The connection pressure should not fall below 15 mbar.

- ▶ Determine minimum connection pressure for low pressure installations from table [ch. 7.1.5].

Maximum connection pressure

Maximum connection pressure into isolating valve is 300 mbar.

Check connection pressure



Risk of explosion due to excess gas supply pressure

Exceeding the maximum connection pressure (see name plate) can damage the gas valve train and lead to an explosion.

Max. connection pressure see name plate.

- ▶ Check gas connection pressure



Only in conjunction with W-MF and gas connection pressure > 150 mbar

The pressure measuring device must be connected to the pressure regulator.

- ▶ Check gas connection pressure, see additional sheet (print No. 835109xx).

- ▶ Connect pressure measuring device to test point ①.
- ▶ Slowly open isolating valve whilst observing the pressure increase.

If the connection pressure exceeds the max. connection pressure:

- ▶ Immediately close isolating valve.
- ▶ Do not start plant.
- ▶ Notify system operator.

If the connection pressure does not maintain the min. connection pressure:

- ▶ Do not start plant.
- ▶ Notify system operator.

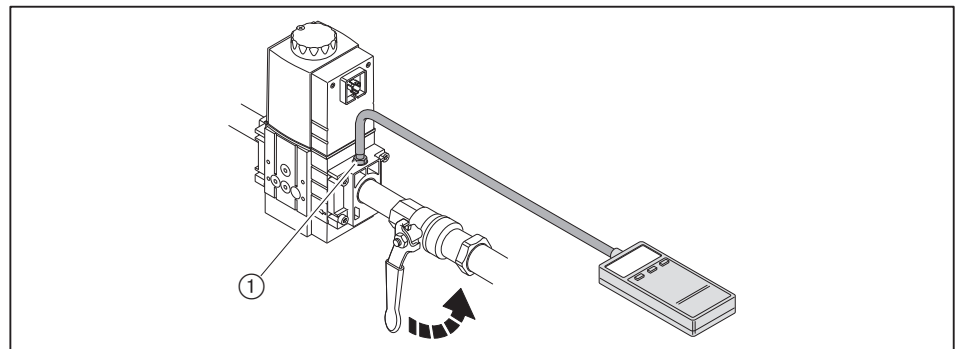

7 Commissioning

7.1.3 Check soundness of gas valve train

Carry out soundness test:

- prior to commissioning,
- after all service and maintenance work.

	First test phase	Second and third test phase
Test pressure	100 mbar ± 10 %	100 mbar ± 10 %
Waiting time for pressure equalisation	5 minutes	5 minutes
Test time	5 minutes	5 minutes
Permissible pressure loss	1 mbar	5 mbar

First test phase



Only in conjunction with W-MF and gas connection pressure > 150 mbar

In the first test phase, the testing device must be connected to the pressure regulator.

- ▶ Check soundness of gas valve train, see additional sheet (print No. 835109xx).

In the first phase the valve train section from the gas isolating valve up to the first valve of the multifunction assembly is tested.

- ▶ Switch off burner.
- ▶ Close gas isolating valve.
- ▶ Connect test equipment.
- ▶ Open test point between valve 1 and valve 2.
- ▶ Carry out test to table.

Second test phase

In the second phase the interspace in the multifunction assembly is tested.

- ▶ Connect test equipment.
- ▶ Carry out test to table.

Third test phase

In the third phase the valve train section from the multifunction assembly up to the gas butterfly valve is tested.

- ▶ Remove mixing head [ch. 9.3].
- ▶ Fit blanking plate ④.
- ▶ Fit mixing head.
- ▶ Connect test equipment.
- ▶ Carry out test to table.
- ▶ Close all test points.
- ▶ Remove blanking plate.

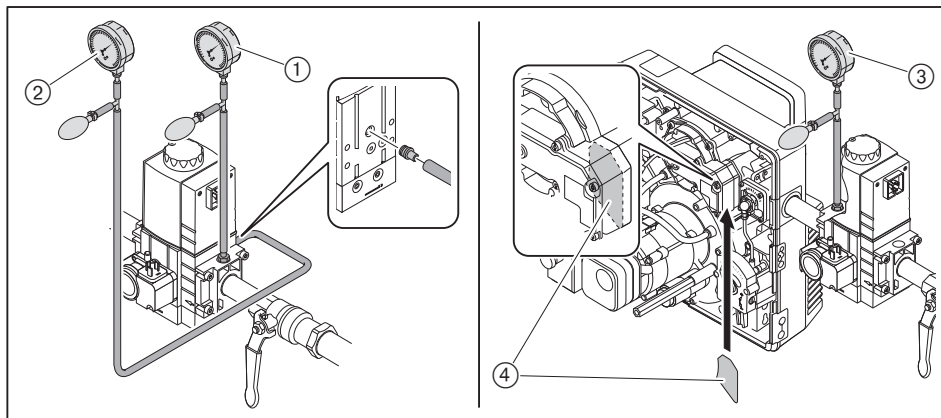

- ① First test phase
- ② Second test phase
- ③ Third test phase
- ④ Blanking plate

Fourth test phase

In the fourth test phase, the joint to the mixing head ① is tested for soundness. The test phase can only be carried out during or after burner commissioning. A leak detecting spray or electronic gas detector should be used for testing.

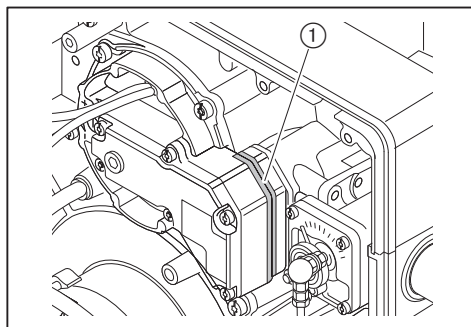

Use only leak detecting foam solutions, which do not cause corrosion, see DVGW-TRGI, worksheet G 600.

- ▶ Check all components, intersections and test points of the gas valve train between multifunction assembly and burner.
- ▶ Document result of the soundness test on the engineers report.

7 Commissioning

Test points

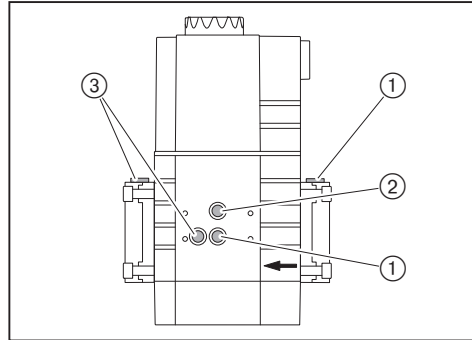

- ① Pressure into valve 1
- ② Pressure between valve 1 and valve 2
- ③ Pressure after valve 2

7.1.4 Purging the gas valve train

- ▶ Open test point into valve 1 [ch. 7.1.3].
- ▶ Connect an approved vent hose to the test point.
- ▶ Vent hose must lead to atmosphere.
- ▶ Slowly open gas isolating valve.
- ✓ The gas/air mixture in the valve train vents via the hose to safe atmosphere.
- ▶ Close gas isolating valve.
- ▶ Remove vent hose and immediately close test point.
- ▶ Use a test burner to ensure no air is present in the valve train.

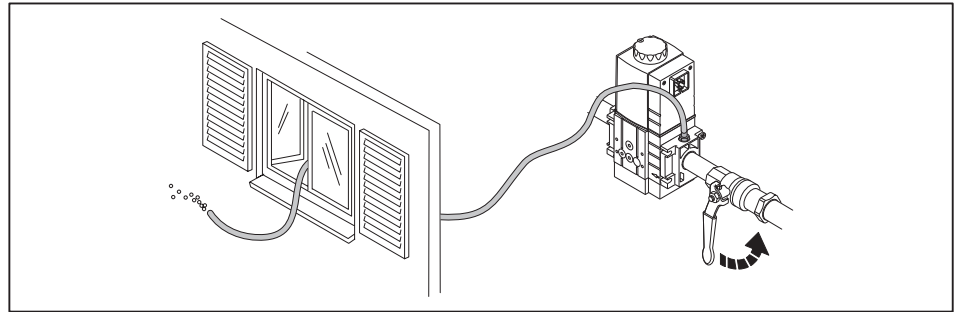

7 Commissioning

7.1.5 Preset pressure regulator

Determine setting pressure



Add the combustion chamber pressure in mbar to the setting pressure into the gas butterfly valve.

► Determine setting pressure from the table and note down.

The details given for calorific value H_i relate to 0 °C and 1013 mbar.

The table values have been calculated under ideal conditions. The values are therefore guide values for basic settings.

Full load [kW]	Ignition load setting pressure [mbar]	Full load setting pressure [mbar]	Min. connection pressure into isolating valve [mbar] (low pressure supply)	
Nominal diameter valve train			3/4"	3/4"
Multifunction assembly W-MF SLE			507	507
Isolating valve			3/4"	1"
Natural Gas E: $H_i = 10.35 \text{ kWh/m}^3$, $d = 0.606$				
40	4.0	6.5	10	10
50	4.0	7.5	10	10
60	4.0	8.1	10	10
70	4.0	8.1	10	10
80	4.2	8.1	10	10
90	4.3	8.3	11	11
100	4.4	8.7	12	11
110	4.6	9.3	13	12
Natural Gas LL: $H_i = 8.83 \text{ kWh/m}^3$, $d = 0.641$				
40	4.9	7.5	12	12
50	5.1	9.1	12	12
60	5.1	10.2	12	12
70	5.3	10.5	12	12
80	5.4	10.5	13	13
90	5.5	10.8	14	14
100	6.1	10.8	15 ⁽¹⁾	14
110	6.5	11.8	16 ⁽¹⁾	15
Liquid Petroleum Gas: $H_i = 25.89 \text{ kWh/m}^3$, $d = 1.555$ The selection is calculated for Propane, it can however, also be used for Butane.				
40	4.0	8.1	8	–
50	4.0	9.2	8	–
60	4.0	9.7	9	–
70	4.0	9.7	9	–
80	4.0	9.7	10	–
90	4.3	10.1	11	–
100	4.8	10.7	12	–
110	5.5	11.9	12	–

⁽¹⁾ Not TRGI compliant.

Preset setting pressure



Only in conjunction with W-MF and gas connection pressure > 150 mbar

The pre-pressure must be set to approx. 90 mbar.

► Set FRS pressure regulator, see additional sheet (print No. 835109xx).

► Pre-set setting pressure determined for ignition load ② and full load ① at multi-function assembly.

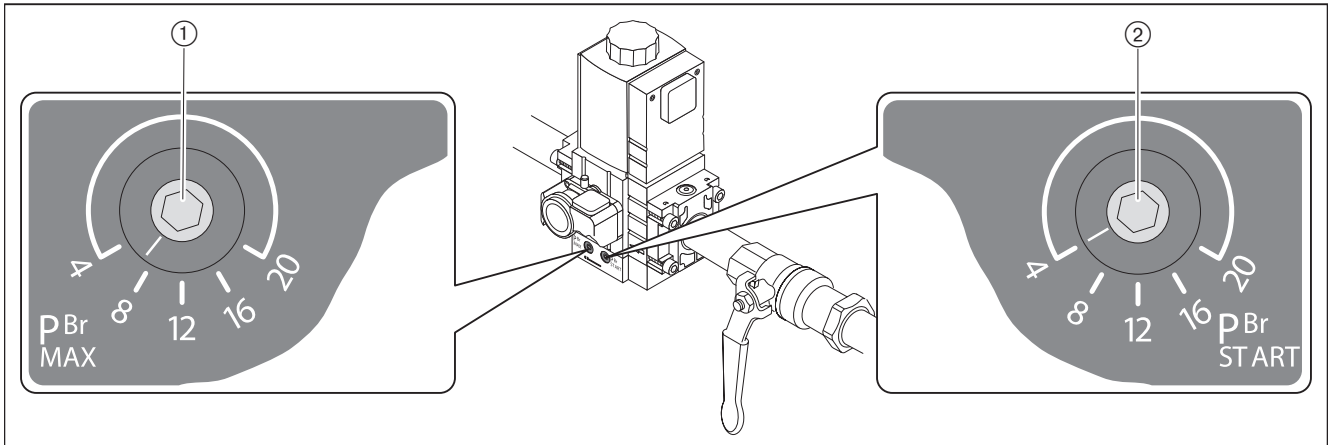

	Setting	Factory presetting
①	Full load	7 mbar
②	Ignition load	4 mbar

The transition from ignition load to full load is carried out sliding.

7 Commissioning

7.1.6 Setting values

Set mixing head relative to the combustion heat rating required. For this, the diffuser setting and the air damper setting should be matched.

Determine diffuser setting and air damper setting



Do not operate the burner outside of the capacity graph [ch. 3.4.6].

► Determine the diffuser setting (dimension X) and air damper setting required from the diagram and note down.

Example

Burner capacity required	90 kW
Diffuser setting (dimension X)	7.2 mm
Air damper setting	6.6

Diffuser default settings

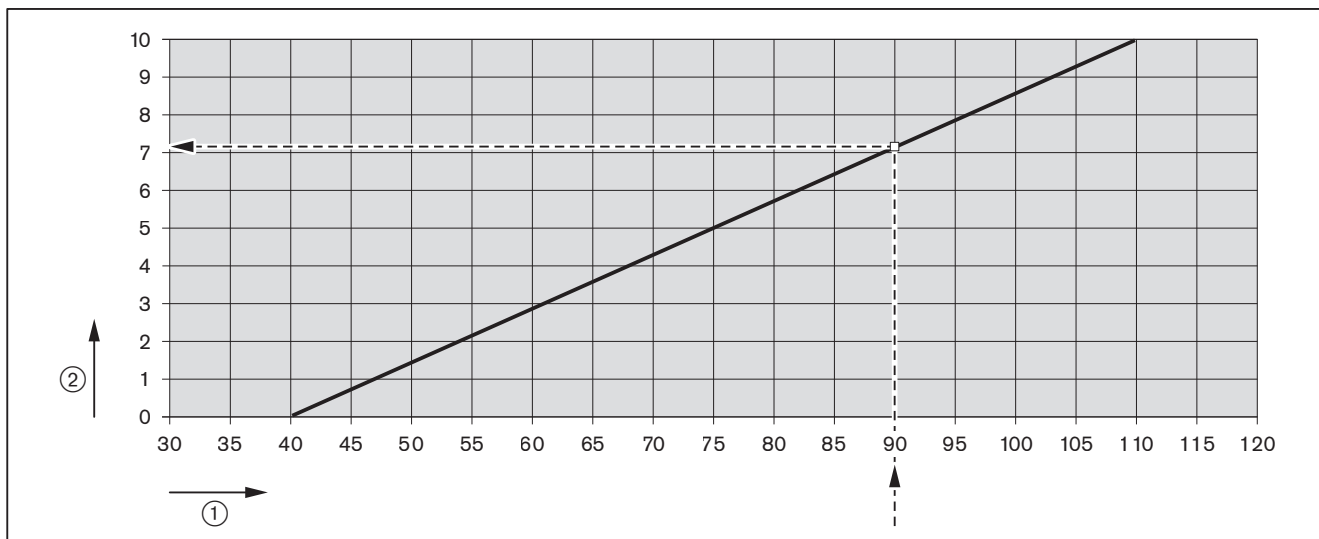

- ① Combustion heat rating [kW]
- ② Diffuser settings (dimension X) [mm]

Air damper default settings

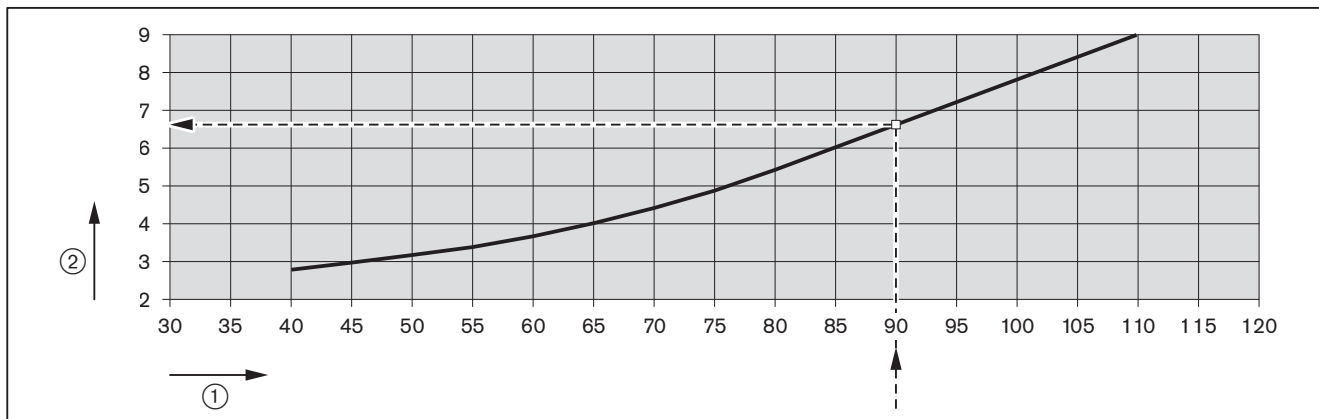

- ① Combustion heat rating [kW]
- ② Air damper setting

Set diffuser

With dimension $X = 0\text{mm}$ the indicating bolt is flush with nozzle assembly cover.

- Turn screw ①, until dimension X equals the value determined.

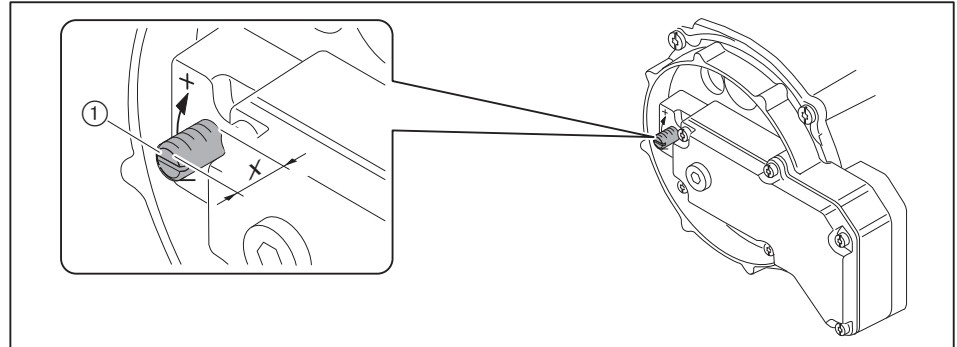

Set air damper

- Turn setting screw ① until the scale shows the value determined.

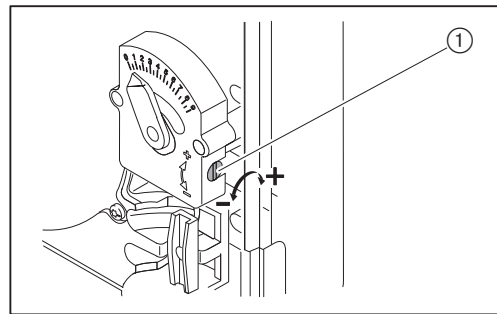

Gas butterfly valve setting screw

The factory setting of gas butterfly valve screws 1 ... 3 must not be altered.
Factory setting: 3 rotations OPEN.

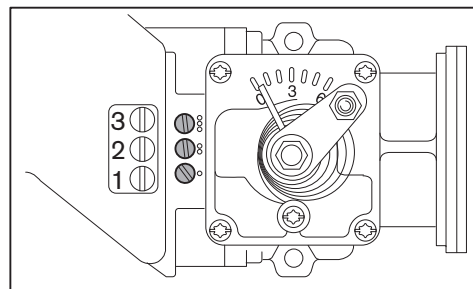

7 Commissioning

Determine mixing pressure

- ▶ Determine the mixing pressure required for the preset combustion heat rating from the diagram and note down.

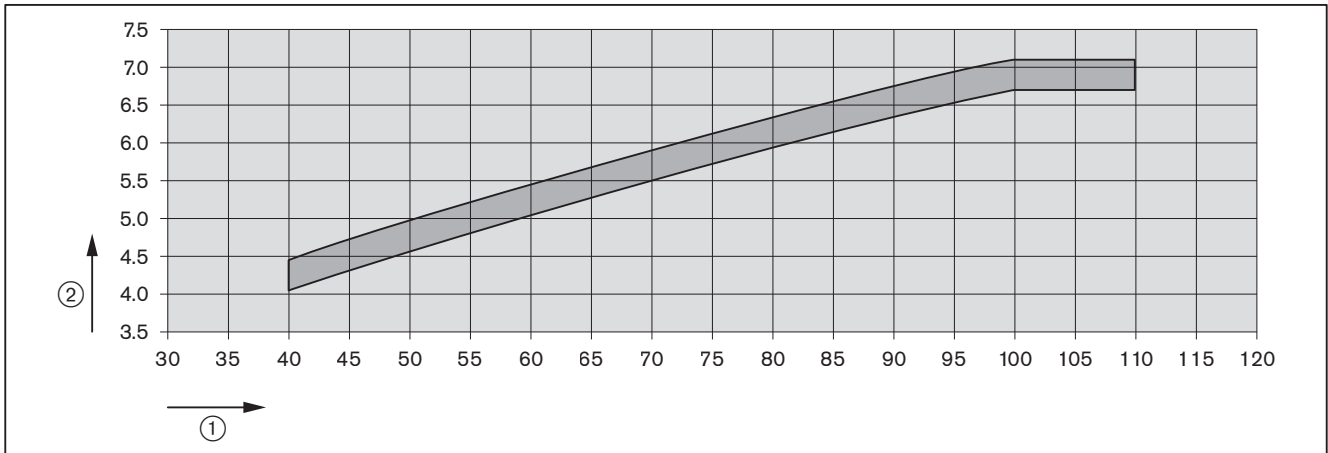

- ① Combustion heat rating [kW]
- ② Mixing pressure [mbar]
- Guide values, which could vary depend. on comb. chamber resistance.

7.1.7 Preset gas and air pressure switch

The presetting of the pressure switches is only valid during commissioning. Once commissioning has been completed the pressure switches must be set correctly [ch. 7.3].

Air pressure switch	approx. 3.5 mbar
Low gas pressure switch/valve proving gas pressure switch	12 mbar
High gas pressure switch (optional)	approx. twice control pressure

7 Commissioning

7.2 Adjusting the burner



Risk of electric shock

Touching the ignition device can lead to electric shock.

- ▶ Do not touch ignition device during the ignition process.

- ▶ During commissioning check:
 - flame signal [ch. 7.1.1],
 - mixing pressure [ch. 7.1.6].

1. Check sequence of operation

- ▶ Open gas isolating valve.
- ✓ Pressure in gas valve train increases.
- ▶ Close isolating valve.
- ▶ Switch on voltage supply.
- ✓ Illuminated push button lights up red.
- ▶ Press illuminated push button for 1 second.
- ✓ Burner starts in accordance with the programme sequence [ch. 3.3.4].
- ▶ Check sequence of operation:
 - Valves open.
 - Gas pressure switch reacts.
 - Burner start is interrupted.
 - Low gas programme starts, the illuminated button flashes red.

2. Adjust setting pressure

- ▶ Open test point for setting pressure and connect pressure measuring device.

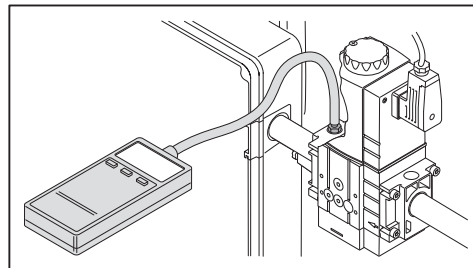

- ▶ Open gas isolating valve.
- ▶ Press illuminated push button of combustion manager
- ✓ Low gas program is reset.
- ✓ Burner starts in accordance with the programme sequence.
- ▶ Preset setting pressure determined at multifunction assembly [ch. 7.1.5].

3. Adjust combustion

When adjusting, the ratings data given by the boiler manufacturer and the capacity graph of the burner should be observed [ch. 3.4.6].

- ▶ Check CO content of combustion and if necessary adjust combustion values via air damper and/or diffuser. Observe mixing pressure while doing so.
- ▶ Calculate gas throughput (operating volume V_B) required [ch. 7.6].
- ▶ Optimise setting pressure until gas throughput (V_B) is achieved.
- ▶ Check combustion values
- ▶ Determine combustion limit and set excess air via air damper and/or diffuser [ch. 7.5].
- ▶ Determine gas throughput once more and adjust if necessary.
- ▶ Re-set excess air.

4. Check start behaviour

- ▶ Switch off and restart burner.
- ▶ Check start behaviour and if necessary correct ignition position.

If the ignition position has been altered:

- ▶ Re-check start behaviour.

7.3 Set pressure switches

7.3.1 Set gas pressure switch

Set low gas pressure switch

The switch point must be checked and if necessary adjusted during commissioning.

- ▶ Connect pressure measuring device to test point ① of the gas pressure switch.
- ▶ Start the burner.
- ▶ Slowly close gas isolating valve until either:
 - the O₂ content in the flue gas increases to above 7 %,
 - the flame stability considerably worsens,
 - the CO content increases,
 - or the gas flow pressure drops to 50 %.
- ▶ Determine gas pressure.
- ▶ Slowly open gas isolating valve.
- ▶ Set the pressure determined as switch point at the setting cam ②.

Check switch point

- ▶ Restart the burner.
- ▶ Slowly close gas isolating valve.
- ✓ If the low gas program starts, the gas pressure switch has been set correctly.
- ✓ If a lockout occurs or if the combustion reaches a critical condition, the low gas pressure switch reacts too late.

If lockout occurs:

- ▶ Increase switch point at setting cam ②.
- ▶ Slowly open gas isolating valve.
- ▶ Re-check switch point.

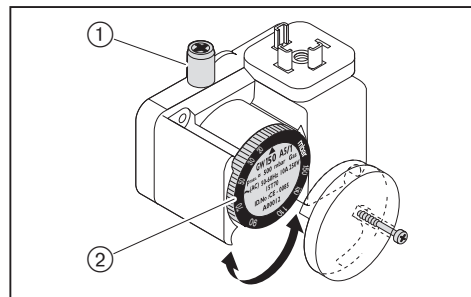

Set (optional) high gas pressure switch

- ▶ Set high gas pressure switch to $1.3 \times P_{\text{Gas full load}}$ (flow pressure at full load).

7.3.2 Set air pressure switch

The switch point must be checked and if necessary adjusted during commissioning.

- ▶ Connect pressure measuring device for differential pressure measurement.
- ▶ Start the burner.
- ▶ Carry out differential pressure measurement across the whole capacity range of the burner and determine the lowest differential pressure.
- ▶ Calculate switch point (80 % of release pressure or lowest differential pressure).
- ▶ Set the switch point determined at the setting cam ①.

Example

Lowest differential pressure	3.2 mbar
Switch point air pressure switch (80 %)	$3.2 \text{ mbar} \times 0.8 = 2.6 \text{ mbar}$

Site specific influences on the air pressure, (e.g. by the flue gas system, heat exchanger, installation location or air supply) may make it necessary to vary the setting of the air pressure switch.

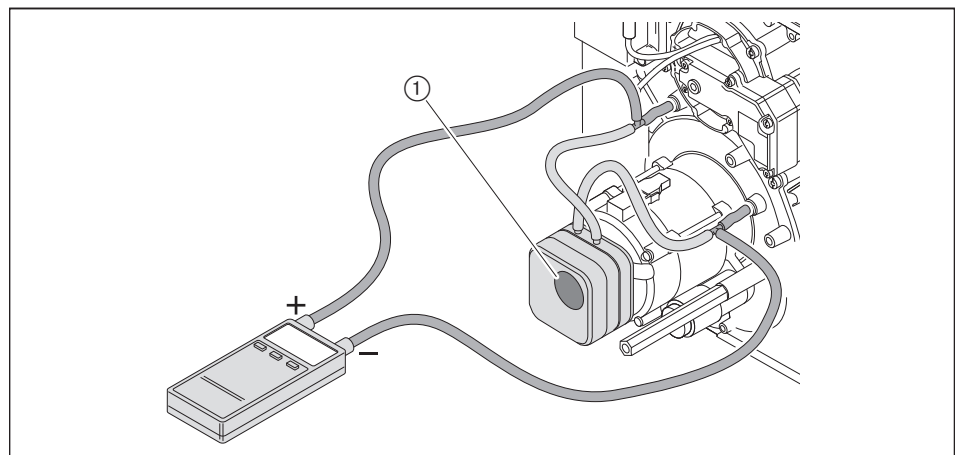

7 Commissioning

7.4 Concluding work

- ▶ Check control and safety devices.
- ▶ Remove gas pressure measuring devices and close all test points.
- ▶ Conclude valve proving of gas valve train (fourth test phase) [ch. 7.1.3].
- ▶ Enter combustion values and settings in the commissioning record and/or test sheet.
- ▶ Mount cover on burner.
- ▶ Inform the operator about the use of the equipment.
- ▶ Hand the installation and operating manual to the operator and inform him that this should be kept with the appliance.
- ▶ Point out to operator that the installation should be serviced annually.

7.5 Check combustion

Determine excess air

- ▶ Slowly close air damper(s) in the relevant operating point, until the combustion limit is reached (CO content approx. 100 ppm).
- ▶ Measure and document O₂ content.
- ▶ Read air number (λ).

Increase air number to ensure sufficient excess air:

- by 0.15 ... 0.2 (equates to 15 ... 20 % excess air),
- by more than 0.2 for more difficult conditions, such as:
 - dirty combustion air,
 - fluctuating intake temperature,
 - fluctuating chimney draught.

Example

$$\lambda + 0.15 = \lambda^*$$

- ▶ Set air number (λ*), do not exceed CO content of 50 ppm.
- ▶ Measure and document O₂ content.

Check flue gas temperature

- ▶ Check flue gas temperature.
- ▶ Ensure that the flue gas temperature complies with the data provided by the boiler manufacturer.
- ▶ If necessary adjust flue gas temperature, e.g.:
 - Increase burner capacity to avoid condensation in the flue gas ducts, except on condensing units.
 - Reduce burner capacity to improve efficiency.
 - Adjust heat exchanger to the data provided by the manufacturer.

Determine flue gas losses

- ▶ Measure combustion air temperature (t_L) near the air damper(s).
- ▶ Measure oxygen content (O₂) and flue gas temperature (t_A) at the same time at one point.
- ▶ Determine flue gas losses using the following formula:

$$q_A = (t_A - t_L) \cdot \left(\frac{A_2}{21 - O_2} + B \right)$$

- q_A Flue gas losses [%]
- t_A Flue gas temperature [°C]
- t_L Combustion air temperature [°C]
- O₂ Volumetric content of oxygen in dry flue gas [%]

Fuel factors	Natural Gas	Liquid Petroleum Gas
A ₂	0,66	0,63
B	0.009	0.008

7 Commissioning

7.6 Calculate gas throughput

Formula symbol	Explanation	Example values
V_B	Operating volume [m ³ /h] Volume measured at gas meter at current pressure and temperature (gas throughput).	–
V_N	Standard volume [m ³ /h] Volume gained by gas at 1013 mbar and 0 °C.	–
f	Conversion factor	–
Q_N	Heat rating [kW]	200 kW
η	Boiler efficiency (e. g. 92 % \pm 0.92)	0,92
H_i	Calorific value [kWh/m ³] at 0 °C and 1013 mbar	10.35 kW/m ³ (Natural Gas E)
t_{Gas}	Gas temperature at gas meter [°C]	10 °C
P_{Gas}	Pressure at gas meter [mbar]	25 mbar
P_{Baro}	Barometric air pressure [mbar], see table	500 m \pm 955 mbar
V_G	Gas throughput determined at gas meter	0.74 m ³
T_M	Measuring time [seconds]	120 seconds

Calculate normal volume

- ▶ Calculate the normal volume (V_N) using the following formula.

$$V_N = \frac{Q_N}{\eta \cdot H_i} \quad V_N = \frac{200 \text{ kW}}{0,92 \cdot 10.35 \text{ kW/m}^3} = 21.0 \text{ m}^3/\text{h}$$

Calculate conversion factor

- ▶ Determine gas temperature (t_{Gas}) and pressure (P_{Gas}) at gas meter.
- ▶ Determine barometric air pressure (P_{Baro}) from table.

Height above sea level [m]	0	100	200	300	400	500	600	700	800	900	1000	1100	1200	1300
P_{Baro} [mbar]	1013	1001	990	978	966	955	943	932	921	910	899	888	877	866

- ▶ Calculate conversion factor (f) using the following formula.

$$f = \frac{P_{Baro} + P_{Gas}}{1013} \cdot \frac{273}{273 + t_{Gas}} \quad f = \frac{955 + 25}{1013} \cdot \frac{273}{273 + 10} = 0.933$$

Calculate operating volume (gas throughput) required

$$V_B = \frac{V_N}{f} \quad V_B = \frac{21.0 \text{ m}^3/\text{h}}{0.933} = 22.5 \text{ m}^3/\text{h}$$

Determine current operating volume (gas throughput)

- ▶ Measure gas throughput (V_G) at gas meter, measuring time (T_M) should be a minimum of 60 seconds.
- ▶ Calculate operating volume (V_B) using the following formula.

$$V_B = \frac{3600 \cdot V_G}{T_M} \quad V_B = \frac{3600 \cdot 0.74 \text{ m}^3}{120 \text{ s}} = 22.2 \text{ m}^3/\text{h}$$

8 Shutdown

For breaks in operation:

- ▶ Switch off burner.
- ▶ Close fuel shut off devices.

9 Servicing

9 Servicing

9.1 Notes on servicing



Risk of explosion due to leaking gas

Improper service work can lead to escaping gas and explosion.

- ▶ Close fuel shut off devices prior to starting work.
- ▶ Care should be taken when dismantling and assembling gas carrying components.
- ▶ Close the screws on the test points ensuring the tests points are sealed.



Risk of electric shock

Working on the device when voltage is applied can lead to electric shock.

- ▶ Isolate the device from the power supply prior to starting any work.
- ▶ Safeguard against accidental restart.



Danger of getting burned on hot components

Hot components can lead to burns.

- ▶ Allow components to cool.

Servicing must only be carried out by qualified personnel. The combustion plant should be serviced annually. Depending on site conditions more frequent checks may be required.

Components, which show increased wear and tear or whose design lifespan is or will be exceeded prior to the next service should be replaced as a precaution.

The design lifespan of the components is listed in the service plan [ch. 9.2].



Weishaupt recommends a service contract is entered into to ensure regular inspections.

The following components must only be replaced and must not be repaired:

- combustion manager
- flame sensor
- multifunction assembly
- pressure regulator
- pressure switch

Prior to every servicing

- ▶ Inform the operator about the extent of service work to be carried out.
- ▶ Switch off mains switch of installation and safeguard against accidental reactivation.
- ▶ Close fuel shut off devices.
- ▶ Remove cover.
- ▶ Unplug boiler control connection plug from combustion manager.

Following servicing



Risk of electric shock

Touching the ignition device can lead to electric shock.

- ▶ Do not touch ignition device during the ignition process.

- ▶ Check tightness of gas carrying components.
- ▶ Check function of:
 - ignition,
 - flame monitoring,
 - gas carrying components (gas connection pressure and setting pressure),
 - pressure switch,
 - control and safety devices.
- ▶ Check combustion values, if necessary re-adjust the burner.
- ▶ Enter combustion values and settings in the commissioning record.
- ▶ Refit cover.

9.2 Service plan

Components	Criteria / design lifespan ⁽¹⁾	Service procedure
Fan wheel	Soiling	▶ Clean
	Damage	▶ Replace
Air duct	Soiling	▶ Clean
Air damper	Soiling	▶ Clean
Air pressure switch	Switch point	▶ Check
	250 000 burner starts or 10 years ⁽²⁾	▶ Replace
Ignition cable	Damage	▶ Replace
Ignition electrode	Soiling	▶ Clean
	Damage/wear	▶ Replace
Combustion Manager	250 000 burner starts or 10 years ⁽²⁾	▶ Replace
Ionisation cable	Damage	▶ Replace
Ionisation electrode	Soiling	▶ Clean
	Damage/wear	▶ Replace Recommendation: at least every 2 years
Flame tube/diffuser	Soiling	▶ Clean
	Damage	▶ Replace
Multifunction assembly	Function / soundness	▶ Replace
	250 000 burner starts or 10 years ⁽²⁾	
Breather plug multifunction assembly	Soiling	▶ Replace
Filter insert multifunction assembly	Soiling	▶ Replace
Gas pressure regulator	Setting pressure	▶ Check
	Function / soundness	▶ Replace
	15 years	▶ Replace
Gas pressure switch	Switch point	▶ Check
	50 000 burner starts or 10 years ⁽²⁾	▶ Replace

⁽¹⁾ The specified design lifespan applies for typical use in heating, hot water and steam systems as well as for thermal process systems to EN 746.

⁽²⁾ If a criterion is reached, carry out maintenance measures.

9 Servicing

9.3 Removing and refitting mixing head

Observe notes on servicing [ch. 9.1].



Risk of explosion due to leaking gas

It is possible for gas to leak out if the gasket ③ is seated incorrectly.

- ▶ Following work on the mixing head, ensure the gasket is clean and seated correctly, if necessary replace.
- ▶ Check for leaks, see Fourth test phase [ch. 7.1.3].

Removing

- ▶ Unplug ionisation cable ⑤.
- ▶ Unplug ignition cable ①.
- ▶ Undo screws ④.
- ▶ Turn mixing head ② to the left up to the recess and remove.

Refitting

- ▶ Refit mixing head in reverse order ensuring correct alignment and cleanliness of gasket ③.

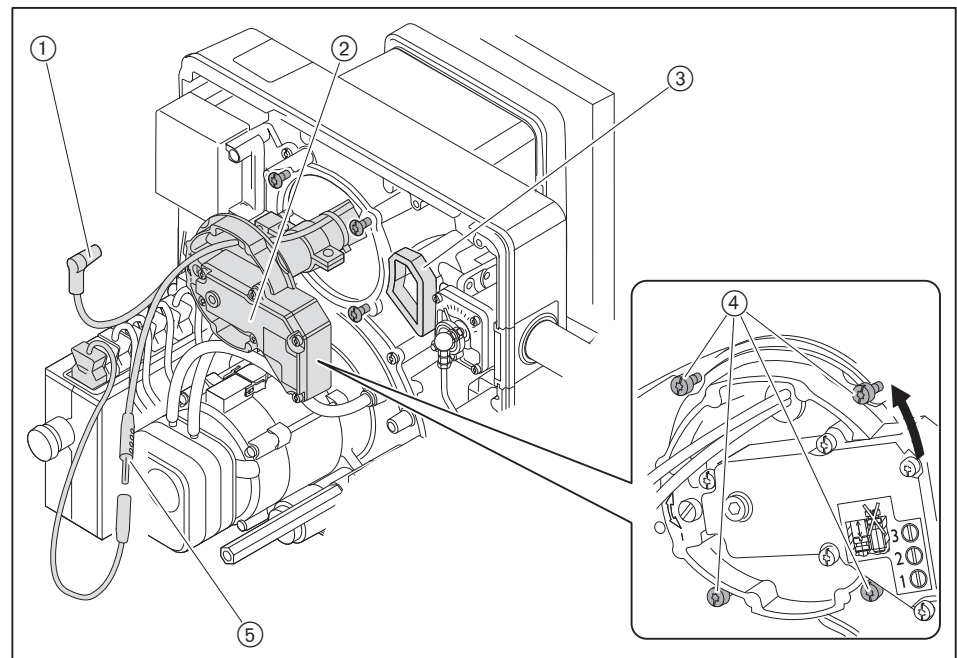

9.4 Set mixing head

Observe notes on servicing [ch. 9.1].

The distance between diffuser and flame tube front edge S1 can not be measured with the burner mounted. This is only possible indirectly with the mixing head removed, with dimension Lx.



Dimension Lx changes according to the combustion head extension used.

- ▶ Remove mixing head [ch. 9.3].
- ▶ Turn setting screw ① until it is flush with the nozzle assembly cover (dimension X = 0 mm).
- ▶ Check dimension Lx.

If the value measured deviates from dimension Lx:

- ▶ Undo screws ②.
- ▶ Adjust flame tube ③ until dimension Lx has been reached.
- ▶ Re-tighten screws ②.

If the screws ② have been loosened:

- ▶ Check position of electrodes and gas orifices ④.

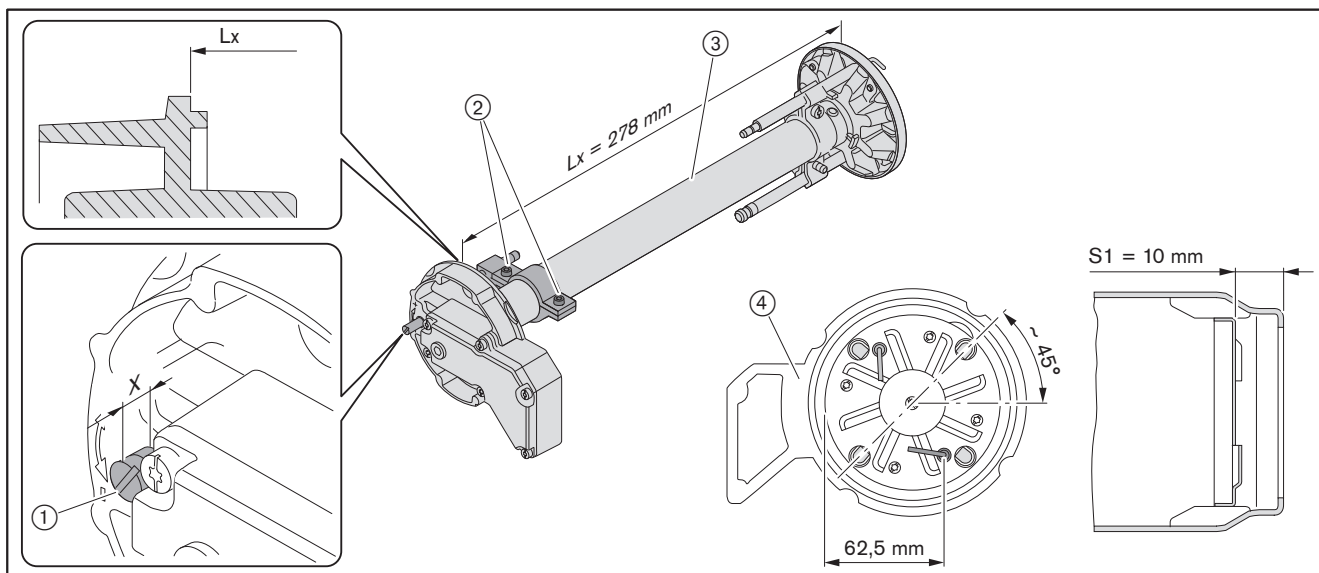

9 Servicing

9.5 Set ionisation and ignition electrodes

Observe notes on servicing [ch. 9.1].

- ▶ Remove mixing head [ch. 9.3].
- ▶ Undo screw ①.
- ▶ Set ignition electrode and re-tighten screw.
- ▶ Undo screw ②.
- ▶ Set ionisation electrode and re-tighten screw.

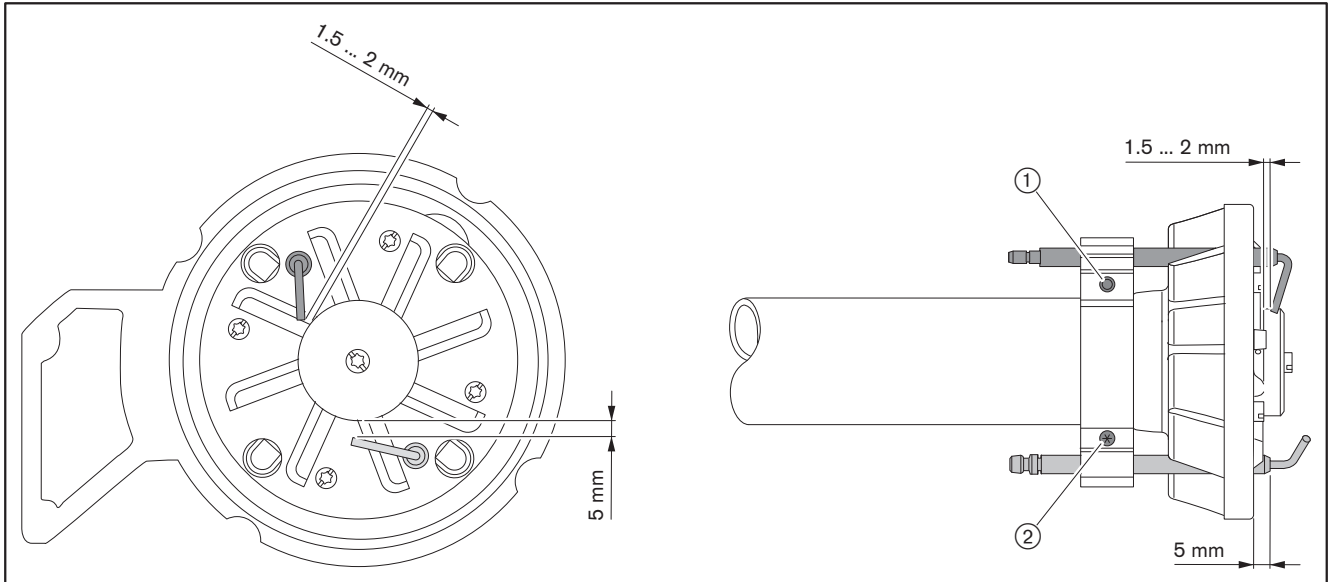

9.6 Service position

Observe notes on servicing [ch. 9.1].



The burner mounted rotated by 180° cannot be placed into the service position.

- ▶ Remove mixing head [ch. 9.3].
- ▶ Hold housing cover and remove screws ①.
- ▶ Place housing cover into service position ②.

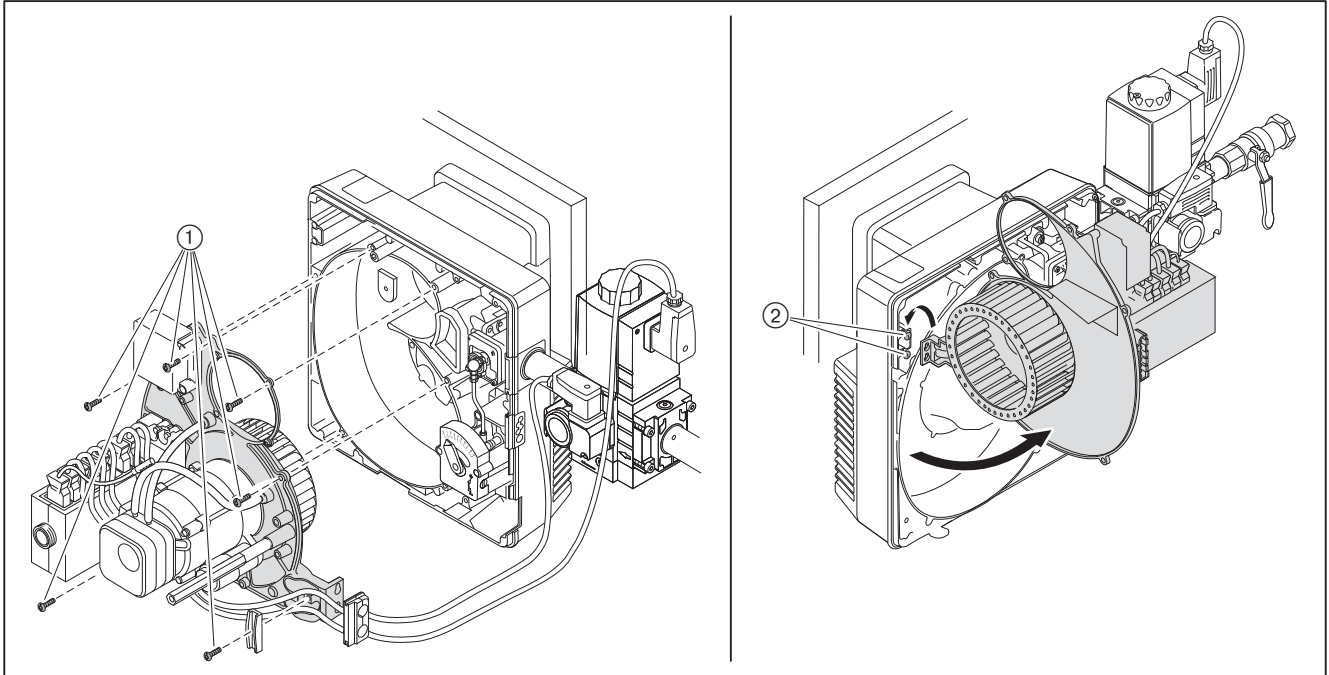

9 Servicing

9.7 Removing and refitting fan wheel

Observe notes on servicing [ch. 9.1].

Removing

- ▶ Place housing cover into service position [ch. 9.6].
- ▶ Remove grub screw ① and remove fan wheel.

Refitting

- ▶ Refit fan wheel in reverse order and
 - ensure correct alignment on the motor shaft ②,
 - screw in new grub screw ①,
 - turn fan wheel to ensure it moves freely.

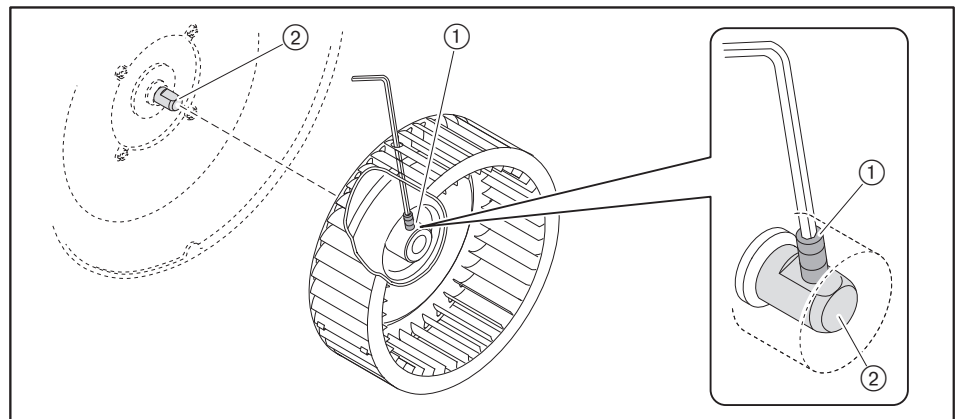

9.8 Remove burner motor

Observe notes on servicing [ch. 9.1].

- ▶ Remove fan wheel [ch. 9.7].
- ▶ Unplug plug number 3 and 11.
- ▶ Disconnect + and - hoses.
- ▶ Undo screws ① and remove air pressure switch.
- ▶ Hold motor and remove screws ②.
- ▶ Remove motor.

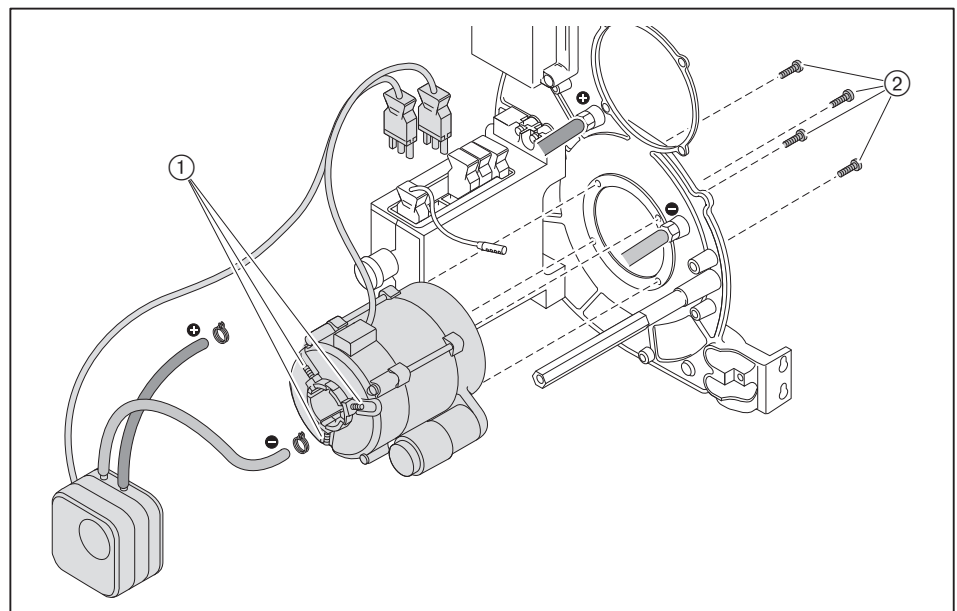

9.9 Removing and refitting manual adjustment of air damper

Observe notes on servicing [ch. 9.1].

Removing

- ▶ Remove screws ①.
- ▶ Remove manual adjustment.

Refitting

- ▶ Insert manual adjustment into the star shaped groove ② and secure.

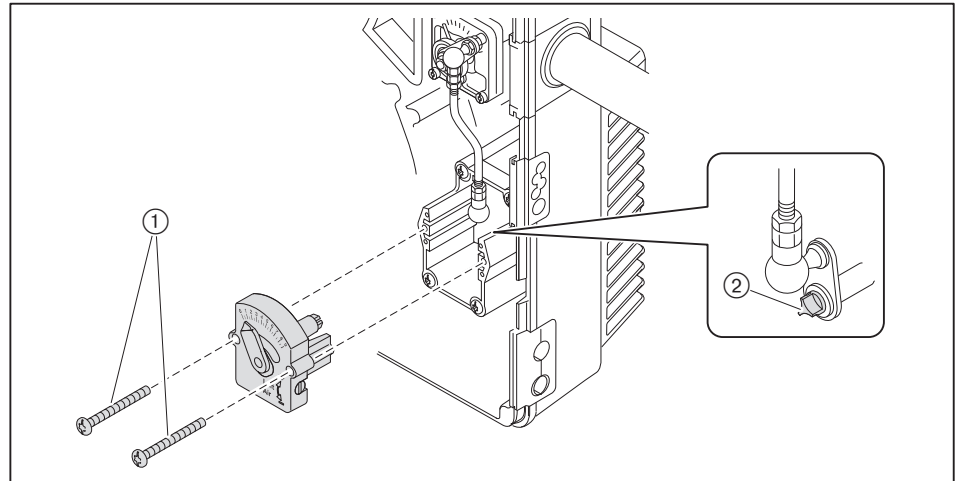

9 Servicing

9.10 Removing and refitting angle drive

Observe notes on servicing [ch. 9.1].

Removing

- ▶ Remove manual adjustment of air damper [ch. 9.9].
- ▶ Pull drive rod ③ from the gas butterfly valve ⑧ and remove.
- ✓ Air damper is opened by the force of the spring.
- ▶ Remove frame ④.
- ▶ Remove angle drive ⑤.

Refitting

- ▶ Remove intake housing [ch. 9.12].
- ▶ Open air damper ⑥ until position ⑦ has been reached and hold tight.
- ▶ Fit angle drive to shaft.
- ▶ Secure angle drive.
- ▶ Mount intake housing.
- ▶ Fit frame ④.
- ▶ Place drive rod ③ into manual adjustment.
- ▶ Turn indicator ① to CLOSED position and hold.
- ▶ Place manual adjustment with drive rod ③ into the star shaped groove ② and secure.
- ▶ Engage drive rod on gas butterfly valve ⑧, ensuring correct alignment.

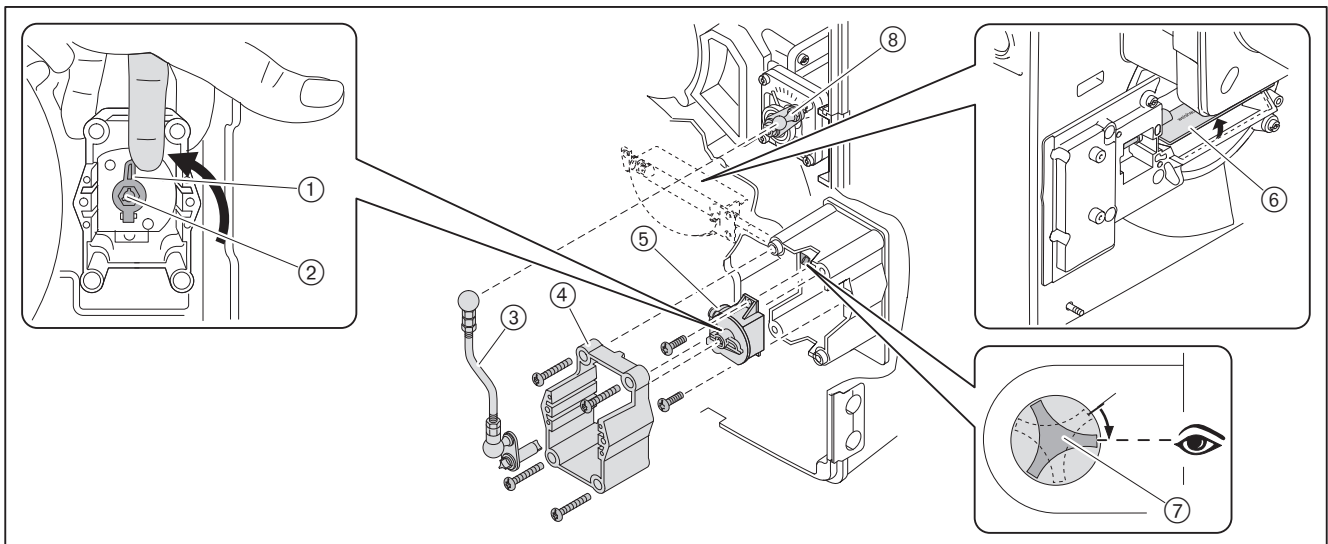

9.11 Removing and refitting gas butterfly valve

Observe notes on servicing [ch. 9.1].

Removing

- ▶ Remove screws ③.
- ▶ Unscrew flange with double nipple ④.
- ▶ Remove mixing head [ch. 9.3].
- ▶ Remove drive rod ⑥.
- ▶ Remove screws ① and remove gas butterfly valve ②.

Refitting

- ▶ Refit gas butterfly valve ② in reverse order and:
 - ensure correct alignment of drive rod ⑥ with gas butterfly valve,
 - secure flange to multifunction assembly whilst ensuring correct seating of O ring ⑤ on the flange.

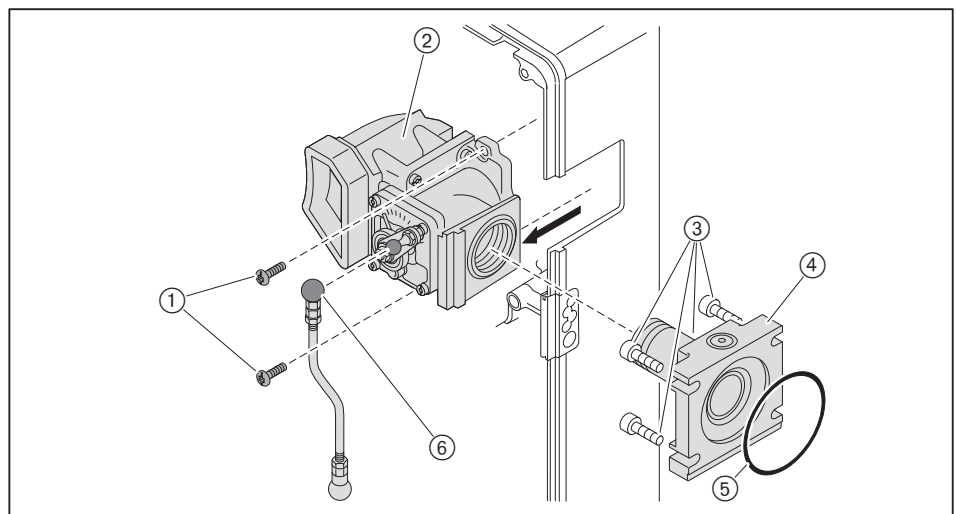

- ▶ Carry out soundness test [ch. 7.1.3].

9 Servicing

9.12 Removing and refitting air regulator

Observe notes on servicing [ch. 9.1].

Removing

- ▶ Remove bolts ①.
- ▶ Remove burner from heat exchanger [ch. 4.2].
- ▶ Remove bolts ②.
- ▶ Remove intake housing ⑤.
- ▶ Remove bolts ④.
- ▶ Remove air regulator ③.

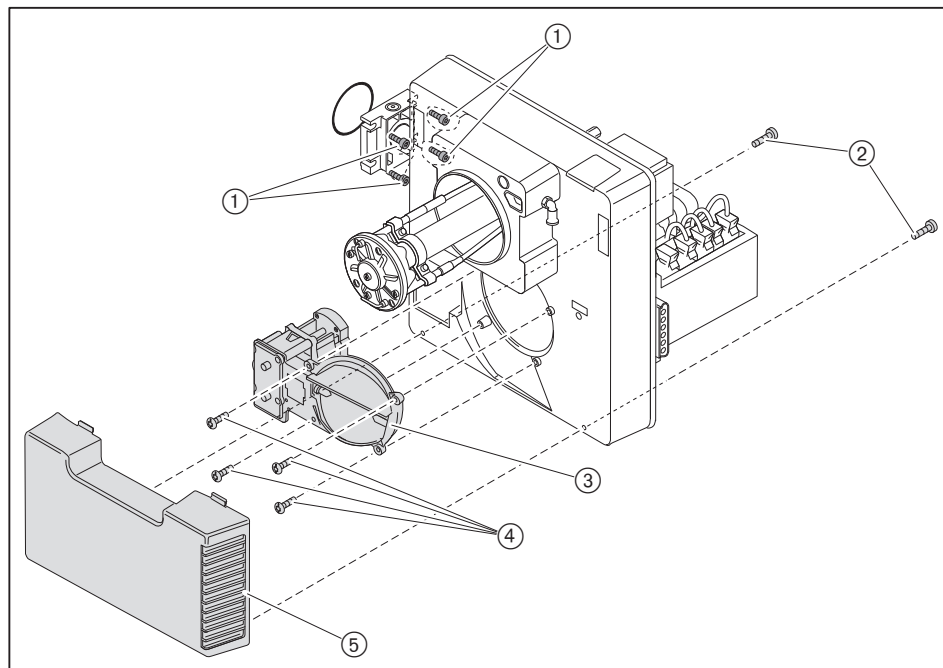

Refitting

- ▶ Refit air regulator in reverse order.
- ▶ Carry out soundness test [ch. 7.1.3].

9.13 Replacing coil on multifunction assembly

Observe notes on servicing [ch. 9.1].



Ensure correct voltage and solenoid number when replacing the solenoid coil.

- ▶ Undo screw ①.
- ▶ Remove cap ②.
- ▶ Replace solenoid coil ③.

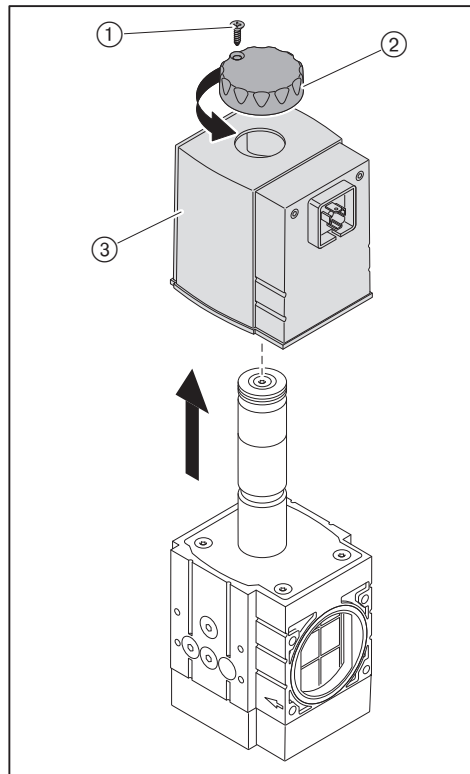

9.14 Replace breather plug of multifunction assembly

Observe notes on servicing [ch. 9.1].

A breather plug with integrated filter is fitted to protect the breather orifice against soiling.

- ▶ Replace breather plug ①.

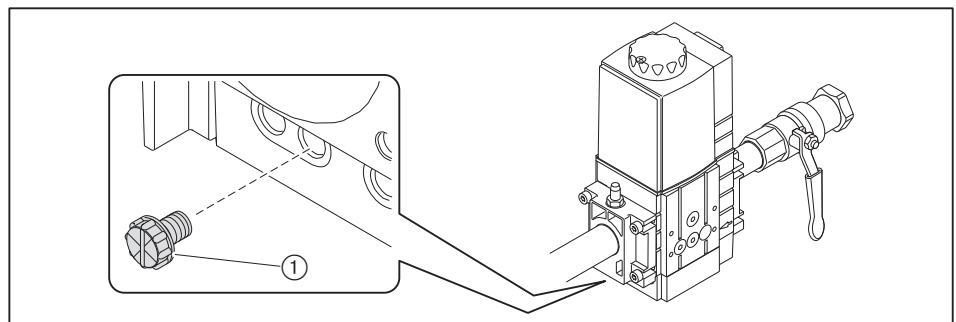

9 Servicing

9.15 Removing and refitting filter insert of multifunction assembly

Observe notes on servicing [ch. 9.1].



Ensure no dirt enters the multifunction assembly when removing and replacing the filter insert.

Removing

- ▶ Remove screws ④.
- ▶ Remove cover ③.
- ▶ Remove filter insert ①.
- ▶ If necessary replace filter insert ① and seal ②.

Refitting

- ▶ Refit in reverse order ensuring correct alignment of filter ① and seal ②.

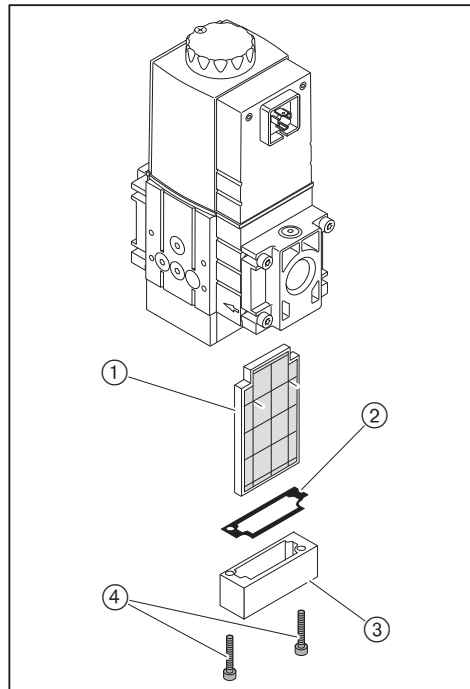

- ▶ Carry out soundness test [ch. 7.1.3].
- ▶ Vent gas valve train [ch. 7.1.4].

9.16 Replacing the fuse

Observe notes on servicing [ch. 9.1].

- ▶ Remove all plugs from the combustion manager.
- ▶ Remove screws from the combustion manager.
- ▶ Remove combustion manager.
- ▶ Replace fuse (T6.3H, IEC 127-2/5).

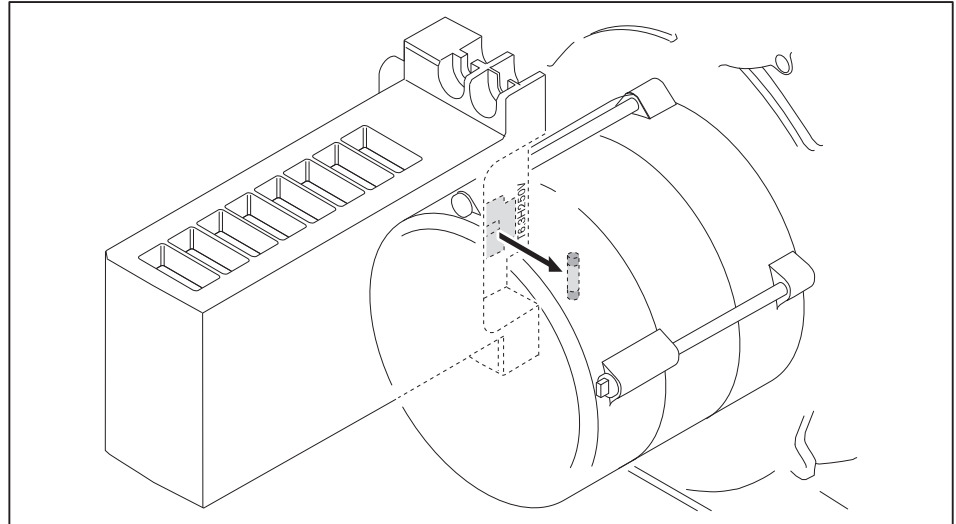

10 Troubleshooting

10 Troubleshooting

10.1 Procedures for fault conditions

The combustion manager recognises irregularities of the burner and indicates these with the illuminated push button.

The following conditions can occur:

- illuminated push button off [ch. 10.1.1],
- illuminated push button red [ch. 10.1.2],
- illuminated push button flashes [ch. 10.1.3].

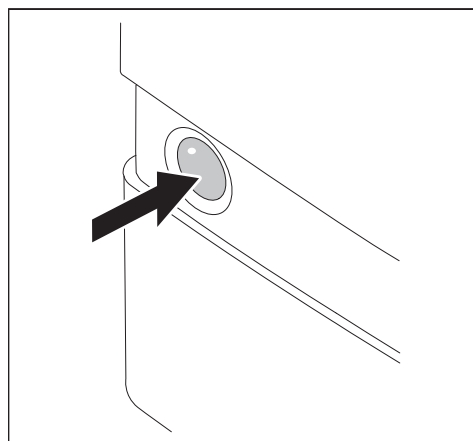

10.1.1 Illuminated push button off

The following faults may be corrected by the operator:

Fault	Cause	Rectification
Burner not operating	External fuse has tripped ⁽¹⁾	▶ Check fuse.
	Heating switch is set to Off	▶ Switch on heating switch.
	Temperature limiter or pressure limiter on heat exchanger has triggered ⁽¹⁾	▶ Reset temperature limiter or pressure limiter on heat exchanger.
	Low water safety interlock on heat exchanger has triggered ⁽¹⁾	▶ Top up water. ▶ Reset low water safety interlock on heat exchanger.
	Temperature regulator or pressure regulator on heat exchanger has been set incorrectly	▶ Adjust temperature regulator or pressure regulator on heat exchanger.
	Boiler or heating circuit control is not functioning or has not been set correctly	▶ Check function and setting of boiler or heating circuit control.

⁽¹⁾ Notify your heating contractor or Weishaupt Customer Service if the problem occurs repeatedly.

10.1.2 Illuminated push button red

A burner fault has occurred. The burner is in lockout. Prior to resetting, the error code can be called up and used to control the cause of the fault.

Read error code

Only 5 seconds after a fault occurred can it be analysed and read.

- ▶ Press illuminated push button for 5 seconds.
- ✓ Illuminated push button briefly lights up orange.
- ✓ Illuminated push button flashes red.
- ▶ Count between the flashing pauses and flashing signals and note down.
- ▶ Rectify cause of fault, see table.

Resetting



Damage resulting from incorrect fault repair

Incorrect fault repair can cause damage to the equipment and injure personnel.

- ▶ Do not carry out more than 2 lockout resets successively.
- ▶ Faults must be rectified by qualified personnel.

-
- ▶ Press illuminated push button for 1 second.
 - ✓ Red signal extinguishes.
 - ✓ Burner has been reset.

10 Troubleshooting

Error codes with lockout

The following faults must only be rectified by qualified personnel:

Fault codes	Fault	Cause	Rectification
2 x flashing No flame, end of safety time	No ignition	Ignition electrode set incor- rectly	▶ Set ignition electrode [ch. 9.5]
		Ignition electrode dirty or wet	▶ Clean ignition electrode
		Ceramic insulator defective	▶ Replace ignition elec- trode.
		Ignition cable defective	▶ Replace ignition cable
		Ignition unit defective	▶ Replace ignition unit
	Double gas valve does not open	Cable defective	▶ Check cable, if necessary replace
		Coil defective	▶ Replace coil [ch. 9.13]
	Combustion manager does not detect a flame signal	No ionisation current present or insufficient	▶ Measure ionisation current [ch. 7.1.1] ▶ Set ionisation electrode [ch. 9.5] ▶ Check contact resistance (terminal, plug) ▶ Correct burner setting ▶ When using an un- earthed mains supply (control transformer) the pole which is to be used as neutral conductor must be earthed
		Ionisation electrode worn	▶ Replace ionisation elec- trode
		Ionisation cable defective	▶ Replace cable
Flashing 3 times Air pressure switch fault	Air pressure switch does not react	Hoses not attached tightly	▶ Check hoses on air pres- sure switch
		Air pressure switch set in- correctly	▶ Set air pressure switch [ch. 7.3.2]
		Cable defective	▶ Check cable, if necessary replace
		Air pressure switch defect- ive	▶ Check air pressure switch, if necessary re- place
	Burner motor does not run	Capacitor defective	▶ Replace capacitor
		Cable defective	▶ Check cable, if necessary replace
		Burner motor defective	▶ Check burner motor, if necessary replace
Flashing 4 times Flame simulation/ extraneous light	Flame signal prior to or after operation	Ionisation current present	Extraneous light detection from 0.8 µA ▶ Find and eliminate per- turbation
		Ionisation electrode defect- ive	▶ Check the ionisation electrode, replace if ne- cessary

The following faults must only be rectified by qualified personnel:

Fault codes	Fault	Cause	Rectification
Flashing 7 times Flame failure during operation	Flame signal insufficient	Burner setting incorrect	▶ Check burner setting ▶ Check flame signal
		Ionisation electrode soiled	▶ Clean ionisation electrode
		Ionisation electrode set incorrectly	▶ Set ionisation electrode [ch. 9.5]
		Ionisation electrode defective	▶ Check the ionisation electrode, replace if necessary
Flashing 8 times Gas pressure switch fault	Gas pressure switch does not react	Gas pressure switch set incorrectly	▶ Set gas pressure switch [ch. 7.3.1]
		Gas pressure switch defective	▶ Check gas pressure switch, if necessary replace
Flashing 10 times Combustion manager fault	Burner does not start	Parameters have been changed	▶ Reset burner [ch. 10.1.2]
		Combustion manager defective	▶ Reset burner [ch. 10.1.2], if fault reoccurs replace combustion manager

10 Troubleshooting

10.1.3 Illuminated push button flashes

An irregularity is present. The burner does not go to lockout. Once the fault has been rectified, the error code ceases.

Error codes without lockout

The following faults must only be rectified by qualified personnel:

Fault codes	Cause	Rectification
Flashing green/red	Flame signal at heat demand	▶ Find and eliminate perturbation
	Flame formation caused by leaking solenoid valve	▶ Replace multifunction assembly
Flashing red/orange with pause	Excess voltage	▶ Check voltage supply
Flashing orange/red	Low voltage	▶ Check voltage supply
	Internal unit fuse (F7) faulty	▶ Replace fuse [ch. 9.16]
	Combustion manager fault	▶ Replace combustion manager
Flashing red	Bridging plug No. 2 is missing	▶ Plug in bridging plug No. 2
	Low gas	▶ Check gas connection pressure ▶ Set gas pressure switch [ch. 7.3.1] ▶ Check gas pressure switch
orange, after 2 minutes red	Air pressure switch does not react	▶ Set air pressure switch [ch. 7.3.2] ▶ Check air pressure switch ▶ With ducted air intake air pressure switch, check air supply
Flashing green	Burner operation with weak flame signal	Minimum ionisation current 1.5 µA ▶ Check burner setting
	Ionisation electrode soiled	▶ Clean ionisation electrode
	Ionisation electrode defective	▶ Replace ionisation electrode
Glimmering red	OCl mode activated (not used)	▶ Press illuminated push button for more than 5 seconds ✓ Combustion manager changes to operating mode

10.2 Operating problems

The following faults must only be rectified by qualified personnel:

Observation	Cause	Rectification
Poor start behaviour of burner	Mixing pressure too high	▶ Reduce mixing pressure in ignition position
	Ignition electrode set incorrectly	▶ Set ignition electrode [ch. 9.5]
	Mixing head set incorrectly	▶ Set mixing head [ch. 9.4]
	Ignition load set incorrectly	▶ Set ignition load [ch. 7.2]
Combustion pulsating or burner booming	Mixing head set incorrectly	▶ Set mixing head [ch. 9.4]
	Incorrect combustion air quantity	▶ Adjust burner
Stability problems	Mixing pressure too high	▶ Decrease mixing pressure

11 Technical documentation

11 Technical documentation

11.1 Wiring diagram

For special version observe wiring diagram supplied.

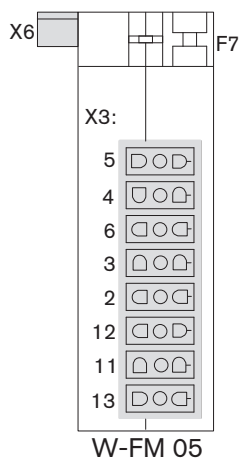
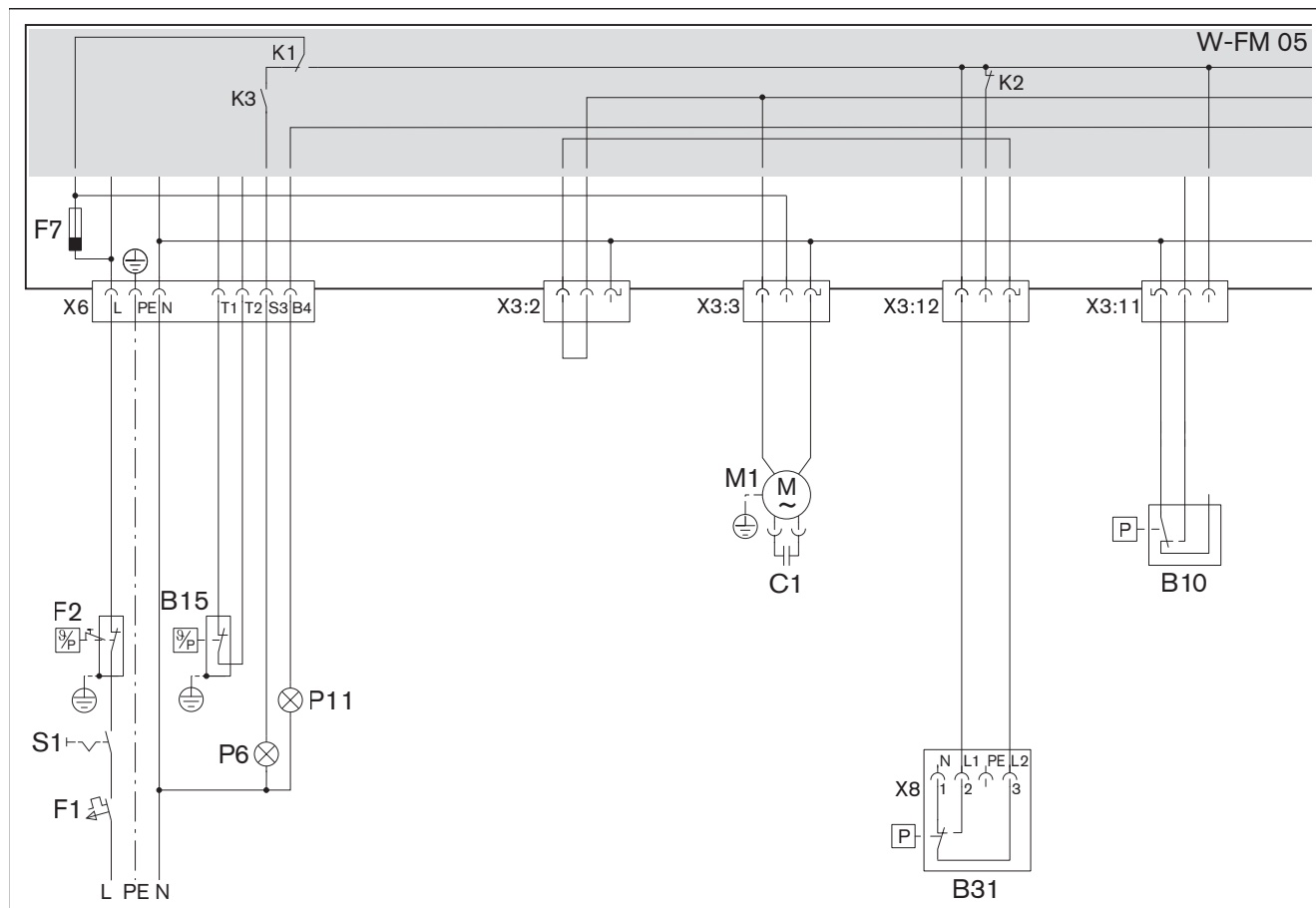

- C1 Motor capacitor
- F1 External fuse (max 16 AB)
- F2 Temperature or pressure limiter
- F7 Internal unit fuse (T6.3H, IEC 127-2/5)
- B10 Air pressure switch
- B31 Low gas pressure switch
- B15 Temperature or pressure regulator
- P6 Control lamp lockout (optional)
- P11 Control lamp operation (optional)
- M1 Burner motor
- S1 Operating switch

11 Technical documentation

11.2 Conversion table unit of pressure

Bar	Pascal			
	Pa	hPa	kPa	MPa
0.1 mbar	10	0.1	0,01	0.00001
1 mbar	100	1	0.1	0.0001
10 mbar	1 000	10	1	0.001
100 mbar	10 000	100	10	0,01
1 bar	100 000	1 000	100	0.1
10 bar	1 000 000	10 000	1 000	1

11.3 Appliance categories

Labelling of gas and dual fuel burners to EN 676

EN 676, "Forced draught burners for gaseous fuels", is used for the implementation of the basic requirements of the directive (EU) 2016/426.

EN 676 stipulate the following appliance categories for forced draught gas burners under Point 4.4.9:

I2R	for Natural Gas
I3R	for Liquid Petroleum Gas
II2R/3R	for Natural Gas / Liquid Petroleum Gas

The test gases listed under point 5.1.1, table 4 and the minimum test pressures determined and listed under point 5.1.2, table 5 are used to provide the evidence of service performance of the burner during type testing.

As -weishaupt- gas and dual fuel burners fulfil this requirement completely, the appliance category, as well as the test gases used with the permissible connection pressure range, are listed on the name plate when labelling the burner to point 6.2. This clearly defines the suitability of the burner for use with second or third family gases.

On the basis of a type test report to ISO 17025 from an accredited test centre, the EU Type Testing Certificate to Directive (EU) 2016/426 also quotes the appliance category, the supply pressure and the country of destination.

EN 437, "Test gases - test pressures - appliance categories", describes the interrelationships and the special national characteristics relating to this subject in detail.

The following tables give an overview of the interrelationships between the R Categories and the nationally used appliance categories with their types of gas and connection pressures.

11 Technical documentation

Alternative appliance category to I2R

Country of destination	Appliance category	Test gas	Connection pressure mbar
AL (Albania)	I2H	G 20	20
AT (Austria)	I2H	G 20	20
BA (Bosnia)	I2H	G 20	20
BE (Belgium)	I2E+, I2N, I2E(R)B	G 20 + G 25	Pressures 20 / 25
BG (Bulgaria)	I2H	G 20	20
BY (Belarus)			
CH (Switzerland)	I2H	G 20	20
CY (Cyprus)	I2H	G 20	20
CZ (Czech Republic)	I2H	G 20	20
DE (Germany)	I2ELL, I2E, I2L	G 20 / G 25	20
DK (Denmark)	I2H	G 20	20
EE (Estonia)	I2H	G 20	
ES (Spain)	I2H	G 20	20
FI (Finland)	I2H	G 20	20
FR (France)	I2Esi, I2E+, I2L	G 20 + G 25	Pressures 20 / 25
GB (United Kingdom)	I2H	G 20	20
GR (Greece)	I2H	G 20	20
HR (Croatia)	I2H	G 20	20
HU (Hungary)	I2H	G 20	20
IE (Ireland)	I2H	G 20	20
IS (Iceland)	I2H	G 20	20
IT (Italy)	I2H	G 20	20
LT (Lithuania)			
LU (Luxembourg)	I2E	G 20	20
LV (Latvia)			
MD (Moldova)	I2H	G 20	20
MK (Macedonia)	I2H	G 20	20
MT (Malta)	I2H	G 20	20
NL (The Netherlands)	I2L, I2EK	G 25	25
NO (Norway)	I2H	G 20	20
PL (Poland)	I2E	G 20 / GZ 410	20
PT (Portugal)	I2H	G 20	20
RO (Romania)	I2H	G 20	20
SE (Sweden)	I2H	G 20	20
SI (Slovenia)	I2H	G 20	20
SK (Slovakia)	I2H	G 20	20
SRB (Serbia)	I2H	G 20	20
TR (Turkey)	I2H	G 20	25
UA (Ukraine)	I2H	G 20	20

Alternative appliance category to I3R

Country of destination	Appliance category	Test gas	Connection pressure mbar
AL (Albania)	I3+, I3P, I3B	G 30 + G 31	Pressures 28 - 30 / 37
AT (Austria)	I3B/P, I3P	G 30 + G 31	50
BA (Bosnia)	I3B/P	G 30	30 (28-30)
BE (Belgium)	I3+, I3P, I3B, I3B/P	G 30 + G 31	Pressures 28 - 30 / 37
BG (Bulgaria)	I3+, I3P, I3B	G 30 + G 31	Pressures 28 - 30 / 37
BY (Belarus)			
CH (Switzerland)	I3B/P, I3+, I3P	G 30 + G 31	Pressures 28 - 30 / 37
CY (Cyprus)	I3B/P, I3+, I3P, I3B	G 30 + G 31	Pressures 28 - 30 / 37
CZ (Czech Republic)	I3B/P, I3+, I3P	G 30 + G 31	Pressures 28 - 30 / 37
DE (Germany)	I3B/P, I3P	G 30 + G 31	50
DK (Denmark)	I3B/P	G 30 + G 31	30 (28 - 30)
EE (Estonia)	I3B/P	G 30	
ES (Spain)	I3+, I3P, I3B	G 30 + G 31	Pressures 28 - 30 / 37
FI (Finland)	I3B/P	G 30 + G 31	30 (28 - 30)
FR (France)	I3+, I3P, I3B	G 30 G 31	Pressures 28 - 30 / 37 Pressures 112 / 148
GB (United Kingdom)	I3+, I3P, I3B	G 30 + G 31	Pressures 28 - 30 / 37
GR (Greece)	I3B/P, I3+, I3P, I3B	G 30 + G 31	Pressures 28 - 30 / 37
HR (Croatia)	I3B/P, I3P	G 30 + G31	50
HU (Hungary)	I3B/P	G 30 + G31	50
IE (Ireland)	I3+, I3P, I3B	G 30 + G 31	Pressures 28 - 30 / 37
IS (Iceland)	I3B/P		
IT (Italy)	I3B/P, I3+, I3P	G 30 + G 31	Pressures 28 - 30 / 37
LT (Lithuania)			
LU (Luxembourg)	I3B/P	G 30	
LV (Latvia)			
MD (Moldova)	I3+, I3P, I3B	G 30 + G 31	Pressures 28 - 30 / 37
MK (Macedonia)	I3+, I3P, I3B	G 30 + G 31	Pressures 28 - 30 / 37
MT (Malta)	I3+, I3P, I3B	G 30 + G 31	Pressures 28 - 30 / 37
NL (The Netherlands)	I3B/P, I3P	G 30 + G 31	30 (28 - 30)
NO (Norway)	I3B/P	G 30 + G 31	30 (28 - 30)
PL (Poland)	I3B/P	G 30	
PT (Portugal)	I3+, I3P, I3B	G 30 G 31	Pressures 28 - 30 / 37 Pressures 50 / 67
RO (Romania)	I3B/P	G 30	
SE (Sweden)	I3B/P	G 30 + G 31	30 (28 - 30)
SI (Slovenia)	I3B/P	G 30	30
SK (Slovakia)	I3B/P	G 30	30
SRB (Serbia)	I3B/P, I3P	G 30 + G 31	20
TR (Turkey)	I3B/P	G 30 + G 31	30
UA (Ukraine)	I3B/P, I3P	G 30 + G 31	50

11 Technical documentation

Alternative appliance category to II2R/3R

Country of destination	Appliance category	Test gas	Connection pressure mbar	Test gas	Connection pressure mbar
AL (Albania)	II2H3+, II2H3P	G 20	20	G 31	30
AT (Austria)	II2H3B/P, II2H3P	G 20	20	G 30 + G 31	50
BA (Bosnia)	II2H3B/P	G 20	20	G 30	
BE (Belgium)	II2E+3P, II2H3B/P	G 20, G 25	Pressures 20 / 25	G 30 + G 31	Pressures 28 - 30 / 37
BG (Bulgaria)	II2H3+, II2H3P	G 20	20	G 30 + G 31	Pressures 28 - 30 / 37
BY (Belarus)					
CH (Switzerland)	II1a2H, II2H3B/P, II2H3+, II2H3P	G 20	20	G 30 + G 31	Pressures 28 - 30 / 37
CY (Cyprus)	II2H3B/P, II2H3+, II2H3P	G20	20	G 30 + G 31	Pressures 28 - 30 / 37
CZ (Czech Republic)	II2H3B/P, II2H3+, II2H3P	G 20	20	G 30 + G 31	Pressures 28 - 30 / 37
DE (Germany)	II2ELL3B/P, II2E3B/P	G 20	20	G 30 + G 31	50
DK (Denmark)	II1a2H, II2H3B/P	G 20	G 20	G 30 + G 31	30
EE (Estonia)	II2H3B/P	G 20	20	G 30	30
ES (Spain)	II2H3P, II2H3+	G 20	20	G 30 + G 31	Pressures 28 - 30 / 37
FI (Finland)	II2H3B/P	G 20	20	G 30 + G 31	30 (28 - 30)
FR (France)	II2E+3+, II2E+3P, II2Esi3B/P	G 20	20	G 30 G 31	Pressures 28 - 30 / 37 Pressures 112 / 148
GB (United Kingdom)	II2H3+, II2H3P	G 20	20	G 30 + G 31	Pressures 28 - 30 / 37
GR (Greece)	II2H3B/P, II2H3+, II2H3P	G 20	20	G 30 + G 31	Pressures 28 - 30 / 37
HR (Croatia)	II2H3B/P	G 20	20	G 30 + G 31	30 (28-30)
HU (Hungary)	II2H3B/P	G 20	20	G 30 + G 31	
IE (Ireland)	II2H3+, II2H3P	G 20	20		
IS (Iceland)	II2H3B/P	G 20	20	G 30 + G 31	30 (28 - 30)
IT (Italy)	II1a2H, II2H3B/P, II2H3+, II2H3P	G 20	20	G 30 + G 31	Pressures 28 - 30 / 37
LT (Lithuania)					
LU (Luxembourg)	II2E3B/P	G 20	20	G 30 + G 31	
LV (Latvia)					
MD (Moldova)	II2H3+, II2H3P	G 20	20	G 30 + G 31	Pressures 30 / 37
MK (Macedonia)	II2H3+, II2H3P	G 20	20	G 30 + G 31	Pressures 30 / 37
MT (Malta)	II2H3+, II2H3P	G 20	20	G 30 + G 31	Pressures 30 / 37
NL (The Netherlands)	II2L3B/P, II2L3P, II2EK3B/P, II2EK3P	G 25	25	G 30 + G 31	30
NO (Norway)	II2H3B/P	G 20	20	G 30 + G 31	30 (28 - 30)
PL (Poland)	II2E3B/P	G 20	20	G 30 + G 31	30 (28 - 30)
PT (Portugal)	II2H3+, II2H3P	G 20	20	G 30 G 31	Pressures 28 - 30 / 37 Pressures 50 / 67
RO (Romania)	II2H3B/P	G 20	20	G 30 + G 31	30 (28 - 30)
SE (Sweden)	II1a2H, II2H3B/P	G 20	20	G 30 + G 31	30 (28 - 30)
SI (Slovenia)	II2H3B/P	G 20	20	G 30	30
SK (Slovakia)	II2H3B/P	G 20	20	G 30	30
SRB (Serbia)	II2H3B/P	G 20	20	G 30 + G 31	30 (28 - 30)
TR (Turkey)	II2H3B/P	G 20	25	G 30 + G 31	30 + 37
UA (Ukraine)	II2H3B/P	G 20	20	G 30 + G 31	30 (28 - 30)

12 Project planning

12.1 Continuous running fan or post-purge



Fire hazard due to failure of the combustion air fan

Failure of the combustion air fan (e.g. due to a power failure or defective motor) during operation with continuous running fan or increased post-purge may result in back radiation or hot flue gases flowing back into the burner housing. This could cause a fire.

If fail-safe continuous ventilation or post-purge is required, take appropriate measures, such as:

- ▶ installing compressed air flushing on site with:
 - sufficiently large compressed air tank,
 - normally open compressed air valve.

13 Spares

13 Spares

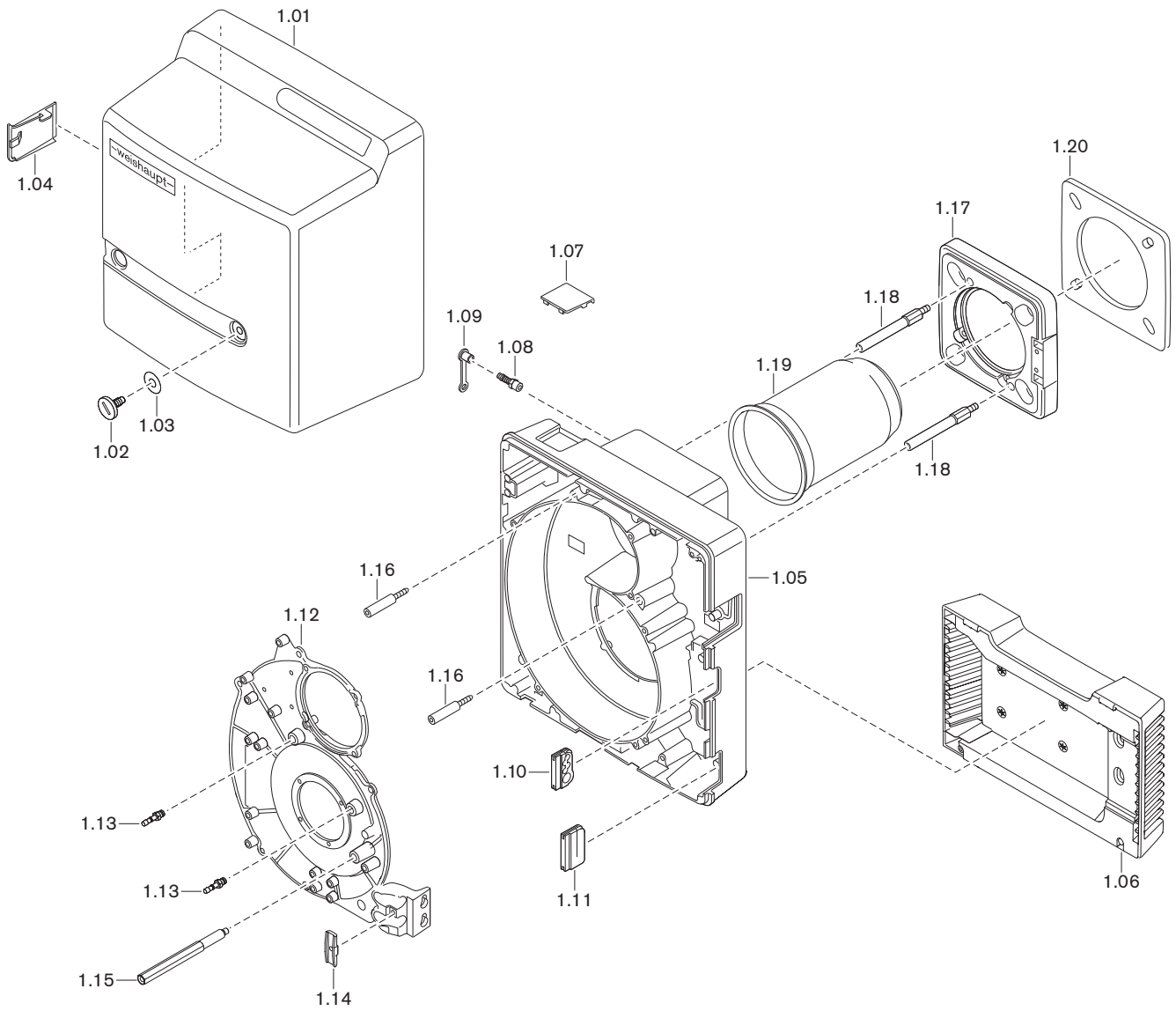

Pos.	Description	Order No.
1.01	Cover complete	241 110 01 112
1.02	Screw M8 x 15	142 013 01 157
1.03	Washer 7 x 18	430 016
1.04	Cover	241 210 01 127
1.05	Burner housing	241 110 01 307
1.06	Intake housing complete	241 110 01 082
	– Screw 4 x 30 Torx-Plus	409 325
1.07	View port on hours counter cover	241 210 01 197
1.08	Treaded socket R ¹ / ₈ GES6	453 017
1.09	Protective cap DN 6 SELF 50/2 CF	232 300 01 047
1.10	Grommet for connection cable	241 200 01 247
1.11	Grommet	241 400 01 177
1.12	Housing cover	241 110 01 317
1.13	Treaded socket R ¹ / ₈ GES4	453 004
1.14	Bracket for cable	241 400 01 367
1.15	Stay bolt cover	241 210 01 207
1.16	Screw M6 burner housing	241 110 01 297
1.17	Burner flange	241 110 01 057
	– Screw M8 x 30 DIN 912	402 517
	– Washer 8.4 DIN 433	430 504
1.18	Stay bolt for burner flange	241 050 01 187
1.19	Flame tube WG10/1-D	
	– Standard	232 110 14 122
	– extended by 100 mm*	230 110 14 132
	– extended by 200 mm*	230 110 14 142
	– extended by 300 mm*	230 110 14 152
1.20	Flange gasket	241 110 01 107

* Only in conjunction with combustion head extension.

13 Spares

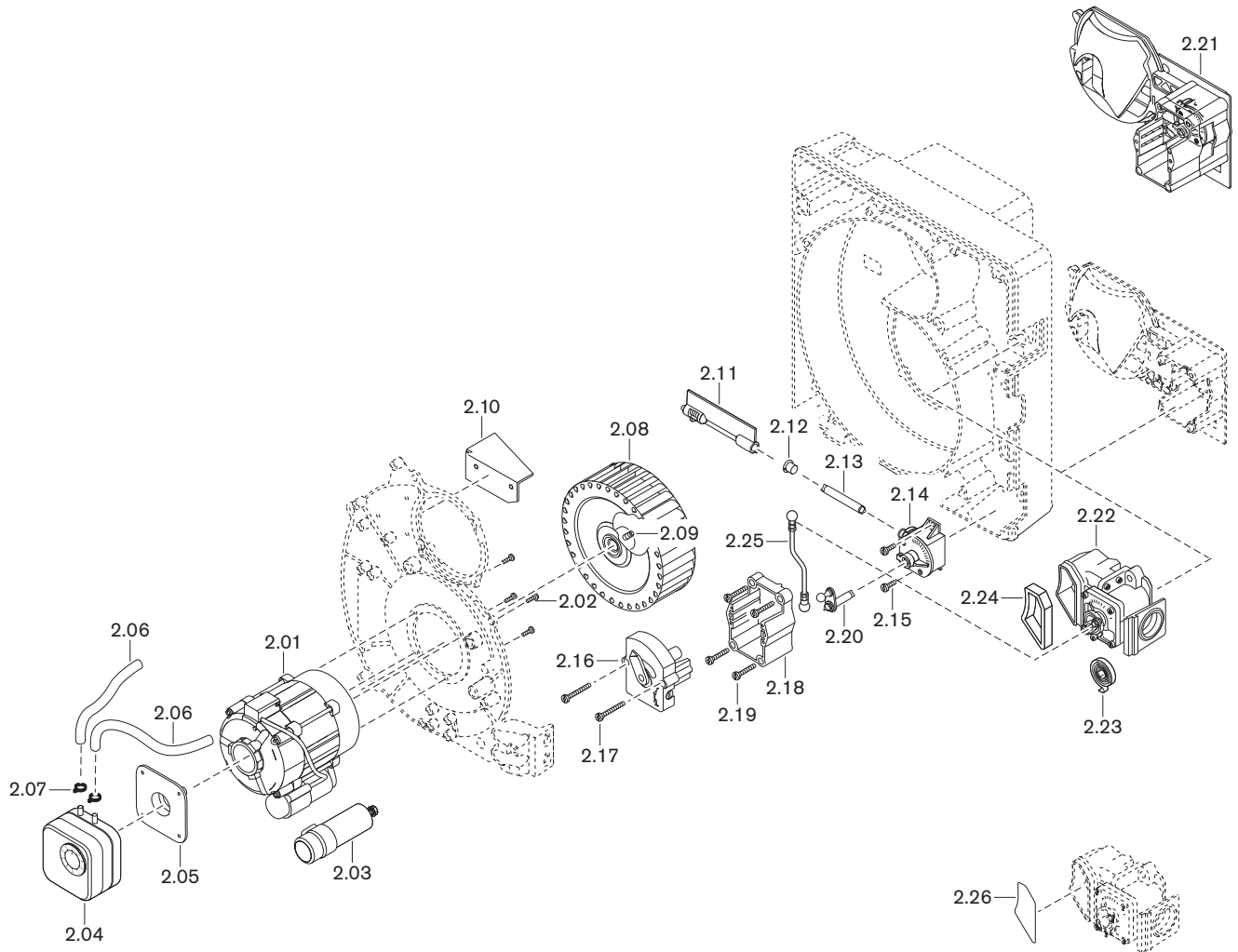

Pos.	Description	Order No.
2.01	Motor ECK03/H-2/1, 230 V / 50Hz 160 °C	652 113
2.02	Screw M4 x 10	409 323
2.03	Capacitor MKP 3/420	713 472
2.04	Pressure switch LGW 10 A2 1 - 10 mbar	691 370
2.05	Connection flange for LGW	605 243
2.06	Hose 4.0 x 1.75 190 mm	232 050 24 057
2.07	Hose clamp 7.5	790 218
2.08	Fan wheel TLR 157 x 47-L S1 50Hz	241 110 08 042
2.09	Grub screw M6x8 w. ann. cut. edge (Tuflok)	420 549
2.10	Air guide	232 110 01 017
2.11	Air damper complete	241 110 02 102
2.12	Bearing for air damper shaft	241 110 02 107
2.13	Shaft air damper - angle drive	241 210 02 057
2.14	Angle drive	241 110 02 062
2.15	Screw 4 x 12 Torx-Plus Remform	409 320
2.16	Manual adjustment	241 050 02 022
2.17	Screw 4 x 30 Torx-Plus Delta PT	409 325
2.18	Frame for actuator	241 210 02 037
2.19	Screw 4 x 30 Torx-Plus Delta PT	409 325
2.20	Lever complete	232 210 02 012
2.21	Air regulator W10D-Z spring 2	241 110 02 092
2.22	Gas butterfly valve	
	– Natural Gas	232 110 25 010
	– Liquid Petroleum Gas	233 110 25 010
2.23	Spring 2	241 400 02 167
2.24	Seal connection channel	232 110 25 087
2.25	Treaded rod complete	232 110 25 012
2.26	Blanking plate valve proving	232 210 26 172

13 Spares

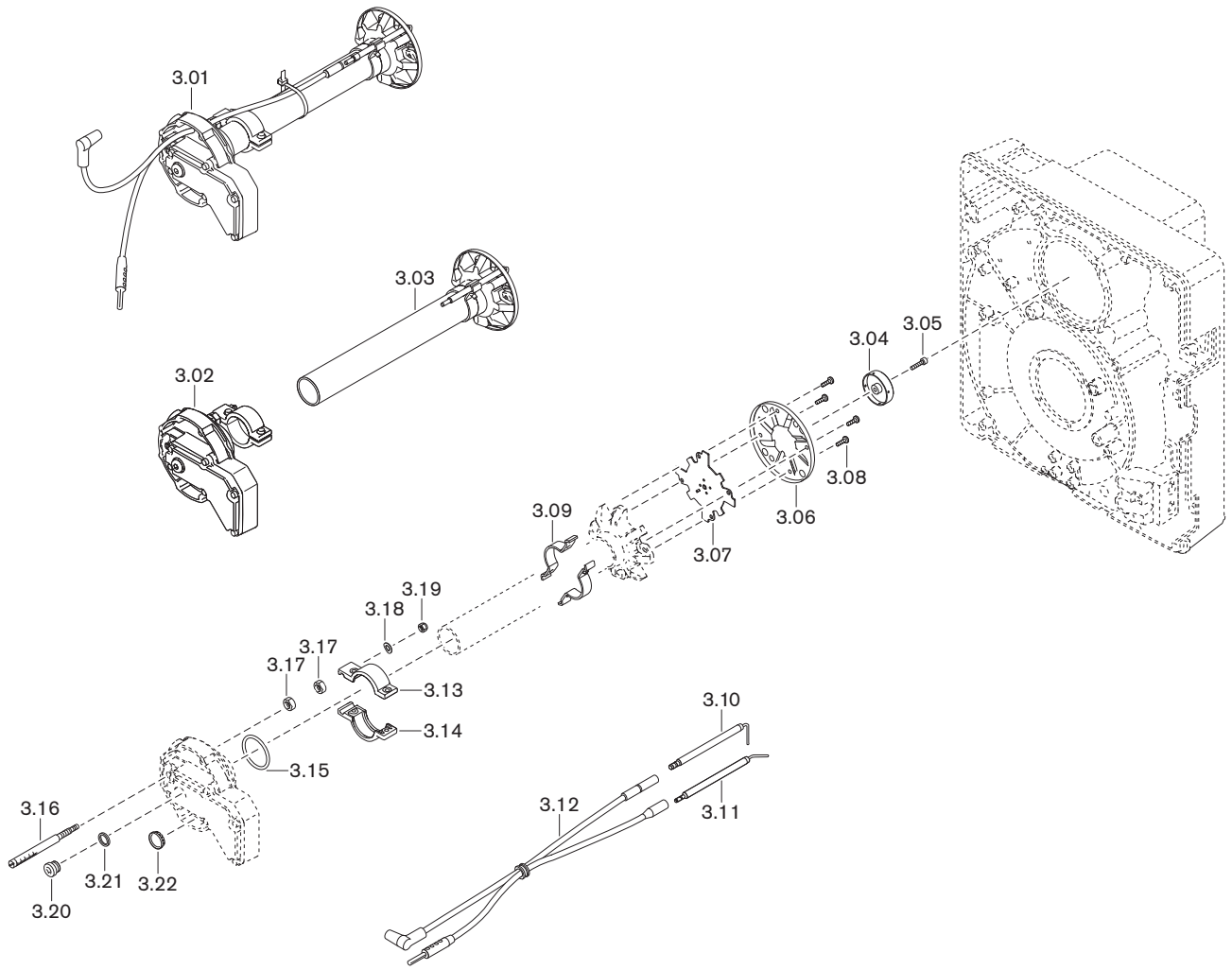

Pos.	Description	Order No.
3.01	Mixing head WG10N/... complete (Natural Gas)	
	– Standard	232 110 14 052
	– extended by 100 mm*	230 110 14 012
	– extended by 200 mm*	230 110 14 032
	– extended by 300 mm*	230 110 14 052
	Mixing head WG10F/... complete (LPG)	
	– Standard	233 110 14 012
	– extended by 100 mm*	230 110 14 072
	– extended by 200 mm*	230 110 14 092
	– extended by 300 mm*	230 110 14 112
3.02	Lock housing complete	232 110 14 022
3.03	Mixing tube WG10N/... complete (Natural Gas)	
	Ø internal 29 mm	
	– Standard	232 110 14 082
	– extended by 100 mm*	230 110 14 022
	– extended by 200 mm*	230 110 14 042
	– extended by 300 mm*	230 110 14 062
	Mixing tube WG10F/... complete (LPG)	
	Ø internal 12 mm	
	– Standard	233 110 14 022
	– extended by 100 mm*	230 110 14 082
	– extended by 200 mm*	230 110 14 102
	– extended by 300 mm*	230 110 14 122
3.04	Nozzle element	232 200 14 467
3.05	Screw M4 x 16 Torx-Plus 20IP	409 224
3.06	Diffuser 36 x 90	232 200 14 407
3.07	Nozzle insert	232 110 14 077
3.08	Screw M4 x 8 Torx-Plus 20IP	409 235
3.09	Bracket for electrodes	232 200 14 437
3.10	Ignition electrode isolator 6 x 80	232 200 14 217
3.11	Sensor electrode	232 100 14 207
3.12	Ignition and sensor cable	
	– 380 mm (Standard)	232 110 11 032
	– 480mm (for 100 mm extension)*	230 110 11 082
	– 600mm (for 200 mm extension)*	232 310 11 042
	– 640mm (for 300 mm extension)*	230 110 11 102
3.13	Carrier	232 200 14 037
3.14	Carrier	232 200 14 047
3.15	O ring 32 x 3 NBR70 ISO 3601	445 095
3.16	Adjusting screw	232 210 14 047
3.17	Hexagonal nut M8 left DIN 934 -8	411 413
3.18	Spring washer A5 DIN 137	431 613
3.19	Hexagonal nut M5 DIN 985	411 203
3.20	Screw G $\frac{1}{8}$ A DIN 908	409 004
3.21	Sealing ring 10 x 13.5 x 1.5 DIN 7603	441 033
3.22	View port glass	241 400 01 377

* Only in conjunction with combustion head extension.

13 Spares

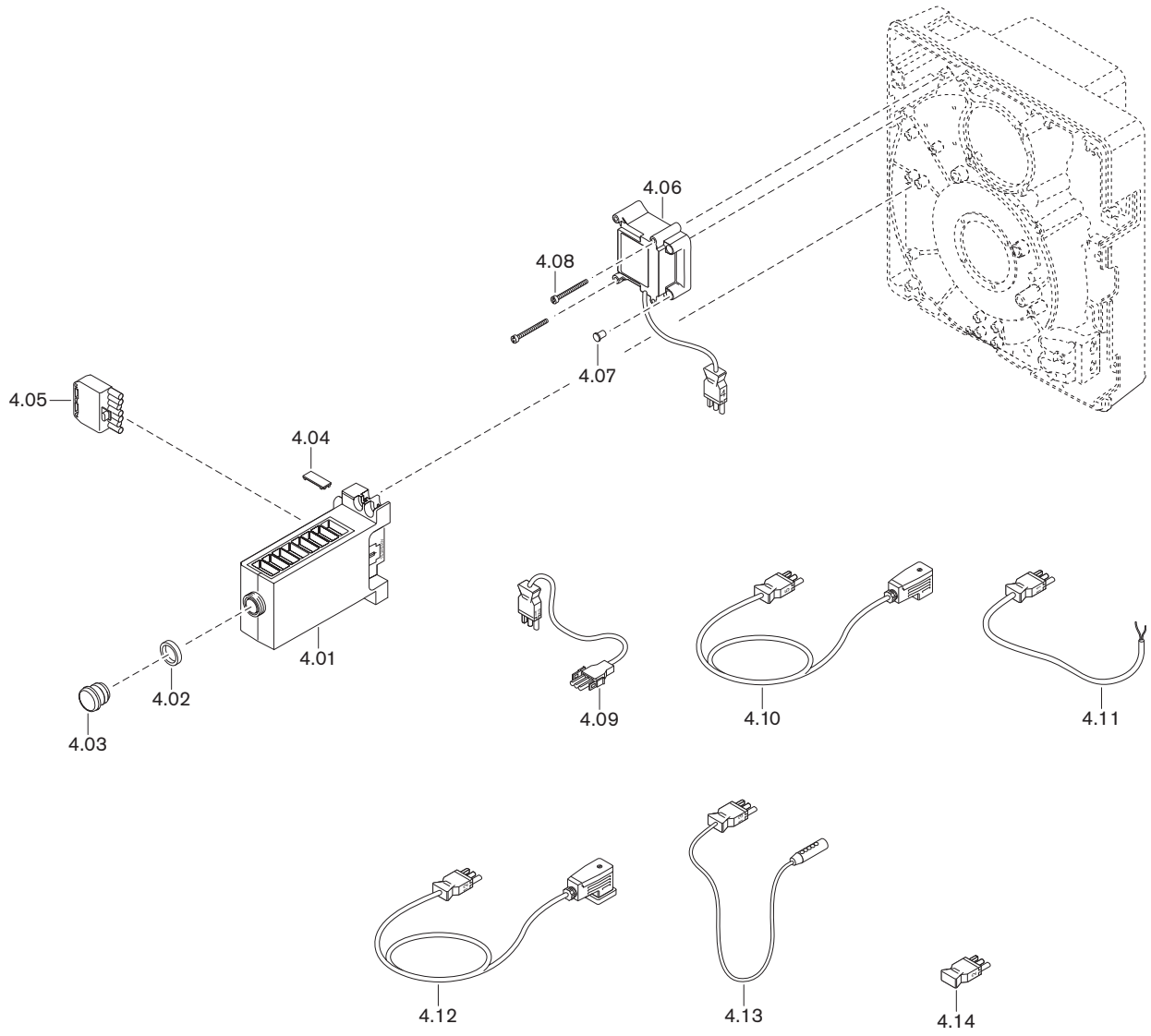

Pos.	Description	Order No.
4.01	Combustion manager W-FM05 230 V / 50/60 Hz	600 470
	– Micro fuse T6.3H, IEC 127-2/5	483 011 22 457
4.02	Adapter ring 22 x 4 for extension	600 358
4.03	Reset button extension AGK20.19	600 357
4.04	Cover clip AGK63	600 312
4.05	Plug unit ST18/7	716 549
4.06	Ignition unit type W-ZG01V 230 V 100 VA	603 229
4.07	Closing plug for ignition unit	603 224
4.08	Screw M4 x 42 Combi-Torx-Plus 20IP	409 260
4.09	Plug cable No. 3 fan motor	241 050 12 062
4.10	Plug cable No. 5 W-MF	232 110 12 052
4.11	Plug cable No. 11 air pressure switch	232 110 12 022
4.12	Plug cable No.12 gas pressure switch	232 050 12 022
4.13	Ionisation cable No. 13	232 310 12 012
4.14	Intermediate plug No. 2	240 200 12 012

13 Spares

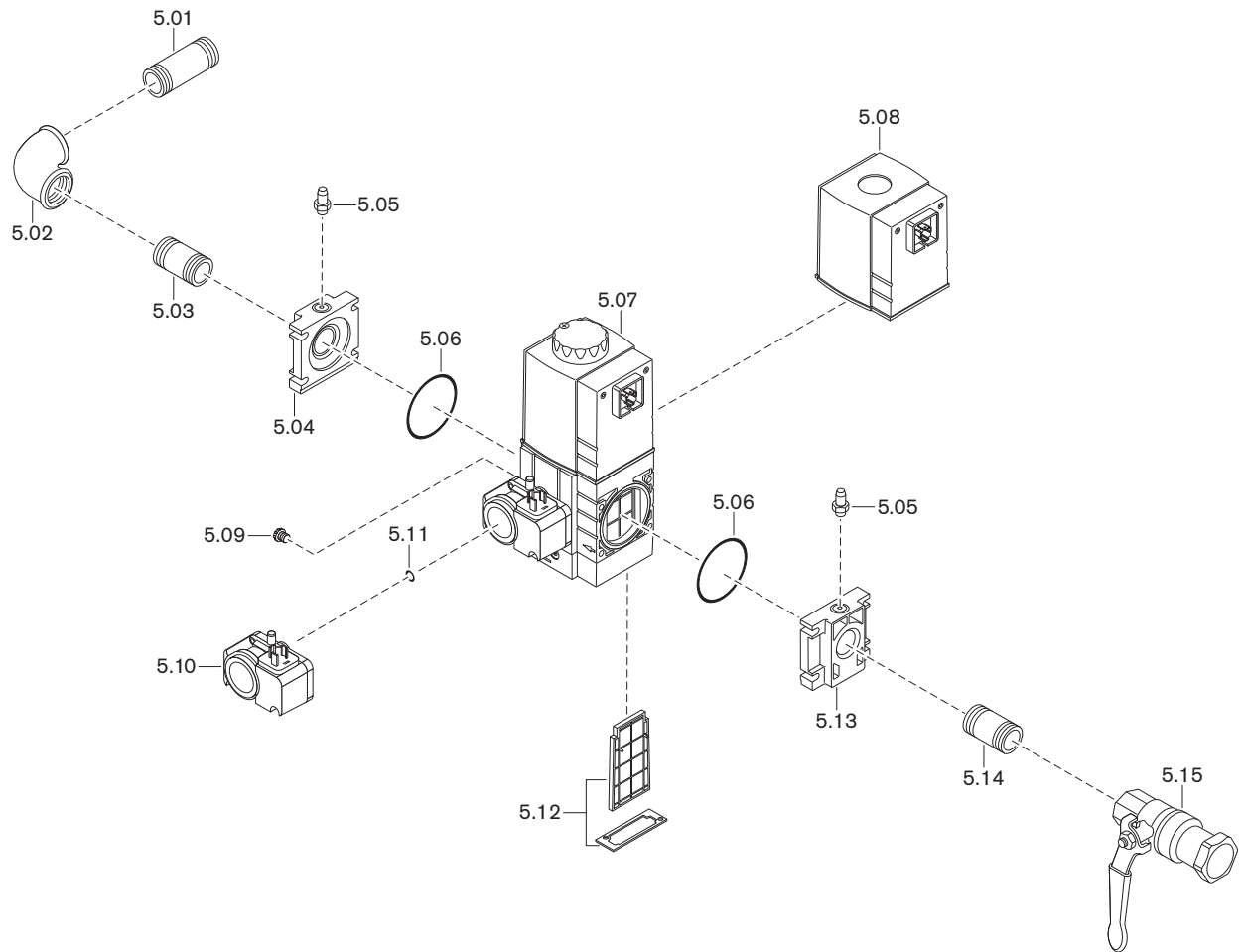

Pos.	Description	Order No.
5.01	Double nipple R $\frac{3}{4}$ x 80	139 000 26 787
5.02	Elbow A1- $\frac{3}{4}$ -Zn-A	453 143
5.03	Double nipple R $\frac{3}{4}$ x 50	139 000 26 727
5.04	Flange W-MF 507 Rp $\frac{3}{4}$	605 227
5.05	Pressure test nipple G $\frac{1}{8}$ A	453 001
5.06	O ring 57 x 3 W-MF 507	445 519
5.07	Multifunction ass. W-MF SLE 507 S22, 230V with gas pressure switch	605 326
5.08	Solenoid coil W-MF 507 No. 032P, 230 V	605 255
5.09	Breather plug with filter element G $\frac{1}{8}$	605 302
5.10	Pressure switch GW 50 A5/1, 5 ... 50 mbar	691 378
5.11	O ring 10.5 x 2.25	445 512
5.12	Filter insert with seal W-MF 507	605 253
5.13	Flange W-MF 507	
	– Rp $\frac{3}{4}$	605 227
	– Rp1	605 233
5.14	Double nipple	
	– R $\frac{3}{4}$ x 50	139 000 26 727
	– R1 x 50	139 000 26 177
5.15	Isolating valve with TAE	
	– 998 N G $\frac{3}{4}$ CE-TAS for Gas PN1	454 596
	– 998 N G1 CE-TAS for Gas PN 1	454 597
	Isolating valve without TAE	
	– 984 D Rp $\frac{3}{4}$ PN 40/MOP5	454 660
	– 984 D Rp1 PN 40/MOP5	454 661

14 Notes

14 Notes

15 Key word index

A	
Air damper	11, 38, 39, 57, 58, 60
Air damper setting	38
Air number	47
Air pressure	48
Air pressure switch.....	11, 45
Air regulator.....	60
Ambient conditions.....	16
Ammeter.....	30
Angle drive.....	58
Aperture	21, 22
Appliance category.....	73
Approval data.....	16
B	
Bar	72
Basic setting	53
Basic settings.....	38
Boiler room.....	7
Booming.....	69
Breaks in operation.....	49
Breather plug	61
Burner motor.....	13, 56
C	
Calorific value	36
Capacity	18
Capacity graph	18
CO content	47
Coil.....	61
Combustion air	7
Combustion chamber pressure.....	18
Combustion control.....	47
Combustion head	18
Combustion head extension.....	21
Combustion heat rating.....	18, 38
Combustion Manager	13, 28
Commissioning.....	29
Condensate.....	8
Connection pressure	23, 31, 36
Consumption.....	16
Conversion factor	48
Conversion table.....	72
Current measuring device.....	30
D	
Default settings	38
Design lifespan.....	7, 50
Diffuser	11, 38, 39
Diffuser setting	38
Dimensions.....	19
Display.....	28
Disposal	8
Double gas valve.....	12, 23
Drilling diagram.....	21
Ducted air intake	7, 18
E	
Electrical connection.....	27
Electrical data	16
Electrode.....	54
Electrostatic discharge.....	8
Emission.....	17
Emission class.....	17
Error code.....	65
Error codes.....	66, 68
Errors	66
ESD protection measures.....	8
Excess air.....	47
F	
Fabrication number.....	10
Fan motor.....	56
Fan pressure	30, 40
Fan wheel.....	11, 56
Fault	64, 69
Fault history	65
Faults	68
Filter	12, 62
Filter insert	62
Flame signal	13, 30
Flame tube.....	21
Flashing codes	66, 68
Flue gas losses.....	47
Flue gas measurement.....	47
Flue gas temperature	47
Fuel.....	16
Fuel release	14
Fuse	63
Fusing.....	16
G	
Gas butterfly valve	12, 39
Gas connection pressure.....	23, 31
Gas family	73
Gas filter.....	12, 62
Gas isolating valve.....	12, 20
Gas pressure switch	26, 44
Gas setting pressure.....	36
Gas supply	23
Gas temperature	48
Gas throughput	48
Gas valve train	20, 22, 23, 24, 36
Guarantee.....	6
H	
Heat exchanger	21
High gas pressure switch	12, 44
Hours counter.....	71
Housing cover.....	55
Humidity	16
I	
Ignition	14
Ignition electrode	54
Ignition unit	13
Illuminated push button	28, 64, 65
Indicating bolt	39

Initialisation time 15
 Installation 21, 22
 Installation elevation 16, 18
 Installation location 21
 Installation position 23
 Intake housing 60
 Ionisation current 30
 Ionisation electrode 13, 54
 Isolating valve 12, 20

L

Liability 6
 Lifespan 7, 50
 Lockout 64, 66, 68
 Low gas pressure switch 12
 Low gas programme 12

M

Mains voltage 16
 Maintenance position 55
 mbar 72
 Measuring device 30
 Mixing head 11, 38, 52, 53
 Mixing pressure 30, 40
 Monitoring current 30
 Motor 13, 56
 Multifunction assembly 12

N

Name plate 10
 Noise 69
 Nominal diameter 36

O

Operating hours counter 71
 Operating problems 69
 Operating volume 48

P

Pa 72
 Pascal 72
 Personal protective equipment 7
 Plug assignment 70
 Post-purge 14
 Post-purge time 15
 PPE 7
 Pre-ignition time 15
 Pre-purge 14
 Pre-purge time 15
 Pressure measuring device 30
 Pressure regulator 12, 23
 Pressure switch 11, 44, 45
 Pressure switches 41
 Program sequence 14
 Protective equipment 7
 Pulsating 69

R

Refractory 21
 Remote reset 27
 Reset 65
 Reset button 28

S

Safety measures 7
 Safety time 14, 15
 Sequence diagram 14
 Serial number 10
 Service 50
 Service contract 50
 Service interval 50
 Service plan 51
 Service position 55
 Setting dimensions 53
 Setting pressure 36
 Setting screw 53
 Shutdown 49
 Shutdown time 49
 Signal lamp 28
 Smell of gas 7
 Solenoid coil 61
 Sound 17
 Sound power level 17
 Sound power levels 17
 Sound pressure level 17
 Soundness test 32
 Spares 79
 Stability problems 69
 Standard volume 48
 Standards 16
 Storage 16

T

Temperature 16
 Test points 34
 Test pressure 32
 Transport 16
 Troubleshooting 69
 Type key 9
 Type of gas 16, 73

U

Unit 72
 Unit fuse 63
 Unit of pressure 72

V

Valve train 24
 Voltage supply 16

W

Weight 20
 Wiring diagram 70

The complete program: Reliable technology and prompt, professional service

	<p>W Burners up to 570 kW</p> <p>The compact burners, proven millions of times over, are economical and reliable. Available as gas, oil and dual fuel burners for domestic and commercial applications.</p> <p>The purflam® burner version with special mixing head gives almost soot-free combustion of oil with greatly reduced NOx emissions.</p>	<p>Wall-hung condensing boilers for gas up to 240 kW</p> <p>The wall-hung condensing boilers WTC-GW have been developed to meet the highest demands in ease of operation and efficiency. Modulating operation means these units operate quietly and economically.</p>	
	<p>monarch® WM Burners and Industrial Burners up to 11,700 kW</p> <p>These legendary industrial burners are durable and versatile. Numerous variations of oil, gas and dual fuel burners meet a wide range of applications and capacity requirements.</p>	<p>Floor-standing condensing boilers for oil and gas up to 1,200 kW</p> <p>The floor-standing condensing boilers WTC-GB (up to 300 kW) and WTC-OB (up to 45 kW) are efficient, low in pollutants and versatile in use. Even the largest capacities can be covered by cascading up to four gas condensing boilers.</p>	
	<p>WKmono 80 Burners up to 17,000 kW</p> <p>The WKmono 80 burners are the most powerful monoblock burners from Weishaupt. They are available as oil, gas or dual fuel burners and are designed for tough industrial application.</p>	<p>Solar systems</p> <p>The stylish flat-plate collectors are the ideal complement for any Weishaupt heating system. They are suitable for solar water heating and for combined heating support. With versions for on-roof, in-roof and flat roof installations, solar energy can be utilised on almost any roof.</p>	
	<p>WK Burners up to 32,000 kW</p> <p>These industrial burners of modular construction are adaptable, robust and powerful. Even on the toughest industrial applications these oil, gas and dual fuel burners operate reliably.</p>	<p>Water heaters/Energy storage</p> <p>The diverse program of potable water and energy storage for various heat sources includes storage volumes of 70 to 3,000 litres. In order to minimize storage losses, potable water cylinders from 140 to 500 litres are available with highly efficient insulation using vacuum insulation panels.</p>	
	<p>MCR Technology / Building Automation from Neuberger</p> <p>From control panels to complete building management systems - at Weishaupt you can find the entire spectrum of modern control technology. Future orientated, economical and flexible.</p>	<p>Heat pumps up to 180 kW</p> <p>The heat pump range offers solutions for the utilisation of heat from the air, the soil or ground water. Some systems are also suitable for cooling buildings.</p>	
	<p>Service</p> <p>Weishaupt customers can be assured that specialist knowledge and tools are available whenever they are needed. Our service engineers are fully qualified and have extensive product knowledge, be it for burners, heat pumps, condensing boilers or solar collectors.</p>	<p>Geothermal probe drilling</p> <p>With its daughter company, BauGrund Süd, Weishaupt also offers geothermal probe and well drilling. With the experience of more than 10,000 systems and more than 2 million meters of drilling, BauGrund Süd offers a comprehensive service program.</p>	