

–weishaupt–

manual

Installation and operating instruction

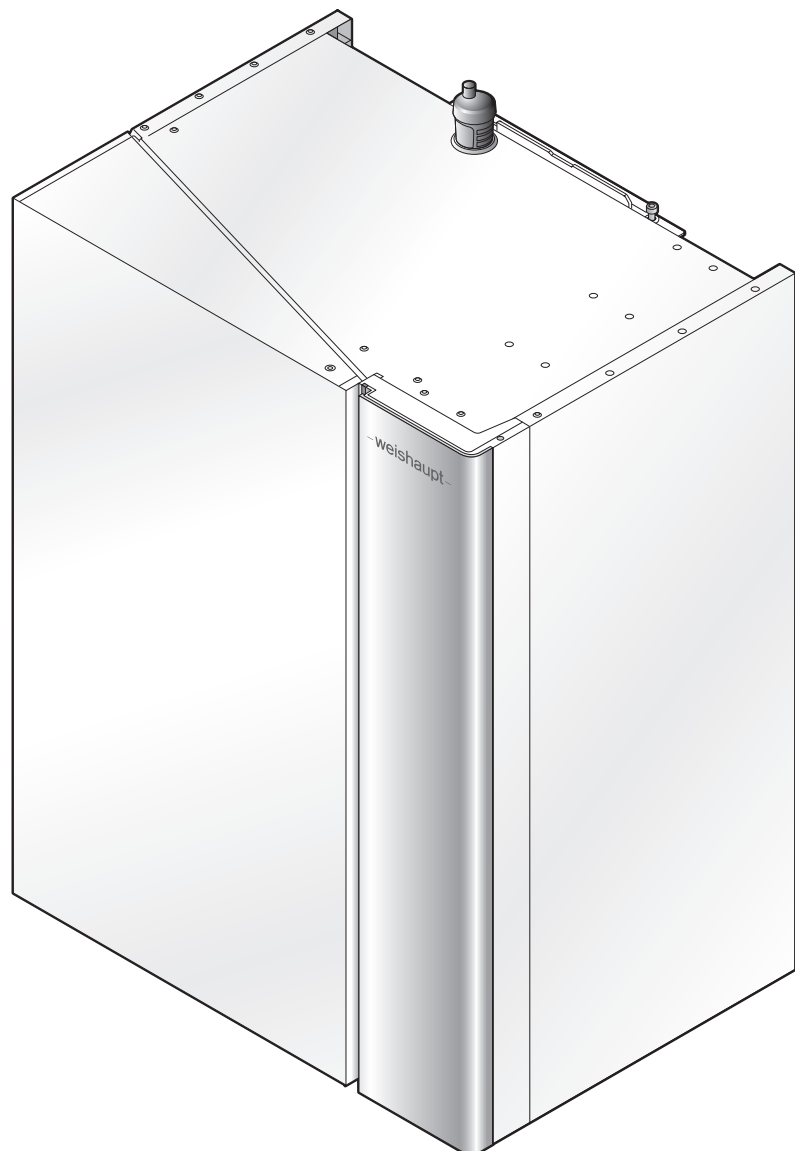

EU conformity certification

Language 02

Product description **Hydraulic unit**

Type **WWP LS 8-B R-E HE**
WWP LS 10-B R-E HE
WWP LS 13-B R-E HE
WWP LS 10-B R HE
WWP LS 13-B R HE
WWP LS 16-B R HE

Manufacturer **Max Weishaupt GmbH**

Address **Max-Weishaupt-Straße 14, DE-88475 Schwendi**

The sole responsibility for issuing this conformity declaration lies with the manufacturer.
The content of the statement described above complies with the relevant harmonisation legislation of the European Union:

EMC 2014/30/EU
Standards applied: EN 61000-6-1:2007, EN 61000-6-3:2007

LVD 2014/35/EU
Standards applied: EN 60335-1:2010, EN 60335-2-40:2010

ELD 2010/30/EU

EDD 2009/125/EC

Schwendi, 05.04.2017

Signed for and on behalf of:

MAX WEISHAUPT GMBH

ppa.



Dr. Schloen
Manager research and Development

ppa.



Denking
Manager Production and Quality Management

| | | |
|----------|--|-----------|
| 1 | User instructions | 6 |
| 1.1 | Target group | 6 |
| 1.2 | Symbols | 6 |
| 1.3 | Guarantee and Liability | 7 |
| 2 | Safety | 8 |
| 2.1 | Designated application | 8 |
| 2.2 | Procedure when refrigerant leaks | 8 |
| 2.3 | Safety measures | 8 |
| 2.3.1 | Normal operation | 8 |
| 2.3.2 | Electrical connection | 8 |
| 2.3.3 | Refrigeration circuit | 9 |
| 2.4 | Disposal | 9 |
| 3 | Product description | 10 |
| 3.1 | Type key | 10 |
| 3.2 | Serial number | 10 |
| 3.3 | Function | 11 |
| 3.4 | Technical data | 14 |
| 3.4.1 | Approval data | 14 |
| 3.4.2 | Electrical data | 14 |
| 3.4.3 | Installation location | 15 |
| 3.4.4 | Ambient conditions | 15 |
| 3.4.5 | Rating | 15 |
| 3.4.5.1 | Heating capacity (EN 14511) | 15 |
| 3.4.5.2 | Cooling capacity (EN 14511) | 17 |
| 3.4.5.3 | Resulting supply pressure | 18 |
| 3.4.6 | Operating pressure | 19 |
| 3.4.7 | Contents | 19 |
| 3.4.8 | Weight | 19 |
| 3.4.9 | Dimensions | 20 |
| 4 | Installation | 21 |
| 4.1 | Installation conditions | 21 |
| 4.2 | Remove front panel | 21 |
| 4.3 | Mounting the wall bracket | 22 |
| 4.4 | Hanging and aligning the unit | 22 |
| 5 | Installation | 23 |
| 5.1 | Requirements for the heating water | 23 |
| 5.2 | Hydraulic connection | 24 |
| 5.3 | Refrigerant pipework | 25 |
| 5.4 | Condensate connection | 26 |
| 5.5 | Electrical connection | 27 |
| 5.5.1 | Wiring diagram | 29 |
| 6 | Operation | 31 |
| 6.1 | Operational display | 31 |
| 6.2 | Display and operating unit | 32 |
| 6.3 | Display | 33 |

| | | |
|----------|-------------------------------------|-----------|
| 6.4 | Favourites level | 34 |
| 6.4.1 | Set room setpoint temperature | 35 |
| 6.4.2 | Set DHW setpoint temperature | 36 |
| 6.4.3 | Set time program | 37 |
| 6.5 | User level | 39 |
| 6.6 | Expert level | 40 |
| 6.7 | Menu structure | 41 |
| 6.7.1 | Info | 41 |
| 6.7.1.1 | Heating circuit | 41 |
| 6.7.1.2 | Heat pump | 42 |
| 6.7.1.3 | Second heat exchanger | 43 |
| 6.7.1.4 | Statistic | 44 |
| 6.7.2 | System operating mode | 45 |
| 6.7.3 | Heating circuit | 46 |
| 6.7.3.1 | Party/Pause | 46 |
| 6.7.3.2 | Room setpoint temperature | 47 |
| 6.7.3.3 | Heating characteristic curve | 47 |
| 6.7.3.4 | Settings | 48 |
| 6.7.3.5 | Summer/Winter change-over | 49 |
| 6.7.3.6 | Time programs | 49 |
| 6.7.3.7 | Cooling | 50 |
| 6.7.3.8 | Reset | 51 |
| 6.7.4 | Domestic hot water | 52 |
| 6.7.4.1 | Time programs | 52 |
| 6.7.4.2 | DHW Push | 52 |
| 6.7.4.3 | DHW setpoint temperature | 52 |
| 6.7.4.4 | Legionella protection | 53 |
| 6.7.4.5 | Settings | 53 |
| 6.7.4.6 | Flange heating | 54 |
| 6.7.4.7 | Reset | 54 |
| 6.7.5 | Heat pump | 55 |
| 6.7.5.1 | Service | 55 |
| 6.7.5.2 | Settings | 56 |
| 6.7.5.3 | Throughput | 57 |
| 6.7.5.4 | Modulation | 57 |
| 6.7.5.5 | Pump (circulation pump) | 58 |
| 6.7.5.6 | Heating | 58 |
| 6.7.5.7 | Cooling | 58 |
| 6.7.5.8 | Domestic hot water | 59 |
| 6.7.5.9 | Reset | 59 |
| 6.7.5.10 | Hibernation program | 59 |
| 6.7.6 | Second heat exchanger | 60 |
| 6.7.7 | Variable output | 61 |
| 6.7.8 | Settings | 62 |
| 6.7.9 | Fault memory | 62 |
| 6.7.9.1 | Fault memory | 62 |
| 7 | Commissioning | 63 |
| 7.1 | Prerequisite | 63 |

| | | |
|-----------|---|-----------|
| 7.2 | Steps for commissioning | 64 |
| 8 | Shutdown | 69 |
| 9 | Servicing | 70 |
| 9.1 | Notes on servicing | 70 |
| 9.2 | Service work | 72 |
| 9.3 | Removing and refitting expansion vessel | 73 |
| 9.4 | Replace safety valve | 75 |
| 9.5 | Rinse sludge separator | 76 |
| 10 | Troubleshooting | 77 |
| 10.1 | Procedures for fault conditions | 77 |
| 10.2 | Fault codes | 79 |
| 11 | Technical documentation | 81 |
| 11.1 | Sensor variables | 81 |
| 11.2 | Smart-Grid | 82 |
| 12 | Project planning | 83 |
| 12.1 | Expansion vessel and system pressure | 83 |
| 13 | Key word index | 84 |

1 User instructions

1 User instructions

This manual forms part of the equipment and must be kept on site.

Carefully read the manual prior to working on the unit.

It is supplemented by the installation and operating instructions for the outdoor unit.

1.1 Target group







The manual is intended for the operator and qualified personnel. They should be observed by all personnel working with the unit.

Work on the unit must only be carried out by personnel who have the relevant training and instruction.

In accordance with EN 60335-1 the following requirements apply

This appliance can be used by children 8 years and above as well as by persons with limited physical, sensory or mental capacities or lack of experience and knowledge, provided they are supervised or have been instructed regarding the safe use of the appliance and understand the resulting danger. Children must not play with the appliance. Cleaning and operator maintenance must not be carried out by children without supervision.

1.2 Symbols

| | |
|---|---|
|  DANGER | Immediate danger with high risk. Non observance can lead to serious injury or death. |
|  WARNING | Danger with medium risk. Non observance can lead to environmental damage, serious injury or death. |
|  CAUTION | Danger with low risk. Non observance can cause damage to the equipment and injury to personnel. |
|  | Important information |
|  | Requires direct action |
|  | Result after an action |
|  | Itemisation |
| ... | Range of values |

1 User instructions

1.3 Guarantee and Liability

Guarantee and liability claims for personal and equipment damage are excluded, if they can be attributed to one or more of the following causes:

- non approved application,
- non-observance of the manual,
- operation with faulty safety equipment,
- continual operation despite a fault,
- improper installation, commissioning, operation and service,
- repairs, which have been carried out incorrectly,
- the use of non original Weishaupt parts,
- force majeure,
- unauthorised modifications made to the unit,
- the installation of additional components, which have not been tested with the unit,
- unsuitable media,
- defects in the inlet lines.

2 Safety

2 Safety

2.1 Designated application

The hydraulic unit, in conjunction with the outdoor unit, is suitable for:

- heating heating water to VDI 2035,
- mono-energetic and bivalent operation up to -20 °C external temperature,
- room cooling,
- heating DHW to "TrinkwV".

The unit is only suitable for domestic application. It is not suitable for use in industrial processes.

Improper use could:

- endanger the health and safety of the user or third parties,
- cause damage to the unit or other material assets.

2.2 Procedure when refrigerant leaks

Leaking refrigerant collects at the base of the unit. Inhalation may cause suffocation, and even death.

Avoid open flames and spark generation.

- ▶ Use protection provided on site to isolate the outdoor unit/system from the mains supply.
- ▶ Open doors and windows.
- ▶ Leave the room.
- ▶ Warn all tenants.
- ▶ Notify Weishaupt service department or refrigeration engineer.

2.3 Safety measures

Safety relevant fault conditions must be eliminated immediately.

2.3.1 Normal operation

- All labels on the unit must be kept in a legible condition.
- Stipulated settings, service and inspection work should be carried out at regular intervals.
- Only operate the unit with its cover closed.

2.3.2 Electrical connection

For work carried out on live components:

- Observe the accident prevention instructions DGUV Regulation 3 and adhere to local directives,
- tools in accordance with EN 60900 should be used.

2 Safety

2.3.3 Refrigeration circuit

- Only a competent person in accordance with §5 ChemKlimaSchutzV (Carbon Chemical Regulation) may install, alter and service a refrigeration circuit.
- Observe BG regulation "Operating works material" (BGR 500).
- Observe EU Regulation No. 517/2014 on fluorinated greenhouse gases (F-Gas regulation).
- Wear suitable safety glasses and gloves suitable for refrigerants when handling refrigerant.
- Carry out leakage test with leak detecting device after each service and fault rectification.

2.4 Disposal

Dispose of all materials and components in a safe and environmentally friendly way at an authorised location. Observe local regulations.

Dispose of refrigerant in the correct manner.

3 Product description

3 Product description

3.1 Type key

Example: WWP LS 10-B R-E HE

| | |
|-----|-----------------------------|
| WWP | Series: Weishaupt heat pump |
| L | Heat source: Air |
| S | Design type: split |
| 10 | Ratings size: 10 |
| B | Construction |
| R | Version: reversible |
| E | Version: single phase |
| HE | Hydraulic unit |

3.2 Serial number

The serial number on the name plate identifies the product. This is required by Weishaupt's customer service department.

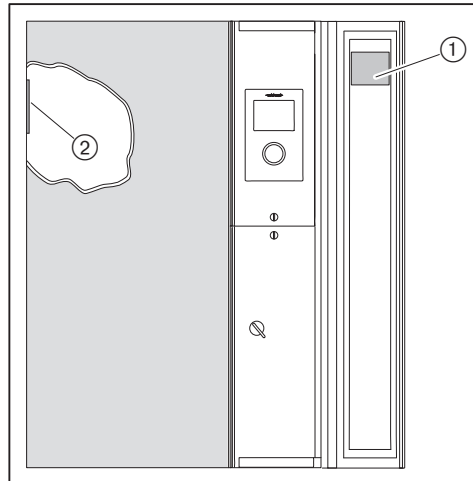

- ① Additional name plate
- ② Name plate

Ser.No. _____

3 Product description

3.3 Function

The hydraulic unit transfers the heat supplied by the outdoor unit to the heating circuit.

An internal circuit reversal in the outdoor unit allows the hydraulic unit to be used for cooling.

Overview water and refrigerant carrying parts

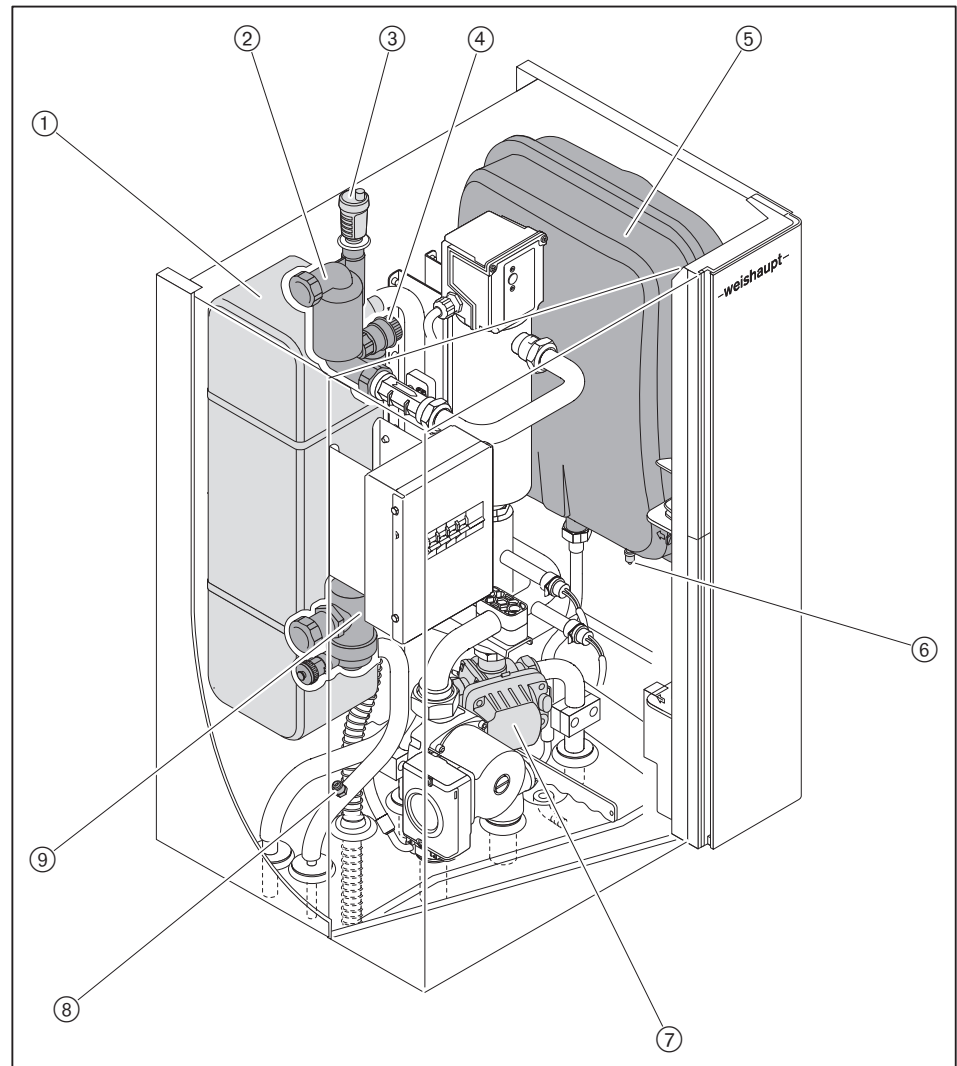

- ① Condenser
- ② Air separator
- ③ Quick action vent valve
- ④ Safety valve
- ⑤ Expansion vessel 18 l / 0.75 bar
- ⑥ Filler valve expansion vessel
- ⑦ Three way valve
- ⑧ Service connection 3/8" pipe (liquid pipe)
- ⑨ Sludge separator

3 Product description

Overview electrical parts

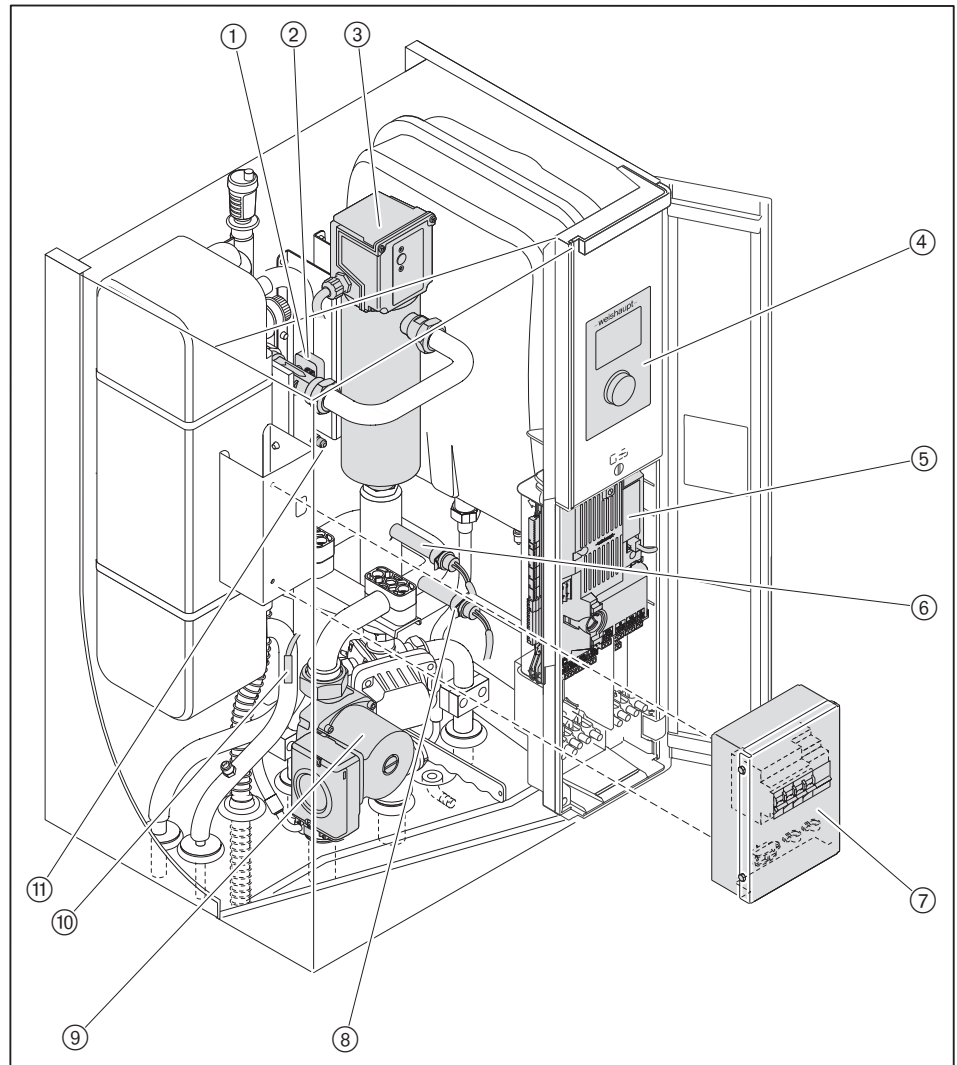

- ① Flow sensor LWT (B4) requirement for HP
- ② Flow sensor (B10)
- ③ Electric heating
- ④ Display and operating unit (system device)
- ⑤ Device electronic with electrical connection and device fuse
- ⑥ Electric heating flow sensor (B7)
- ⑦ Electrical panel electric heating
- ⑧ Return flow sensor EWT (B9)
- ⑨ Circulation pump
- ⑩ Internal refrigerant sensor (B8)
- ⑪ Internal heat exchanger pressure sensor (B12)

3 Product description

Condenser

The refrigerant releases the recovered energy to the heating water via the condenser.

Circulation pump

The circulation pump delivers the heating water to the radiator, underfloor heating or the storage.

Three way valve

The three way valve controls the flow of the heating water. It switches between heating mode and hot water mode.

Sludge separator

The sludge separator filters impurities from the heating water and thus protects the condenser.

Flow sensor

The flow sensor monitors the minimum flow in the heating circuit.

Electric heating

If the external temperature is low or if there is a fault, the electric heating can support the heat pump.

3 Product description

3.4 Technical data

3.4.1 Approval data

| | |
|-------------------|--|
| EHPA, Germany | has been applied for |
| EHPA, Switzerland | has been applied for |
| Basic standards | EN 60335-2-40 EN 61000-6-1 EN 61000-6-3 EN 14511-1 EN 14511-2 EN 14511-3 EN 14825 Additional standards, see EU conformity certification [page 2]. |

3.4.2 Electrical data

| | 8-B R-E HE | 10-B R-E HE | 13-B R-E HE |
|--|---|---|---|
| Mains voltage / mains frequency electric heating | 230 V, 1~, N, 50 Hz optional ⁽¹⁾ : 400 V, 3~, N, 50 Hz | 230 V, 1~, N, 50 Hz optional ⁽¹⁾ : 400 V, 3~, N, 50 Hz | 230 V, 1~, N, 50 Hz optional ⁽¹⁾ : 400 V, 3~, N, 50 Hz |
| Mains voltage/mains frequency hydraulic unit | 230 V, 1~, N, 50 Hz | 230 V, 1~, N, 50 Hz | 230 V, 1~, N, 50 Hz |
| Consumption of electric heating | 2 x 3500 W | 2 x 3500 W | 2 x 3500 W |
| Heating circuit pump consumption | 5 ... 87 W | 5 ... 87 W | 3 ... 140 W |
| Control power consumption in total | max 89 W | max 89 W | max 142 W |
| Regulation power consumption standby | 3 W | 3 W | 3 W |
| Type of protection | IP 40 | IP 40 | IP 40 |

⁽¹⁾ When using the second stage of the electric heating.

| | 10-B R HE | 13-B R HE | 16-B R HE |
|--|---|---|---|
| Mains voltage / mains frequency electric heating | 230 V, 1~, N, 50 Hz optional ⁽¹⁾ : 400 V, 3~, N, 50 Hz | 230 V, 1~, N, 50 Hz optional ⁽¹⁾ : 400 V, 3~, N, 50 Hz | 230 V, 1~, N, 50 Hz optional ⁽¹⁾ : 400 V, 3~, N, 50 Hz |
| Mains voltage/mains frequency hydraulic unit | 230 V, 1~, N, 50 Hz | 230 V, 1~, N, 50 Hz | 230 V, 1~, N, 50 Hz |
| Consumption of electric heating | 2 x 3500 W | 2 x 3500 W | 2 x 3500 W |
| Heating circuit pump consumption | 5 ... 87 W | 3 ... 140 W | 3 ... 140 W |
| Control power consumption in total | max 89 W | max 142 W | max 142 W |
| Regulation power consumption standby | 3 W | 3 W | 3 W |
| Type of protection | IP 40 | IP 40 | IP 40 |

⁽¹⁾ When using the second stage of the electric heating.

3 Product description

3.4.3 Installation location

Installation location | indoors

3.4.4 Ambient conditions

| | |
|--|------------------------|
| Temperature in operation | +3 ... +30 °C |
| Temperature during transport / storage | -10 ... +60 °C |
| relative humidity | max 80 %, no dew point |

3.4.5 Rating

| | | 8-B R-E HE | 10-B R-E HE | 13-B R-E HE | 10-B R HE | 13-B R HE | 16-B R HE |
|--|-----------------------|------------------------|------------------------|------------------------|------------------------|------------------------|------------------------|
| Evaporator air throughput | | 2700 m ³ /h | 4210 m ³ /h | 4210 m ³ /h | 3460 m ³ /h | 4210 m ³ /h | 4500 m ³ /h |
| Heating water flow rate con- denser | nominal ¹⁾ | 1.4 m ³ /h | 1.9 m ³ /h | 2.5 m ³ /h | 1.8 m ³ /h | 2.1 m ³ /h | 2.7 m ³ /h |
| | minimum | 0.8 m ³ /h | 1.0 m ³ /h | 1.2 m ³ /h | 1.0 m ³ /h | 1.2 m ³ /h | 1.3 m ³ /h |

¹⁾ Volumetric flow at standard nominal conditions A7 / W35 and temperature spread 5 K, to EN 14511-2.

3.4.5.1 Heating capacity (EN 14511)

| | 8-B R-E HE | 10-B R-E HE 13-B R-E HE | 10-B R HE 13-B R HE 16-B R HE |
|---|----------------|----------------------------|-------------------------------------|
| Heating water flow temperature | +20 ... +55 °C | +20 ... +55 °C | +20 ... +55 °C |
| Air temperature application limit outdoor unit | -20 ... +35 °C | -15 ... +35 °C | -20 ... +35 °C |

At nominal operating conditions A2 / W35

| | 8-B R-E HE | 10-B R-E HE | 13-B R-E HE | 10-B R HE | 13-B R HE | 16-B R HE |
|-------------------------------------|---------------|----------------|----------------|--------------|--------------|--------------|
| Heat capacity | 5.8 kW | 6.5 kW | 10.6 kW | 7.6 kW | 9.1 kW | 11.5 kW |
| Coefficient of performance (COP) | 3.62 | 3.73 | 3.26 | 3.79 | 3.72 | 3.72 |

At standard nominal conditions A7 / W35 and temperature spread 5 K

| | 8-B R-E HE | 10-B R-E HE | 13-B R-E HE | 10-B R HE | 13-B R HE | 16-B R HE |
|-------------------------------------|---------------|----------------|----------------|--------------|--------------|--------------|
| Heat capacity | 7.94 kW | 10.9 kW | 14.6 kW | 10.2 kW | 12.1 kW | 15.7 kW |
| Coefficient of performance (COP) | 4.7 | 4.62 | 4.29 | 5.08 | 4.69 | 4.17 |

3 Product description

Capacity graph heating 10-B R-E and 13-B R-E

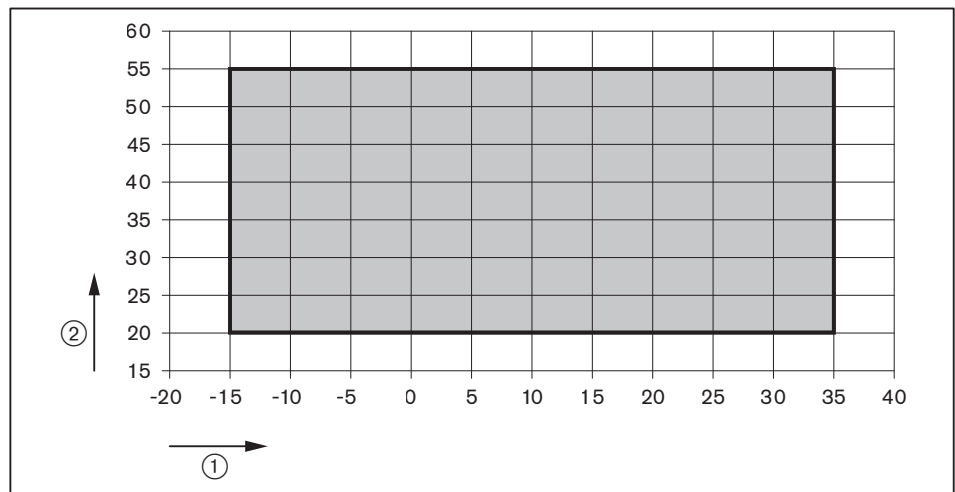

- ① Air intake temperature [°C]
- ② Flow temperature [°C]

Capacity graph heating 8-B R-E, 10-B R, 13-B R and 16-B R

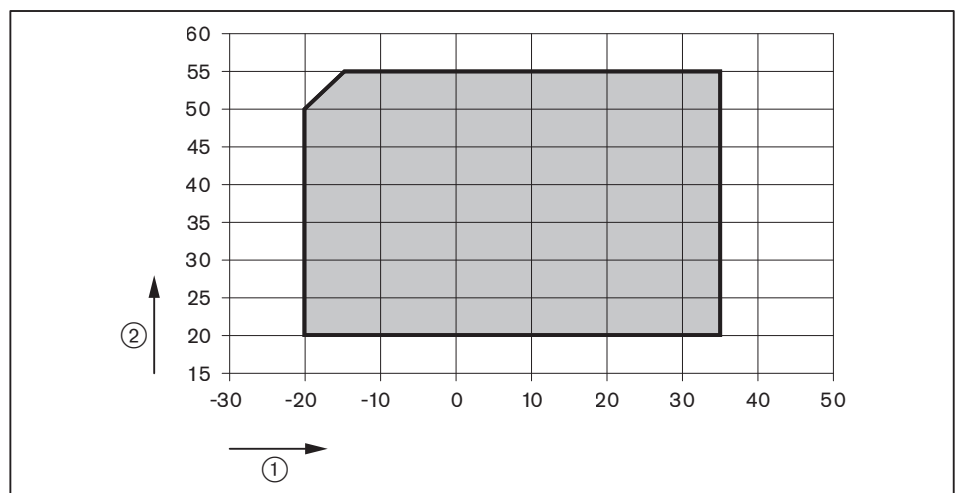

- ① Air intake temperature [°C]
- ② Flow temperature [°C]

3 Product description

3.4.5.2 Cooling capacity (EN 14511)

| | WWP LS 8-B R-E HE | WWP LS 10-B R-E HE WWP LS 13-B R-E HE | WWP LS 10-B R HE WWP LS 13-B R HE WWP LS 16-B R HE |
|--|-------------------|--|--|
| Cooling water flow temperature | +7 ... +20 °C | +7 ... +20 °C | +7 ... +20 °C |
| Air temperature application limit outdoor unit | +10 ... +45 °C | +10 ... +45 °C | +10 ... +45 °C |

At standard nominal conditions A35 / W7 and temperature spread 5 K

| | 8-B R-E HE | 10-B R-E HE | 13-B R-E HE | 10-B R HE | 13-B R HE | 16-B R HE |
|------------------------|------------|-------------|-------------|-----------|-----------|-----------|
| Cooling capacity | 6.6 kW | 7.4 kW | 9.1 kW | 9.1 kW | 10.8 kW | 11.8 kW |
| Efficiency ratio (EER) | 2.75 | 2.75 | 2.5 | 2.71 | 2.59 | 2.16 |

At standard nominal conditions A35 / W18 and temperature spread 5 K

| | 8-B R-E HE | 10-B R-E HE | 13-B R-E HE | 10-B R HE | 13-B R HE | 16-B R HE |
|------------------------|------------|-------------|-------------|-----------|-----------|-----------|
| Cooling capacity | 8.0 kW | 8.4 kW | 12.6 kW | 8.8 kW | 11.8 kW | 14.2 kW |
| Efficiency ratio (EER) | 3.5 | 3.8 | 3.0 | 4.46 | 3.8 | 3.37 |

Capacity graph cooling

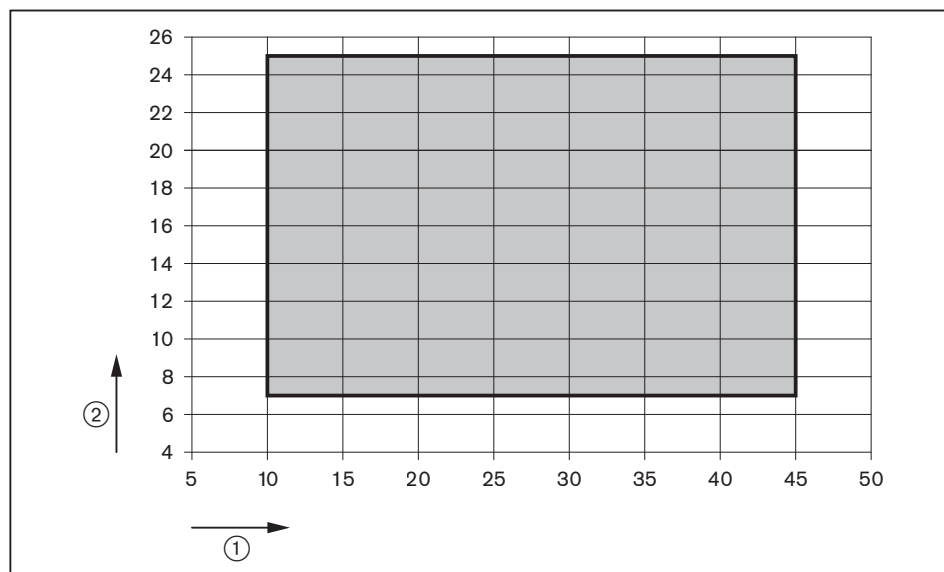

- ① Air intake temperature [°C]
- ② Flow temperature [°C]

3 Product description

3.4.5.3 Resulting supply pressure

WWP LS 8-B and WWP LS 10-B with pump UPM Geo 25-85

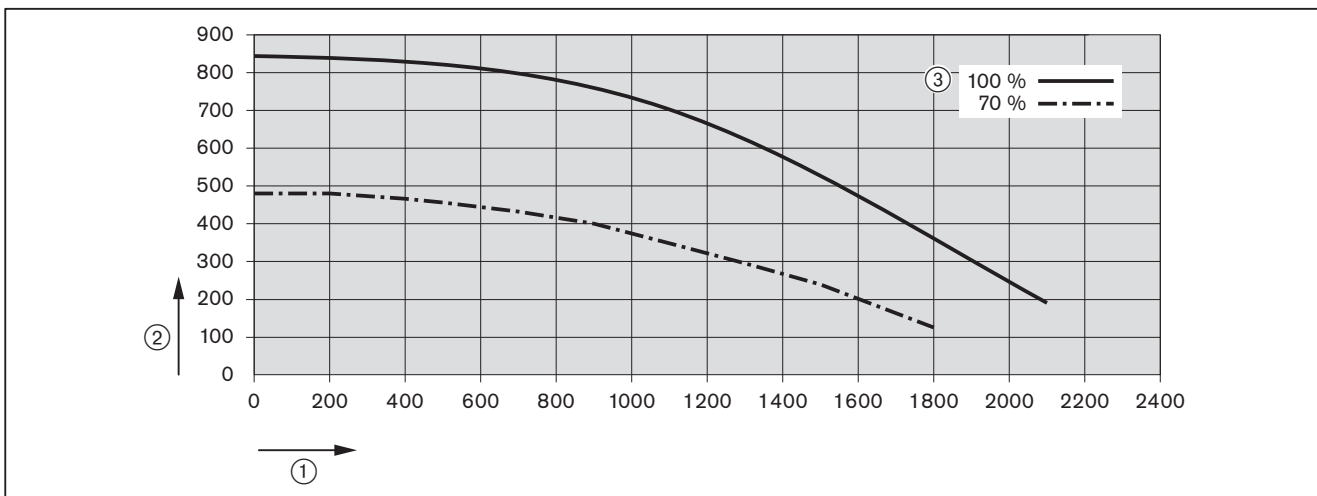

- ① Throughput [l/h]
- ② Resulting supply pressure [mbar]
- ③ Circulation pump capacity

WWP LS 13-B and WWP LS 16-B with pump UPML Geo 25-105

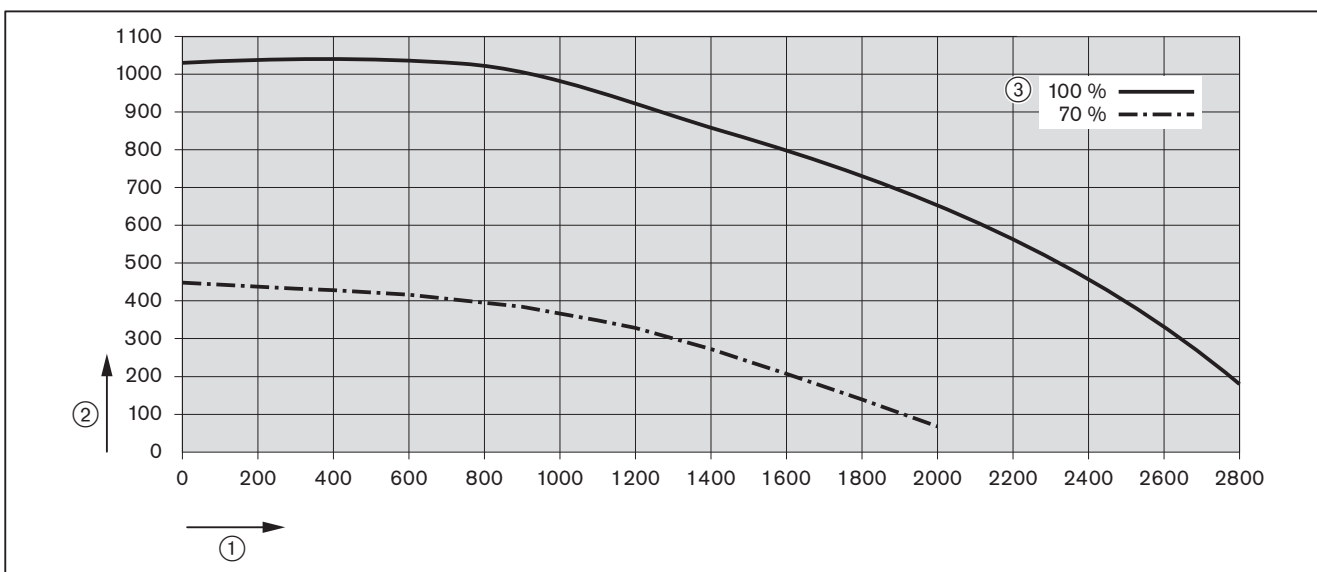

- ① Throughput [l/h]
- ② Resulting supply pressure [mbar]
- ③ Circulation pump capacity

3 Product description

3.4.6 Operating pressure

| | |
|---------------|------------|
| Refrigerant | max 42 bar |
| Heating water | max 3 bar |

3.4.7 Contents

Hydraulic unit and outdoor unit

| | 8-B R-E HE | 10-B R-E HE 13-B R-E HE 10-B R HE 13-B R HE | 16-B R HE |
|--------------------------------|------------------------|--|-----------------------|
| R410A refrigerant | 2.15 kg ⁽¹⁾ | 2.95 kg ⁽¹⁾ | 4.2 kg ⁽¹⁾ |
| Global Warming Potential (GWP) | 2088 | 2088 | 2088 |
| CO ₂ equivalent | 4.38 t | 6.16 t | 8.77 t |

⁽¹⁾ With more than 2.4 kg R410A refrigerant, an annual leakage test of the refrigerant circuit is mandatory.

3.4.8 Weight

| | 8-B R-E HE | 10-B R-E HE 10-B R HE | 13-B R-E HE 13-B R HE 16-B R HE |
|--------------|-------------------|----------------------------------|--|
| Empty weight | 54 kg | 56 kg | 60 kg |

3 Product description

3.4.9 Dimensions

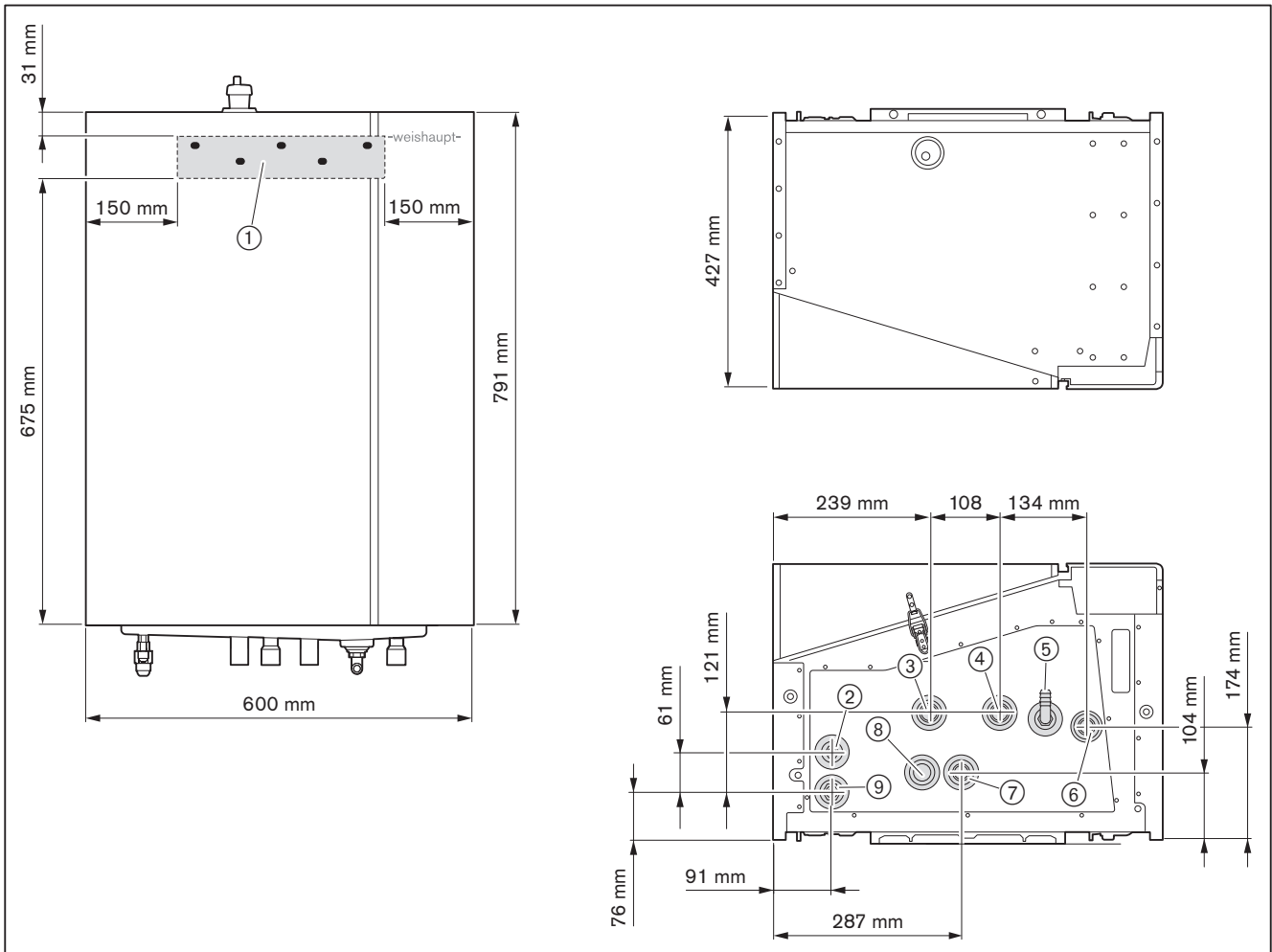

- ① Wall bracket (anchor bolt size \varnothing 10 mm)
- ② Refrigerant pipework $\frac{3}{8}$ " (liquid pipe)
- ③ Heating return \varnothing external 28 mm
- ④ DHW return \varnothing external 28 mm
- ⑤ Condensate connection
- ⑥ DHW flow \varnothing external 28 mm
- ⑦ Heating flow \varnothing external 28 mm
- ⑧ Safety valve outlet
- ⑨ Refrigerant pipework $\frac{5}{8}$ " (compressed gas line)

4 Installation

4 Installation

4.1 Installation conditions

Dimensions

Observe dimensions [ch. 3.4.9].

Installation location

- ▶ Prior to installation ensure that:
 - the installation location is frost free,
 - the bearing capacity of the wall is sufficient [ch. 3.4.8],
 - the space for the hydraulic unit is sufficient [ch. 3.4.9],
 - the space for the hydraulic connection is sufficient,
 - the installation location is of sufficient volume.

Minimum room volume

| | 8-B R-E HE | 10-B R-E HE 13-B R-E HE 10-B R HE 13-B R HE | 16-B R HE |
|----------------------------|---------------------------------|--|----------------------------------|
| Minimum room volume EN 378 | greater than 6.5 m ³ | greater than 8.0 m ³ | greater than 11.0 m ³ |

Minimum clearance

Maintain a side clearance of at least 20 cm to walls and/or objects during the installation or servicing work.

4.2 Remove front panel



The front panel is secured with a screw at the tension lock to prevent accidental opening.

- ▶ Refit screw when mounting front panel.

- ▶ Remove screw ① from tension lock at the underside of the unit.
- ▶ Open the tension lock and remove the front panel.

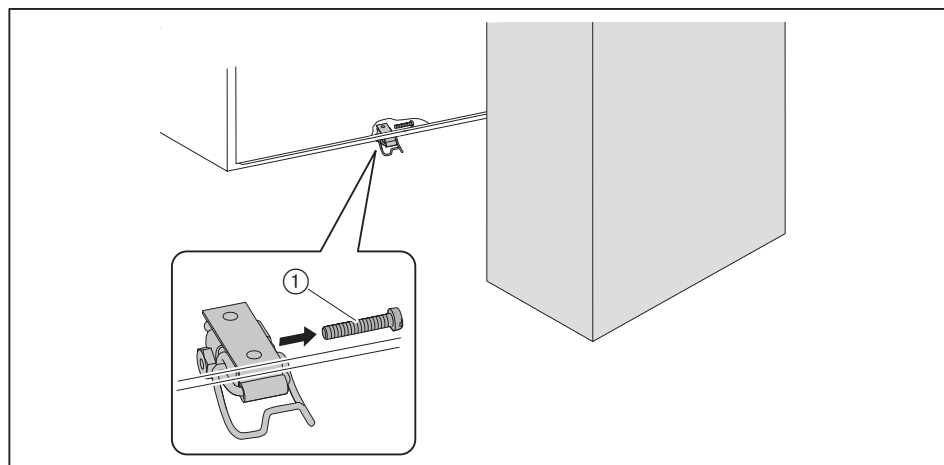

4 Installation

4.3 Mounting the wall bracket

Prior to installation the wall bracket supplied ensure that:

- sufficient space is available beneath the unit for the hydraulic connections,
 - the fixing material supplied is suitable for wall mounting [ch. 3.4.8].
- Position wall bracket, mark all fixing points and drill [ch. 3.4.9].
- Mount the wall bracket to the wall using all drilling positions.

4.4 Hanging and aligning the unit



Only when mounting a basic connection assembly (accessory)

- Assemble the basic connection assembly prior to mounting to the wall bracket.

- Hook the unit into the wall bracket ② and using the adjustment screws ① align horizontally.
- Adjust clearance to the wall using adjustment screws ③ and horizontally align the unit.

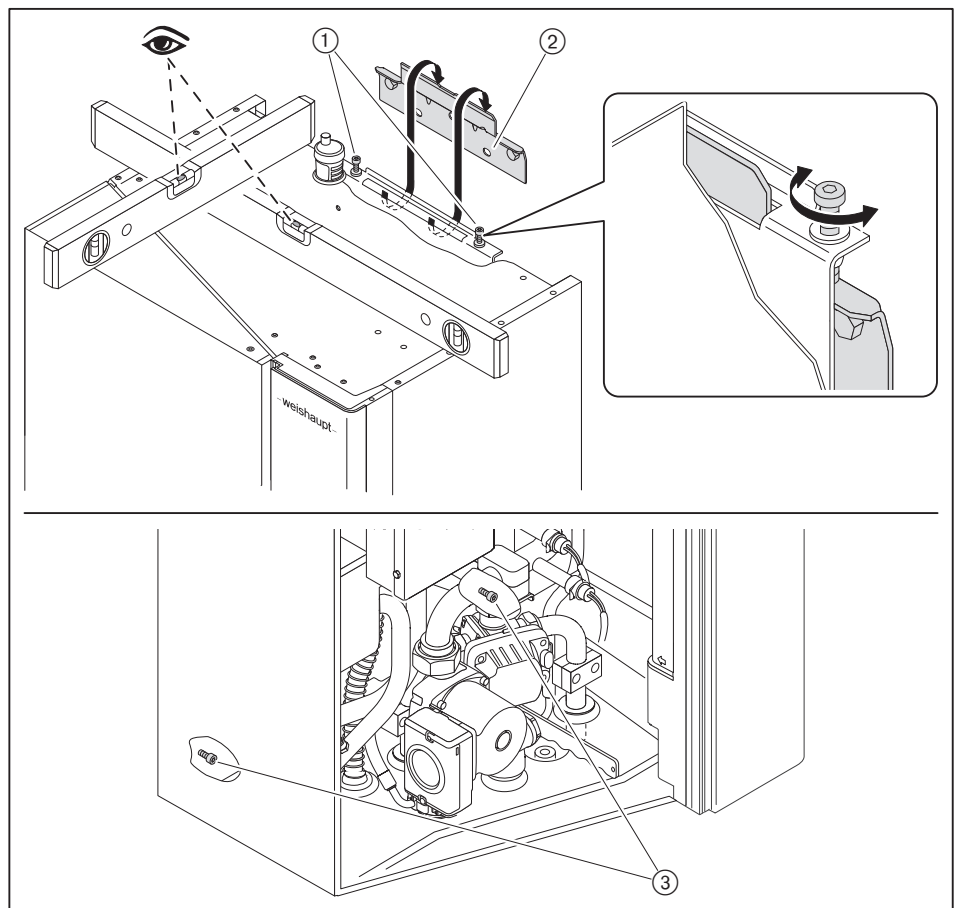

5 Installation

5 Installation

5.1 Requirements for the heating water



In support of VDI guideline 2035 the following requirements are applicable for heating water.

- Untreated fill and top-up water must be of domestic water quality (colourless, clear and without any sedimentation).
- The fill and top-up water must be pre-filtered (mesh max 5 µm).
- There must be no oxygen enrichment of the heating water (max 0.02 mg/l).
- With non-diffusion resistant system components, the unit must be de-coupled from the heating circuit by means of a separator.

With flow temperatures of 60 °C, calculus formation can not be completely avoided.

Guide values for the fill and top-up water:

| | |
|--------------------------|----------------------------|
| Total of alkaline earths | max 2.0 mol/m ³ |
| Total hardness | max 11.2 °dH |

5 Installation

5.2 Hydraulic connection



Observe the installation and operating manual of the outdoor unit when installing the refrigerant pipework.



DANGER

Risk of suffocation due to leaking refrigerant

Leaking refrigerant collects at the base of the unit. Inhalation may cause suffocation, and even death. Contact with the skin can cause frostbite.

- ▶ Do not damage refrigeration circuit.



WARNING

Environmental damage due to leaking refrigerant

Refrigerant contains fluorinated greenhouse gases in accordance with the Kyoto Protocol and must not be discharged into the atmosphere.

- ▶ Do not damage refrigeration circuit.

- ▶ Flush the heating system with at least twice the total system content.
- ✓ Contaminants are removed.
- ▶ Close flow and return (install shut off devices).

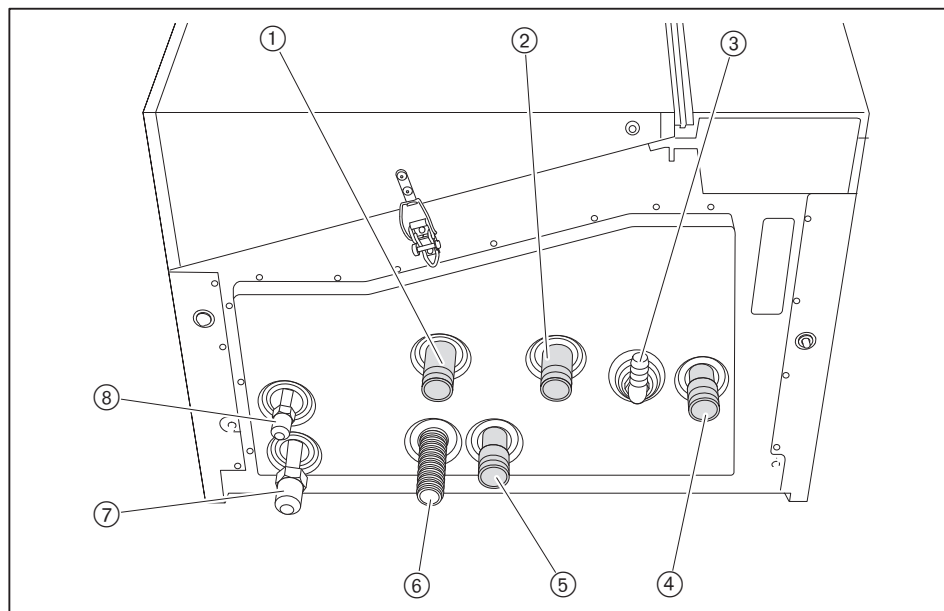

- ① Heating return Ø external 28 mm
- ② DHW return Ø external 28 mm
- ③ Condensate connection
- ④ DHW flow Ø external 28 mm
- ⑤ Heating flow Ø external 28 mm
- ⑥ Safety valve outlet
- ⑦ Refrigerant pipework 5/8" (compressed gas line)
- ⑧ Refrigerant pipework 3/8" (liquid pipe)

5 Installation

Filling with water



Damage to the unit due to unsuitable fill water

Corrosion and scale could damage the system.

- ▶ Adhere to the requirements for the heating water and the local directives [ch. 5.1].

-
- ▶ Check design and inlet pressure of the expansion vessel and adjust if necessary [ch. 12.1].

For defrosting, a water quantity of at least 60 litres must be present in the heating circuit.

System pressure = flow pressure + 0.5 bar.

- ▶ Open shut off devices.
- ▶ Undo cap on quick action vent valve.
- ▶ Gradually fill the heating system using the inlet tap whilst observing the system pressure.
- ▶ Vent the system.
- ▶ Check soundness and system pressure.

5.3 Refrigerant pipework

Connect refrigerant pipework, see installation and operating manual of outdoor unit.

5 Installation

5.4 Condensate connection



Place condensate hose in such a way that it is not possible for water bags to form (siphon effect) and the condensate can drain away unimpeded.

A condensate hose internal \varnothing 14 mm is supplied with the hydraulic unit.

- ▶ Connect condensate hose to the connection piece ① and drain into the sewage system.
- ▶ Outlet ② of the safety valve should drain into the sewage system.

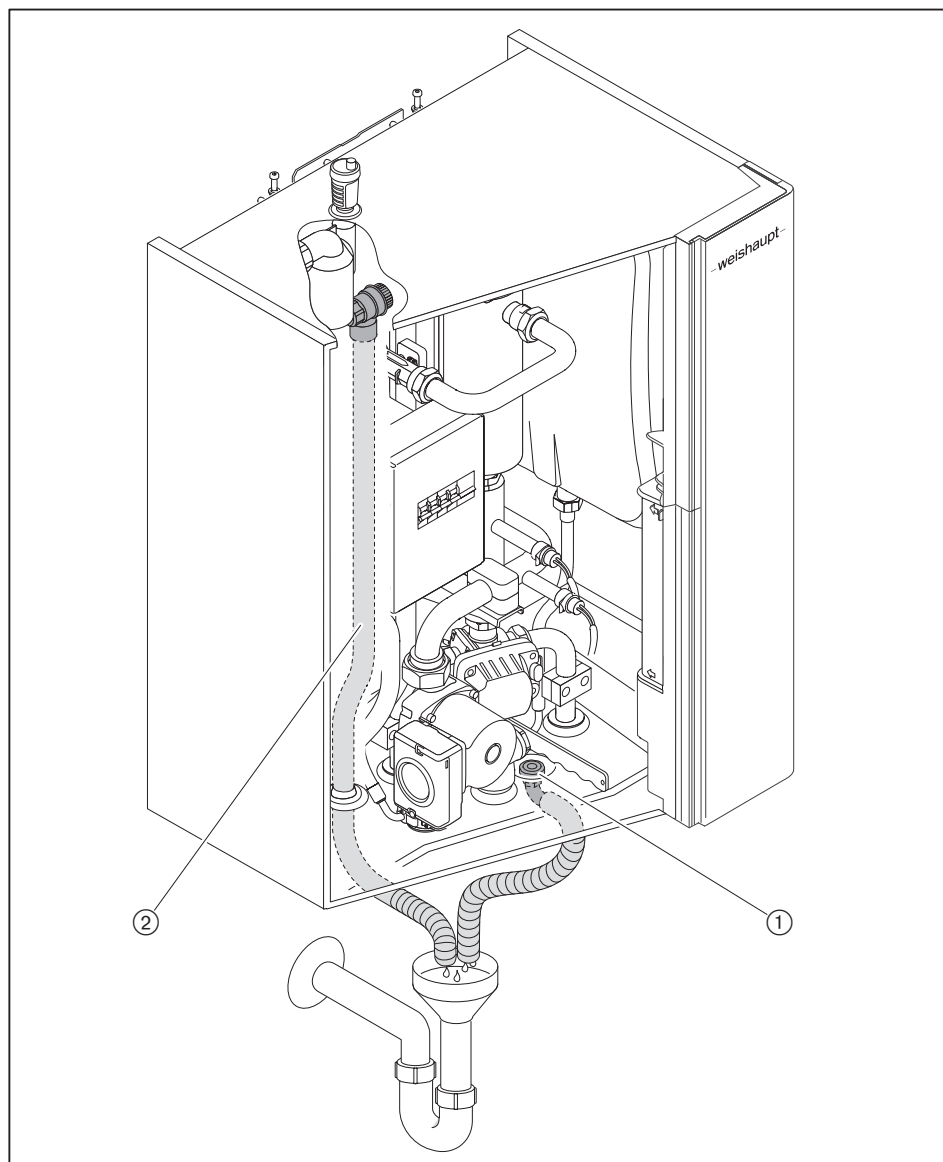

5 Installation

5.5 Electrical connection



Risk of electric shock

Working on the device when voltage is applied can lead to electric shock.

- ▶ Isolate hydraulic unit and outdoor unit from power supply prior to carrying out work.
- ▶ Safeguard against accidental restart.



Risk of electric shock

Working on the device when voltage is applied can lead to electric shock.

The electric heating in the hydraulic unit is equipped with a separate voltage supply.

- ▶ Isolate the electric heating from the power supply prior to starting any work.
- ▶ Safeguard against accidental restart.

The electrical connection must only be carried out by qualified electricians. Observe local regulations.



The preferred Bus line to be used is the 4 wire RJ11 shielded bus line (accessory).

- ▶ Run bus lines and external sensors separately and preferentially using shielded lines, placing the shield on to the existing shield plate.

Connect hydraulic unit

- ▶ Switch off switch S1 ①.
- ▶ Turn screw ② 90° anticlockwise.
- ▶ Remove cover from the electrical installation duct.

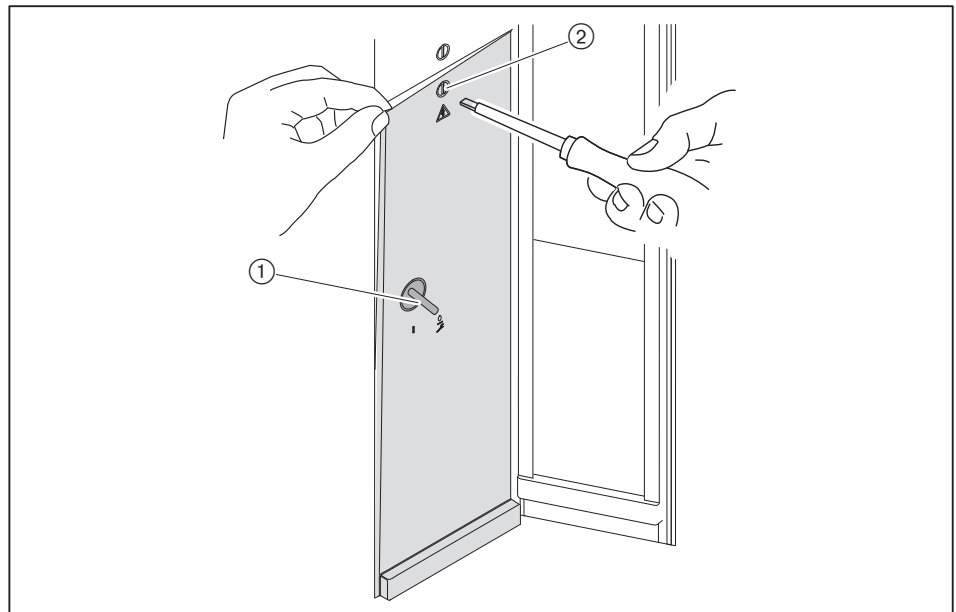

Risk of explosion due to excess pressure

When operating with closed service valves, a high pressure builds up. This can result in breakage of components.

- ▶ Only apply the voltage, if the service valves on the outdoor unit are open.

5 Installation

- ▶ Guide the lines from the rear or from the bottom of the unit through the recess to the wiring duct.
- ▶ Assign the inputs and outputs according to application.
- ▶ Connect the cables according to the wiring diagram, in the process pay particular attention to the correct phase location of the voltage supply.
- ▶ Secure the cables with the screw terminals for tension relief supplied.

Connect electric heating

- ▶ Undo screw ① and remove cover ② .
- ▶ Undo protective conductor connection ③ on the cover.
- ▶ Remove cover.

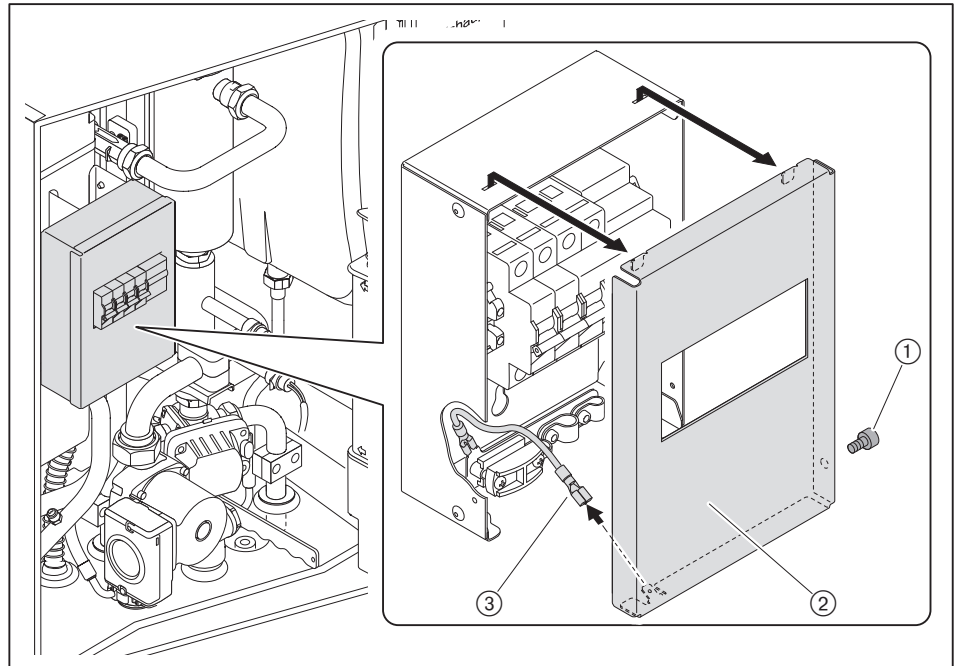

- ▶ Connect wiring as shown in the wiring diagram.
- ▶ Reconnect protective conductor connection to the cover.
- ▶ Fit cover.

5 Installation

5.5.1 Wiring diagram

Observe the instructions for the electrical installation [ch. 5.5].

WWP-CPU device electronic

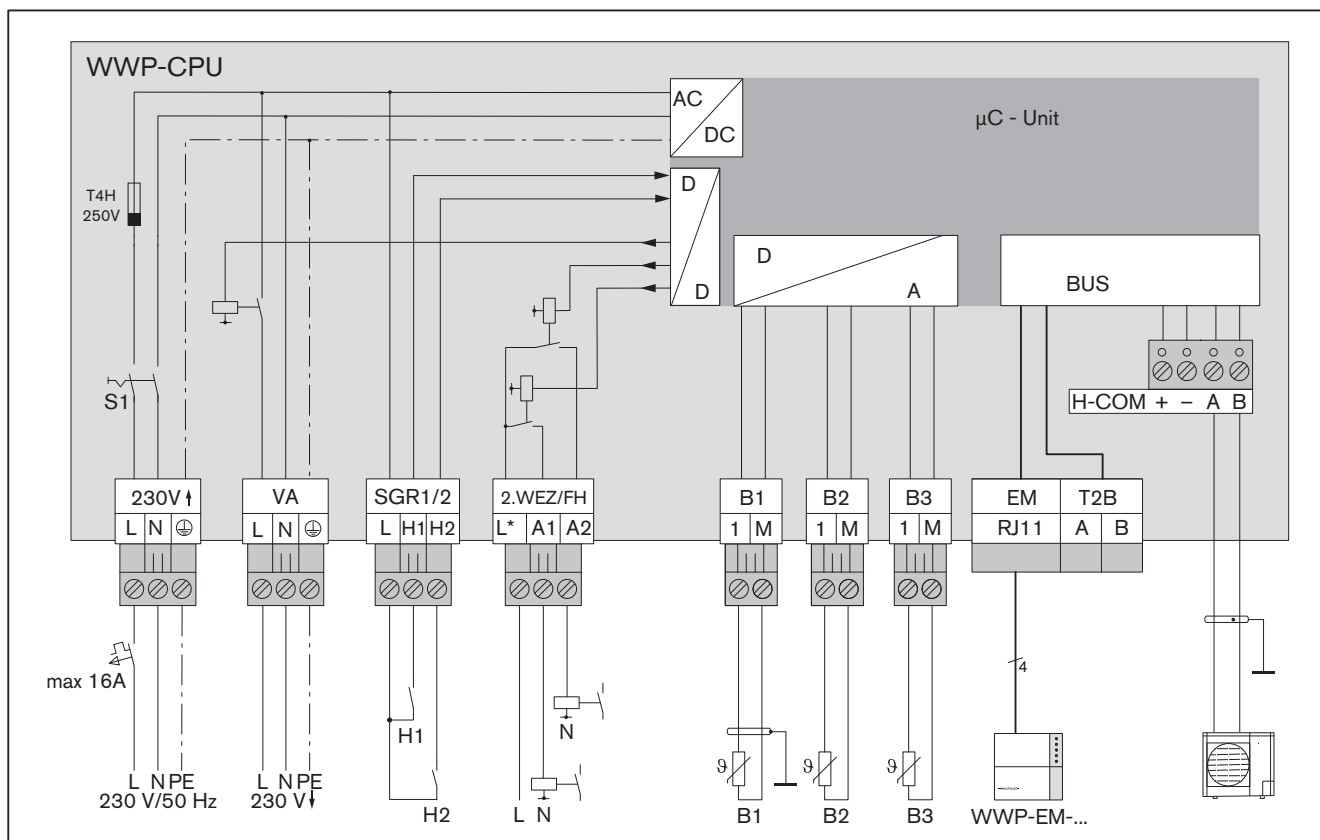

WWP-CPU device electronic

| Plug | Colour | Connection | Description |
|-------------|-----------|---|---|
| 230V ↑ | black | Voltage supply 230 V AC / 50 Hz | – |
| VA | grey | Variable output 230 V AC | max 2 A |
| SGR1/2 | turquoise | Input SG Ready H1 and H2 (EVU block) [ch. 11.2] | – |
| 2. WEZ / FH | purple | Potential free relay output 2nd heat exchanger (A1) / flange heating (A2) | – |
| B1 | green | External sensor (accessory) | NTC 2 kΩ |
| B2 | white | De-couple sensor | NTC 5 kΩ |
| B3 | yellow | DHW sensor | NTC 5 kΩ |
| EM RJ11 | – | WWP extension module | Bus line RJ11 4 wire, shielded (accessory) |
| T2B | dark grey | Reserve (not used) | – |
| H-COM | pink | Connection to outdoor unit (communication line) | 2 x 0.75 mm ² , shielded, twisted in pairs |

5 Installation

Electric heating

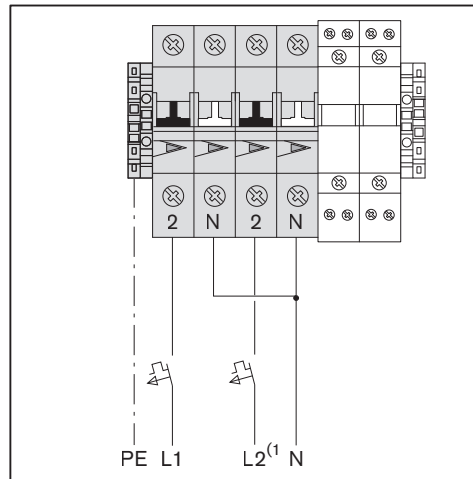

Electric heating

| Supply | Description |
|--|----------------------|
| Voltage supply 230 V, 1~, N, 50 Hz optional ⁽¹⁾ : 400 V, 3~, N, 50 Hz | External fuse B 20 A |

⁽¹⁾ When using the second stage of the electric heating.

6 Operation

6 Operation

6.1 Operational display

The light bar ① shows the operating status of the heat pump.

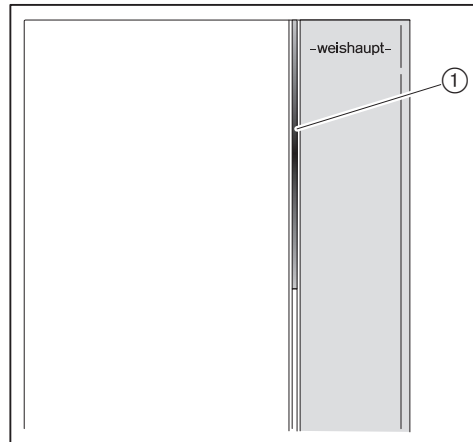

| Light bar | Description |
|-----------|--|
| OFF | No voltage supply or light bar deactivated [ch. 6.7.3.4] |
| Green | System is fault free |
| Yellow | Fault or Warning [ch. 10] |
| Red | Locked fault (system is in lockout) [ch. 10] |

6 Operation

6.2 Display and operating unit

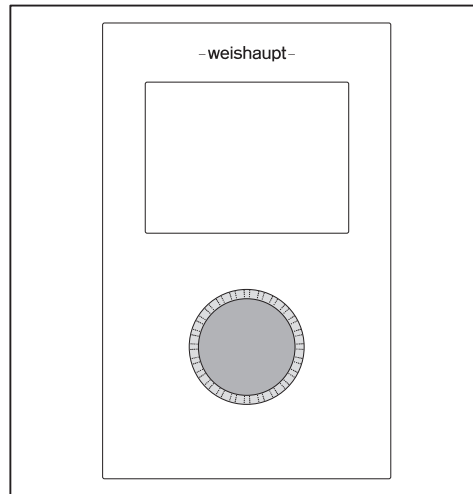

| | |
|-------|--|
| turn | navigation through parameter structure; changing values |
| press | confirm or save values |

6 Operation

6.3 Display

Start screen

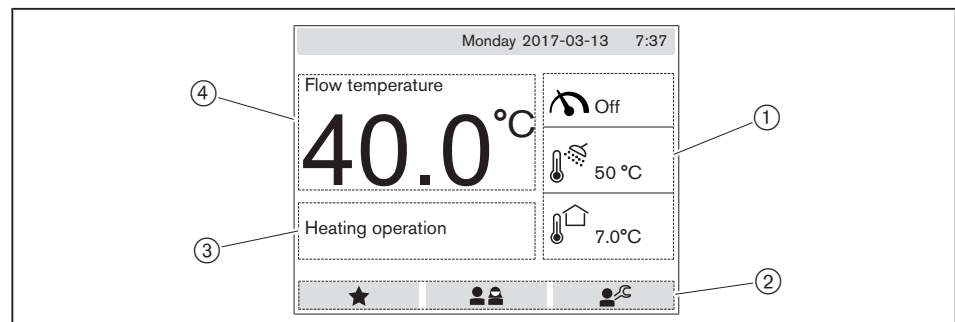

- | | |
|---|---|
| ① | <p>Information:</p> <ul style="list-style-type: none"> ▪ Current load demand on the outdoor unit ▪ DHW temperature ▪ External temperature |
| ② | <p>Level selection:</p> <ul style="list-style-type: none"> ▪ ★ Favourites level ▪ 👤 User level ▪ 👤🔧 Expert level <p>The dial knob is used to select the level.</p> |
| ③ | <p>Status display: Current status of the system.</p> <ul style="list-style-type: none"> ▪ Manual operation [ch. 6.7.5.1] ▪ Manual defrost [ch. 6.7.5.1] ▪ Diagnostic operation ▪ Automatic venting [ch. 6.7.5.1] ▪ Idle time (10 min block after controlled shutdown) ▪ Block external temperature <ul style="list-style-type: none"> - Summer block [ch. 6.7.5.2] - Limit temperature [ch. 6.7.1.3] ▪ Defrost (automatic defrost function of outdoor unit activated) ▪ Application limit ▪ EVU block [ch. 11.2] ▪ SG Ready HC (increased operation heating circuit) [ch. 11.2] ▪ SG Ready DHW (increased operation DHW) [ch. 11.2] ▪ Heating operation ▪ Cooling operation ▪ Legionella protection [ch. 6.7.4.4] ▪ DHW operation ▪ Summer <ul style="list-style-type: none"> - Summer operation set manually as system operating mode [ch. 6.7.2] - Summer operation activated automatically by external temperature [ch. 6.7.3.5] |
| ④ | <p>Temperature display: Current flow temperature of the system</p> |

6 Operation

6.4 Favourites level

For fast access, frequently required parameters are permanently stored in the Favourites level.



Depending on the hydraulics and control variations, certain information and parameters are hidden.

Display favourites

- ▶ Select Favourites level using dial knob and confirm.
- ✓ Display changes to Favourites level.

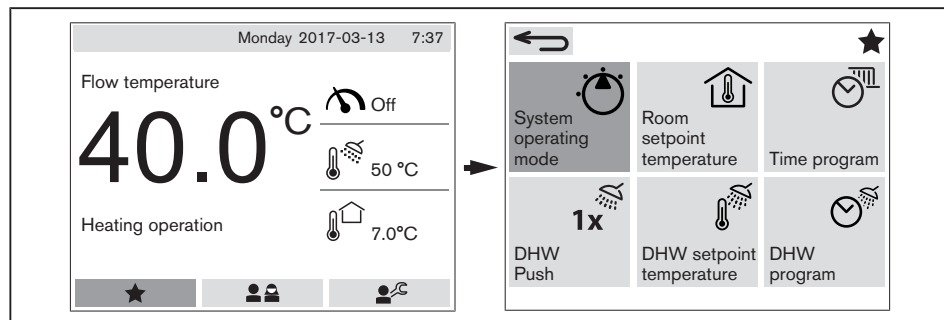

| Parameters | Description |
|--------------------------------|--|
| System operating mode | Determines the operating mode of the entire system. |
| Room setpoint temperature | Room setpoint temperature for the temperature level selected [ch. 6.4.1]. <ul style="list-style-type: none"> ▪ Comfort ▪ Normal ▪ Setback The levels can be assigned to specific times of the day using the heating program [ch. 6.4.3]. |
| Time program (heating program) | The heating program is used to stipulate the times of the day when comfort, normal or setback heating is used. The time program can be adapted individually [ch. 6.4.3]. The heating program is only activated in operating mode: <ul style="list-style-type: none"> ▪ Heating |
| 1x DHW Push | DHW Push can be used to cover hot water demand, which differs from the time program. The DHW tank is heated to and maintained at normal temperature for the duration set. |
| DHW setpoint temperature | DHW setpoint temperature for normal and setback operation [ch. 6.4.2]. <ul style="list-style-type: none"> ▪ Normal ▪ Setback Normal and setback operation can be assigned to specific times of the day using the DHW program [ch. 6.4.3]. |
| DHW program | The DHW program is used to stipulate the times of the day when the DHW tanks is heated to normal temperature or setback temperature. The time program can be adapted individually [ch. 6.4.3]. The DHW program is activated in operating mode: <ul style="list-style-type: none"> ▪ Heating ▪ Summer The DHW program is used to stipulate the times of the day when the DHW tanks is heated to normal temperature or setback temperature. |

6 Operation

6.4.1 Set room setpoint temperature

- ▶ Select temperature level using the dial knob and confirm.
- ✓ The display changes to the setting mode.
- ▶ Press the dial knob and set the desired temperature.
- ▶ Press dial knob and confirm entry.

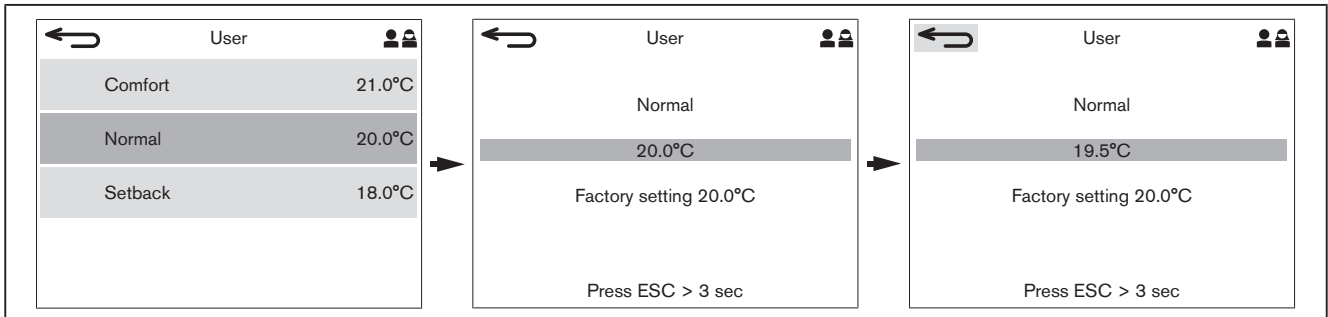

Temperature levels can be assigned to specific times of the day using menu *Time programs* , see [ch. 6.4.3].

6 Operation

6.4.2 Set DHW setpoint temperature

- ▶ Select temperature level using the dial knob and confirm.
- ✓ The display changes to the setting mode.
- ▶ Press the dial knob and set the desired temperature.
- ▶ Press dial knob and confirm entry.

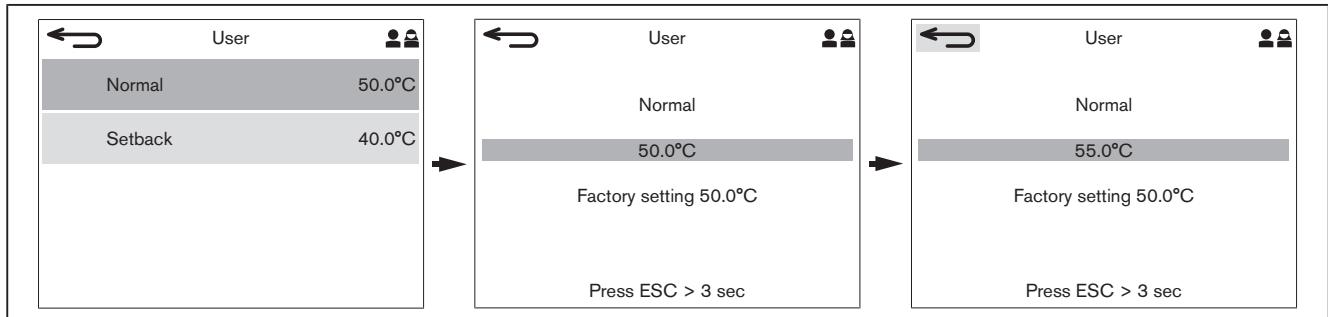

The DHW setpoint temperature should now be set as required.

The electric heating is switched on in addition for DHW setpoint temperatures with a flow setpoint above 55 °C. The flow setpoint results from the DHW setpoint temperature and the flow super-elevation [ch. 6.7.4.5].

6 Operation

6.4.3 Set time program

- ▶ Select time program.

| | |
|---|--------------|
|  | Heat program |
|  | DHW program |

Change / add time

- ▶ Select the time cycle of the relevant weekday using the dial knob.
- ✓ It is possible to program 3 cycles per weekday.
- ▶ Press the dial knob and set the start time.
- ▶ Press the dial knob and set the end time.
- ▶ Press the dial knob and set the temperature level (only possible in the heating program):
 - ☀: Comfort temperature (full sun),
 - ⚡: Normal temperature (half sun).
- ▶ Press dial knob.
- ✓ Weekday is highlighted, cycle is saved.

Edit next cycle or weekday:

- ▶ Turn dial knob clockwise and repeat procedure.

Exit time program:

- ▶ Turn dial knob anticlockwise until icon  is highlighted.
- ▶ Press dial knob.

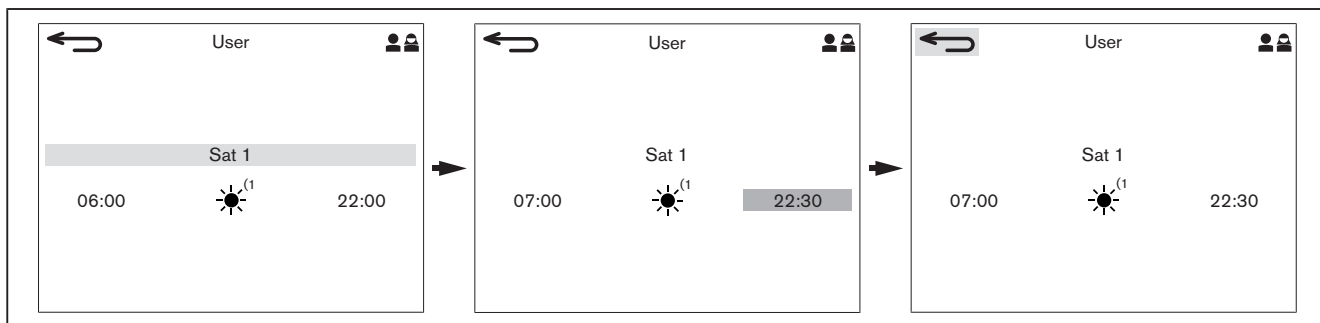

¹⁾ Symbol for temperature level only appears in heating program, it is not possible to make a selection in the DHW program.

6 Operation

Copy weekday

The settings for a weekday can be copied and applied to other days.

- ▶ Turn dial knob clockwise until `Copy` is displayed.
- ▶ Press dial knob and select the weekday to be copied.
- ▶ Press dial knob and select the weekday, which is to be overwritten.
 - `Off`: Copying is cancelled
 - `Mon ... Sun`: weekday selected is overwritten
 - `1-5`: Monday to Friday are overwritten
 - `6-7`: Saturday and Sunday are overwritten
 - `1-7`: Monday to Sunday are overwritten
- ▶ Press dial knob.
- ✓ Copying is carried out and saved.

Exit copying:

- ▶ Turn dial knob anticlockwise until `Off` is displayed.
- ▶ Press dial knob.
- ✓ Text line `Copying` is highlighted.
- ▶ Turn dial knob anticlockwise until icon  is highlighted.
- ▶ Press dial knob.

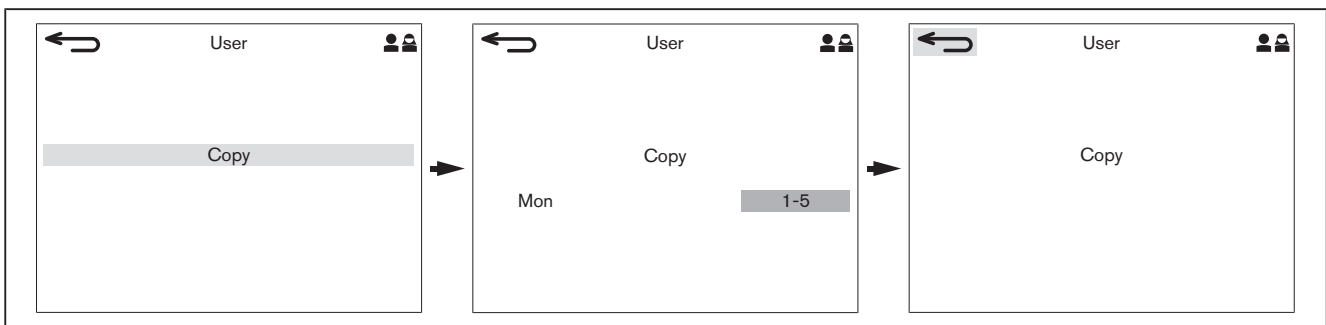

6 Operation

6.5 User level

Only menus and parameters required for the normal operation of the system are displayed in the user level.

- ▶ Select User level using dial knob and confirm.
- ✓ Display changes to the User level.

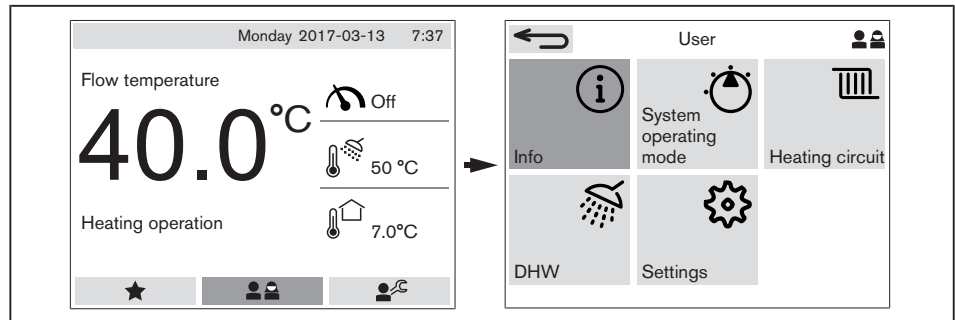

6 Operation

6.6 Expert level

All menus and parameters, which apply to the system are displayed in the expert level.

Access to the Expert level is only possible with a password.

Select password

Password: 11

- ▶ Select Expert level using dial knob and confirm.
- ✓ Display changes to Password window.
- ▶ Select Password 11 and confirm.
- ▶ Select icon ▶▶ and confirm.
- ✓ Display changes to Expert level.

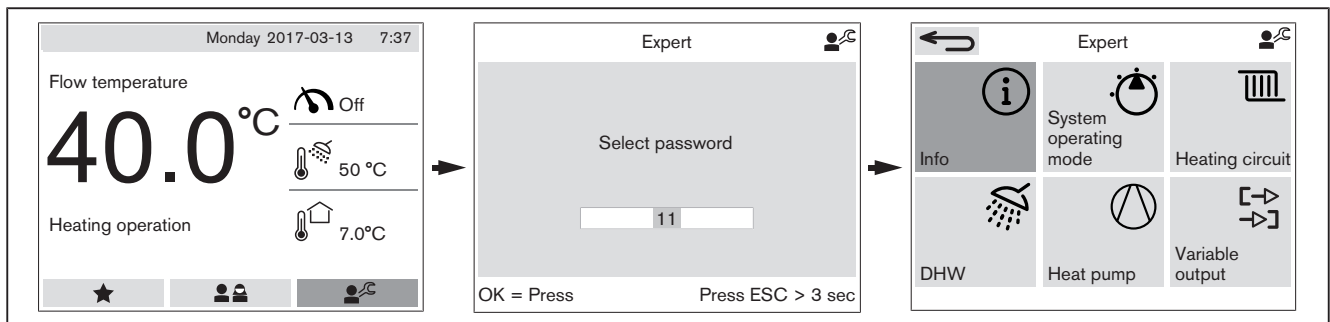

Deactivating password

If the dial knob is not operated for 3 minutes or you exit the expert level the password is deactivated.

6 Operation

6.7 Menu structure

In the user level, access to the menu structure is limited [ch. 6.5].
All information and parameters can be accessed via the expert level [ch. 6.6].



Depending on the hydraulics and control variations, certain information and parameters are hidden.

6.7.1 Info

In menu Info, the information is read only.

6.7.1.1 Heating circuit

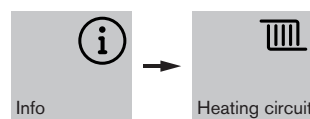

| Information | Description |
|---|--|
| External temperature | Current temperature at the external sensor (B1). |
| DHW temperature | Current temperature at the DHW sensor (B3). |
| Load demand | Current load demand to external unit. |
| Flow setpoint temperature ⁽¹⁾ | Flow setpoint temperature required by the heating circuit. |
| Flow temperature | Current flow temperature of heating circuit, measured at the flow sensor downstream of electric heating (B7). |
| Dynamic switch differential ⁽¹⁾ | Switch-on criteria for the heat pump. If the current flow temperature drops below the flow setpoint temperature by the value displayed, the heat pump starts. Only activated if Dynamic switch differential is set to On, see [ch. 6.7.5.2]. |
| Return temperature | Current return temperature of heating circuit, measured at return sensor (B9). |
| De-couple temperature | Current temperature at de-couple sensor (B2). |
| Speed pump ⁽¹⁾ | Current speed of pump in heating mode. |
| Volumetric flow ⁽¹⁾ | Current volumetric flow at flow sensor (B10) of the hydraulic unit. |
| Setting of change-over valve ⁽¹⁾ | Current setting of three way valve of hydraulic unit. |
| Version WWP-SG ⁽¹⁾ | Current software version of system device. |
| Version WWP-CPU ⁽¹⁾ | Current software version of device circuit board. |

⁽¹⁾ Only appears in Expert level.

6 Operation

6.7.1.2 Heat pump

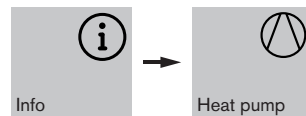

| Information | Description |
|--|--|
| Status outdoor unit | Current operating phase of outdoor unit. |
| Setpoint compressor frequency ⁽¹⁾ | Compressor frequency required by controller. |
| Actual compressor frequency ⁽¹⁾ | Current compressor frequency on outdoor unit. |
| Air intake temperature ⁽¹⁾ | Current air intake temperature at heat exchanger of outdoor unit. <ul style="list-style-type: none"> ▪ Air intake sensor (OAT) |
| Heat exchanger OU inlet ⁽¹⁾ | Current refrigerant temperature, measured at inlet of heat exchanger in outdoor unit (vaporiser). <ul style="list-style-type: none"> ▪ Heat exchanger sensor OU inlet (OCT) |
| Heat exchanger OU centre ⁽¹⁾ | Current temperature in heat exchanger of outdoor unit (vaporiser). <ul style="list-style-type: none"> ▪ Heat exchanger sensor OU centre (OMT) |
| Compressed gas ⁽¹⁾ | Current refrigerant temperature, measured at outlet of vaporiser in the outdoor unit. <ul style="list-style-type: none"> ▪ Compressed gas temperature sensor (CTT) |
| Heat exchanger internal ⁽¹⁾ | Current refrigerant temperature, measured at inlet of heat exchanger of hydraulic unit (compressed gas). <ul style="list-style-type: none"> ▪ Internal heat exchanger pressure sensor (B12) |
| Refrigerant internal ⁽¹⁾ | Current refrigerant temperature, measured at outlet of heat exchanger in indoor unit (condenser). <ul style="list-style-type: none"> ▪ Internal refrigerant sensor (B8) |
| Vaporiser operating hours ⁽¹⁾ | Operating hours of vaporiser since commissioning. |
| Operating cycles vaporiser ⁽¹⁾ | Number of vaporiser starts since commissioning. |
| Operating cycles defrost ⁽¹⁾ | Number of defrosts at outdoor unit since commissioning. |
| Outdoor unit variation | Type and version of outdoor unit. |

⁽¹⁾ Only appears in Expert level.

6 Operation

6.7.1.3 Second heat exchanger



| Information | Description |
|--|--|
| Status E-heating 1 | Current status of electric heating in the hydraulic unit, stage 1. |
| Status E-heating 2 | Current status of electric heating in the hydraulic unit, stage 2. |
| Status 2. WEZ | Current status of second heat exchanger (e. g. condensing unit). |
| Operating hours E1 | Operating hours of electric heating stage 1 since commissioning. |
| Operating hours E2 | Operating hours of electric heating stage 2 since commissioning. |
| Operating hours second WEZ | Operating hours of second heat exchanger since commissioning. |
| Operating cycles E1 ⁽¹⁾ | Number of switch-on cycles of electric heating stage 1. |
| Operating cycles E2 ⁽¹⁾ | Number of switch-on cycles of electric heating stage 2. |
| Operating cycles second WEZ ⁽¹⁾ | Number of starts of second heat exchanger (e. g. condensing unit). |







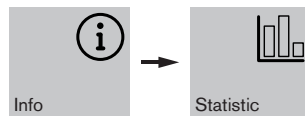







⁽¹⁾ Only appears in Expert level.

6 Operation

6.7.1.4 Statistic



In the `Statistic` menu, daily, monthly and annual values relating to the energy generated can be displayed.

| Information | Description |
|---|--|
|  Total energy days | Total energy generation during the current day. |
|  Total energy months | Total energy generation during the current month. |
|  Total energy years | Total energy generation during the current calendar year. |
|  Heating energy days | Energy required in heating mode during the current day. |
|  Heating energy months | Energy required in heating mode during the current month. |
|  Heating energy years | Energy required in heating mode during the current calendar year. |
|  DHW energy day | Energy required for DHW during the current day. |
|  DHW energy month | Energy required for DHW during the current month. |
|  DHW energy year | Energy required for DHW during the current calendar year. |
|  Cooling energy days | Energy required in cooling mode during the current day. |
|  Cooling energy months | Energy required in cooling mode during the current month. |
|  Cooling energy years | Energy required in cooling mode during the current calendar year. |
|  Defrost energy day | Energy required for defrost function during the current day. |
|  Defrost energy month | Energy required for defrost function during the current month. |
|  Defrost energy year | Energy required for defrost function during the current calendar year. |

6 Operation

6.7.2 System operating mode

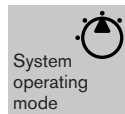

Menu System operating mode determines the operating mode of the entire system.

| Setting | Description |
|---------|---|
| Heating | Heating mode: <ul style="list-style-type: none">▪ Heating on▪ DHW on▪ Frost protection on |
| Summer | Summer operation: <ul style="list-style-type: none">▪ Heating off▪ DHW on▪ Frost protection on |
| Standby | Frost protection activated: <ul style="list-style-type: none">▪ Heating off▪ DHW off▪ Frost protection on |

6 Operation

6.7.3 Heating circuit

6.7.3.1 Party/Pause

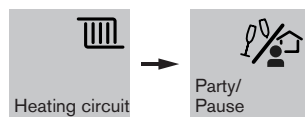

The temperature level of the heating program can be temporarily changed (maximum 12 hours). After this time the current heating program will be reactivated.

If the parameter is set to *Automatic*, the heating program is activated.

| Setting | Description |
|---------|--|
| Party | The heat pumps heats to normal temperature for the duration of the time set [ch. 6.4]. |
| Pause | The system operates on setback temperature for the duration of the time set [ch. 6.4]. |

Set duration of Party/Pause

- ▶ Select menu *Party/Pause* .
- ✓ The display shows the current operating mode.
- ▶ Press dial knob and set required function (*Party* or *Pause*).
- ▶ Set duration required using dial knob.
- ▶ Press dial knob and confirm entry.

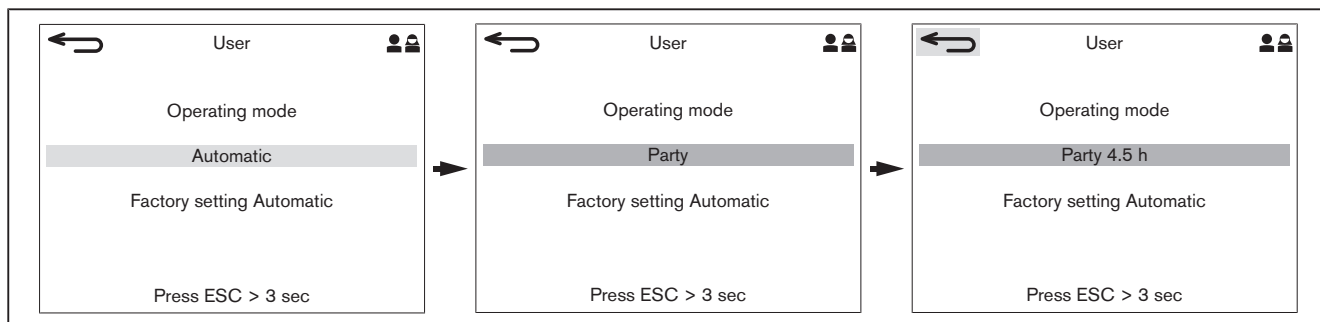

Reset Party/Pause

- ▶ Select menu *Party/Pause* .
- ▶ Select *Factory setting Automatic* and confirm.
- ✓ Operating mode changes to *Automatic*, *Party/Pause* function is reset.

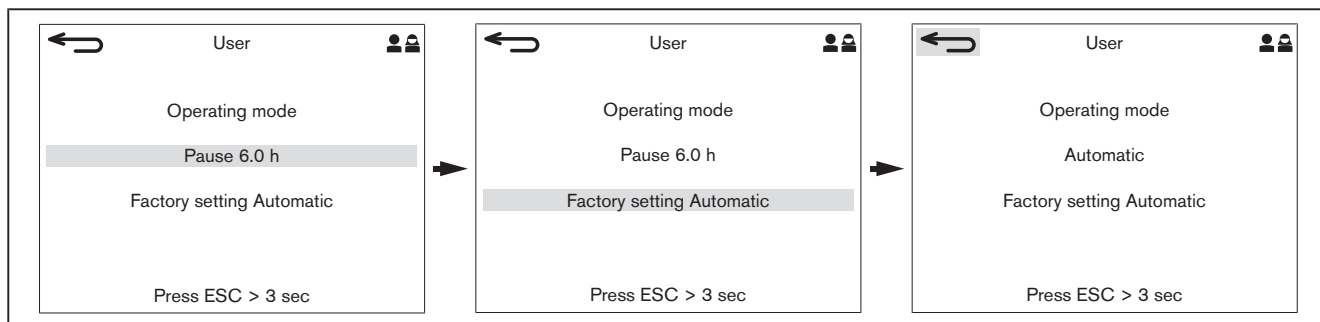

6 Operation

6.7.3.2 Room setpoint temperature

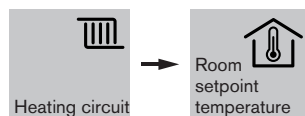

Stipulates the room setpoint temperature for the temperature level selected.

- Comfort
- Normal
- Setback
- Frost (Expert level only)

Temperature levels can be assigned to specific times of the day using menu `Time programs`, see [ch. 6.4.3].

6.7.3.3 Heating characteristic curve

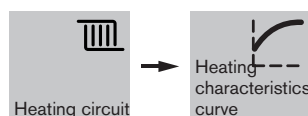

A higher flow temperature is required to achieve the desired room temperature, when external temperatures are lower.
The heating characteristics curve determines how much a change in external temperature affects the flow setpoint temperature.
If the `Room setpoint temperature` is changed, the heating characteristics curve is automatically adapted.

| | Room temperature too cold | Room temperature too warm |
|----------------------------------|---|---|
| Cold external temperature | ▶ Increase gradient. | ▶ Decrease gradient. |
| Mild external temperature | ▶ Increase comfort, normal and setback room setpoint temperature. | ▶ Decrease comfort, normal and setback room setpoint temperature. |

- ▶ Press dial knob.
- ✓ The display changes to the setting mode.
- ▶ Use dial knob to change heating characteristics curve (gradient).
- ▶ Press dial knob and confirm entry.
- ✓ The value is accepted and the setting range is highlighted in dark grey.

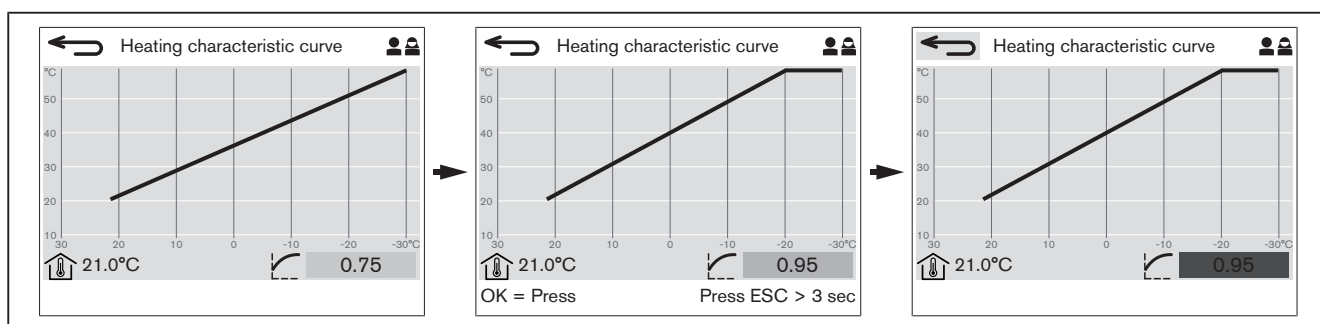

Factory setting: 0.75

In menu `Heating`, a lower and upper limit value can be set for the flow setpoint temperature [ch. 6.7.5.6].

6 Operation

6.7.3.4 Settings

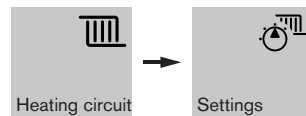

The menu is only displayed in the Expert level.

| Parameters | Setting |
|----------------------------|---|
| Function | <p>Off: No heating operation, only DHW loading possible. Menus and parameters relating to the heating circuit are hidden.</p> <p>On: Heating operation possible. Menus and parameters relating to the heating circuit are displayed.</p> |
| Demand | <p>Weather compensated: With weather compensated control, the flow temperature is regulated depending on the external temperature.</p> <p>The current flow temperature is calculated from the:</p> <ul style="list-style-type: none"> ▪ external temperature, ▪ heating characteristics curve [ch. 6.7.3.3], ▪ room setpoint temperature. <p>Fixed value: The flow temperature is regulated to the value set under <code>Constant temperature</code>, see [ch. 6.7.5.1].</p> |
| Screed | <p>Off: Screed program deactivated.</p> <p>Function specific heating: Function specific heating curve activated. First phase of drying. The function specific heating is used to ensure defect-free preparation for underfloor heating.</p> <p>Screed drying: Screed drying curve activated. Second phase of drying. Screed drying is used to continue drying ready for floor covering work.</p> <p>Function specific heating and screed drying: Function specific heating and screed drying activated one after the other.</p> |
| External sensor allocation | <p>Defines the relevant external sensor for the control.</p> <p>External temperature: External sensor B1 (accessory) [ch. 5.5.1].</p> <p>Air intake temperature: Air intake sensor (OAT) in outdoor unit.</p> |
| Frost protection | <p>Off: Frost protection deactivated.</p> <p>-20°C ... +29°C: If the current external temperature drops below the value set, system frost protection is activated.</p> |
| SG Ready increase | <p>Increase of flow setpoint temperature in heating operation with Smart-Grid function in operating mode 3 [ch. 11.2].</p> |
| Constant temperature | <p>Fixed flow temperature for heating operation. This parameter only appears, if the option <code>Fixed value</code> has been set under <code>Demand</code>.</p> |
| Setback mode | <p>Temperature level for the setback phases in the heating program [ch. 6.7.3.2].</p> <ul style="list-style-type: none"> ▪ Frost ▪ Setback |

6 Operation

| Parameters | Setting |
|---------------------|--|
| Building | With weather compensated control the mixed external temperature influences the flow setpoint temperature. The influence depends on the building construction. The better (heavier) the building construction, the slower the influence. ▪ Off, light, medium, heavy |
| Minimum temperature | Lower limit for the minimum flow temperature. Lower heat demands are limited to the value set. |
| Maximum temperature | Upper limit for the maximum flow temperature. Higher heat demands are limited to the value set. |
| Demand increase | The flow setpoint temperature of the heating circuit is increased by the value set, e. g. to compensate for load losses. |

Screed program

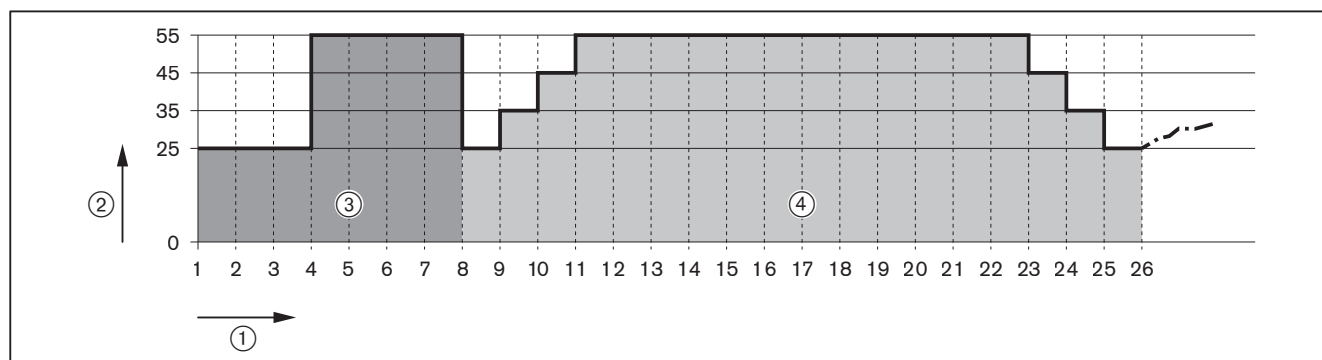

- ① Days
- ② Flow setpoint temperature [°C]
- ③ Function specific heating
- ④ Screed drying

6.7.3.5 Summer/Winter change-over

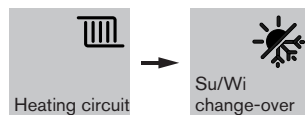

| Setting | Description |
|-----------------|--|
| 3.0 ... 30.0 °C | If the average external temperature exceeds the value set, the operating mode changes to <i>Summer</i> . |
| OFF | The operating mode set remains activated, independent of the external temperature. |

6.7.3.6 Time programs

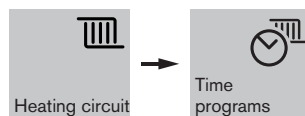

The heating program is used to stipulate the times of the day when comfort, normal or setback heating is used.
The time program can be adapted individually [ch. 6.4.3].
The heating program is only activated in operating mode *Heating*.

6 Operation

6.7.3.7 Cooling

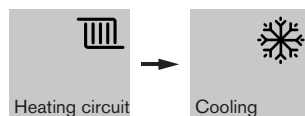

The menu is only displayed in the Expert level.

| Parameters | Setting |
|--------------------------|--|
| Release of cooling mode | Releases the cooling mode for the heating circuit. Additional parameters appear in menu <code>Cooling</code> . Cooling mode is only possible within the switch times for comfort and normal temperature. Cooling is not possible in the switch times for setback operation [ch. 6.7.3.6]. |
| Reference line ET min | Minimum external temperature for cooling function. If the average external temperature exceeds the value set, the operating mode changes to cooling. The minimum external temperature is the reference point for <code>Reference field flow min.</code> |
| Reference line ET max | Maximum external temperature for cooling reference line. The minimum temperature is the reference point for <code>Reference field flow MAX.</code> |
| Reference field flow MIN | Flow setpoint temperature, if the external temperature reaches the <code>Reference line ET min set.</code> Lower point of cooling reference line. |
| Reference field flow MAX | Flow setpoint temperature, if the external temperature reaches the <code>Reference line ET max set.</code> Upper point of cooling reference line. |
| Minimum temperature | Minimum flow temperature in heating circuit during active cooling. Lower limit value for the flow setpoint temperature of the cooling reference line. |
| Maximum temperature | Maximum flow temperature in heating circuit during active cooling. Upper limit value for the flow setpoint temperature of the cooling reference line. |
| Demand increase | The value set is added to the flow setpoint temperature, positive and negative. The demand increase has the function of a parallel displacement of the cooling reference line. |

Cooling reference line

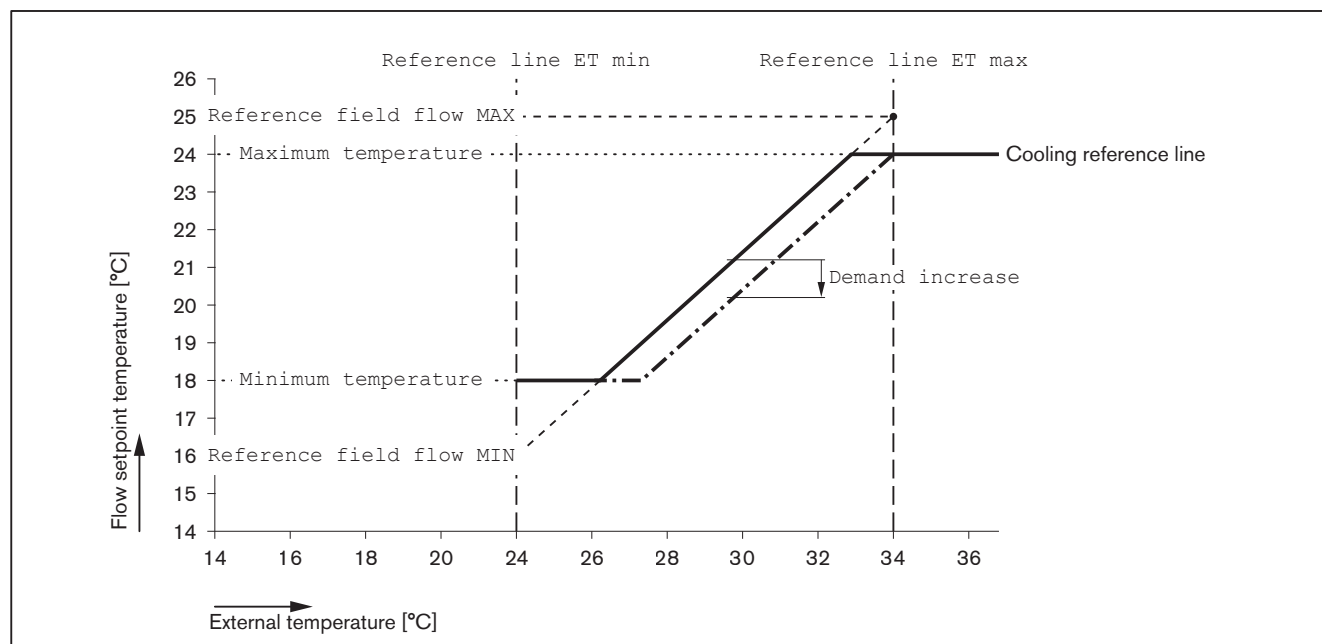

6 Operation

6.7.3.8 Reset

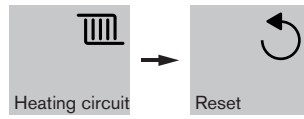

The menu is only displayed in the Expert level.

Reset all changes made in the heating circuit menu to factory settings.

6 Operation

6.7.4 Domestic hot water

6.7.4.1 Time programs

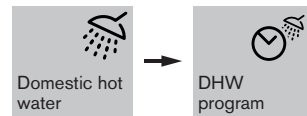

The DHW program is used to stipulate the times of the day when the DHW tanks is heated to normal temperature or setback temperature.

The time program can be adapted individually [ch. 6.4.3].

The DHW program is activated in operating mode:

- Heating
- Summer

6.7.4.2 DHW Push

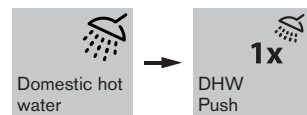

DHW Push can be used to cover hot water demand, which differs from the time program.

The DHW tank is heated to and maintained at normal temperature for the duration set.

6.7.4.3 DHW setpoint temperature

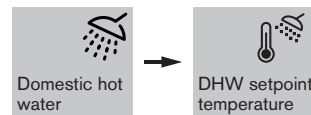

DHW setpoint temperature for normal and setbackoperation [ch. 6.4.2].

- Normal
- Setback

Normal and setback operation can be assigned to specific times of the day using the DHW program [ch. 6.4.3].

6 Operation

6.7.4.4 Legionella protection

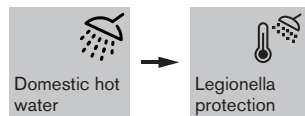

The menu is only displayed in the Expert level.

| Parameters | Setting |
|--------------|--|
| Day | Off: Legionella protection deactivated. Mon-Sun, all: Weekday on which Legionella protection is carried out. |
| Time | Time for the start of Legionella protection. |
| Temperature | DHW setpoint temperature for Legionella protection. |
| Loading time | Maximum duration for Legionella protection. Off: Legionella protection is not cancelled. 5 ... 240min: If the DHW setpoint temperature for Legionella protection is not reached in the time set, Legionella protection is cancelled. |

6.7.4.5 Settings



| Parameters | Setting |
|---------------------|---|
| SG Ready increase | Increase of the DHW setpoint temperature with Smart-Grid function in operating mode 3 [ch. 11.2]. |
| Maximum temperature | Upper limit value of DHW setpoint temperature with Smart-Grid function in operating mode 4 [ch. 11.2]. |
| Flow increase | Temperature increase of DHW setpoint for DHW loading. Flow setpoint temperature = DHW setpoint temperature + flow increase |

6 Operation

6.7.4.6 Flange heating



The menu is only displayed in the Expert level.

| Parameters | Setting |
|-------------------------|--|
| Change-over temperature | <p>Release temperature for flange heating in the domestic water storage tank.</p> <p>If the temperature in the storage tank exceeds <code>change-over temperature</code> set and if the DHW setpoint temperature has not been reached, the flange heating takes over the entire DHW loading. The heat pump switches off or changes over to heating mode.</p> |
| Switch differential | <p>Switch-off hysteresis for flange heating.</p> <p>If the DHW temperature drops below the <code>change-over temperature</code> by the <code>switch differential</code> set, the flange heating switches off and the heat pump takes over DHW loading.</p> |

6.7.4.7 Reset



The menu is only displayed in the Expert level.

Reset all changes made in the DHW menu to factory settings.

6 Operation

6.7.5 Heat pump

6.7.5.1 Service

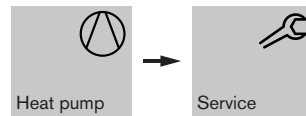

The menu is only displayed in the Expert level.

| Parameters | Setting |
|-------------------|--|
| Automatic venting | Program for filling and venting the heating side. During the automatic venting, the three way valve switches back and forth between heating mode and DHW loading. The pump changes the load several times in each setting. Automatic venting takes approx. 1 hour, but can be cancelled manually using the setting <code>Off</code> . |
| ManualOperation | <code>Off</code> : Manual operation deactivated. <code>20 ... 45°C</code> : Fixed value for flow setpoint temperature. |
| Manual defrost | <code>Off</code> : Manual defrost deactivated. <code>Execute</code> : Starts the defrost function, the heat exchanger in the outdoor unit is being de-iced. |

6 Operation

6.7.5.2 Settings



The menu is only displayed in the Expert level.

| Parameters | Setting |
|-----------------------------|---|
| Idle time | Mandatory shutdown for the outdoor unit after switching off, the compressor will only start again once the time set has elapsed. |
| External sensor allocation | Defines the relevant external sensor for the control. External temperature: External sensor B1 (accessory) [ch. 5.5.1]. Air intake temperature: Air intake sensor (OAT) in outdoor unit. |
| Summer block | Off: Summer block deactivated. -19 ... 40°C: If the external temperature exceeds the value set, the outdoor unit is blocked. Any heat demand while the outdoor unit is blocked must be met by a second heat exchanger. |
| Hibernation mode | The hibernation mode reduces the noise emissions from the outdoor unit over a specific period of time. Off: Hibernation mode deactivated. 75 ... 45%: Maximum load of outdoor unit during hibernation program [ch. 6.7.5.10]. |
| Load limit ET | External temperature, at which the load of the outdoor unit is limited to 80 %. |
| Spread monitoring | Off: Spread monitoring deactivated. On: Monitors the spread of flow and return of the hydraulic unit after defrosting of the outdoor unit. For the defrosting process, a four-way valve installed in the outdoor unit reverses the refrigeration circuit. This means the heat exchanger in the outdoor unit is flushed with heated refrigerant. When the defrosting has been completed, the valve switches back to the normal operating position. Spread monitoring monitors the valve position following defrosting. |
| Dynamic switch differential | On: When the heat pump switches off, the system devices records and saves the spread between flow and return. If the current flow temperature drops below the required flow setpoint temperature by the Dynamic switch differential, The heat pump starts. The Dynamic switch differential is the sum of: <ul style="list-style-type: none"> ▪ the spread saved, ▪ the Switch differential set in menu Heating [ch. 6.7.5.6]. Off: Spread between flow and return is not recorded, the Switch differential set is now used as the switch-on criteria [ch. 6.7.5.6]. |

6 Operation

6.7.5.3 Throughput

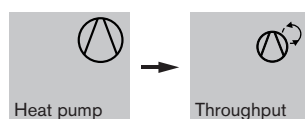

The menu is only displayed in the Expert level.

This parameter only appears, if option `Volumetric flow` has been set under `Switch-on type`, see [ch. 6.7.5.5].

| Parameters | Setting |
|--------------------------------------|--|
| <code>Volumetric flow heating</code> | Defines the volumetric flow for heating operation. |
| <code>Volumetric flow DHW</code> | Defines the volumetric flow for DHW loading. |
| <code>Volumetric flow cooling</code> | Defines the volumetric flow for cooling operation. |

6.7.5.4 Modulation



The menu is only displayed in the Expert level.

Capacity of heat pump during DHW loading.

Automatic:

For DHW loading the capacity modulates on the basis of the flow temperature (10 ... 100 %).

The maximum capacity is limited to 80 %, if the current external temperature is above the `Load limit ET` or the `Hibernation mode` is activated [ch. 6.7.5.2].

50 ... 100%:

During DHW loading the heat pump drives to the capacity set.

The maximum capacity is limited to 80 %, if the current external temperature is above the `Load limit ET` or the `Hibernation mode` is activated [ch. 6.7.5.2].

6 Operation

6.7.5.5 Pump (circulation pump)

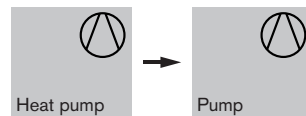

The menu is only displayed in the Expert level.

| Parameters | Setting |
|----------------|--|
| Switch-on type | Operating mode of circulation pump during heating operation. Constant operation: Pump is operated with the Load set. Volumetric flow: The pump modulates depending on the volumetric flow. |
| Load ... | Load of the pump during constant operation. The parameter is only displayed, if the Switch-on type is set to Constant operation . The load can be set individually for operating modes heating, cooling and DHW. |

6.7.5.6 Heating

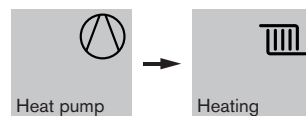

The menu is only displayed in the Expert level.

| Parameters | Setting |
|---------------------|---|
| Switch differential | Switch hysteresis for the heat pump in heating operation. The flow temperature must be below the required flow setpoint temperature by at least the Switch differential to ensure the heat pump starts. If the Dynamic switch differential function is activated, the spread of the flow and return is recorded when the heat pump is switched off and added to the Switch differential, see [ch. 6.7.5.2]. |
| Load limit | Upper limit for heat pump capacity in heating operation. |

6.7.5.7 Cooling

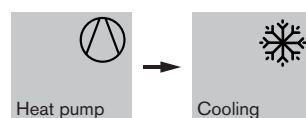

The menu is only displayed in the Expert level.

| Parameters | Setting |
|---------------------|--|
| Switch differential | Switch hysteresis for the heat pump in cooling operation. The flow setpoint temperature required must be below the current flow temperature by at least the Switch differential to ensure the heat pump starts. |
| Load limit | Upper limit for heat pump capacity in cooling operation. |

6 Operation

6.7.5.8 Domestic hot water

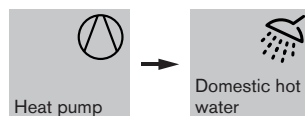

The menu is only displayed in the Expert level.

| Parameters | Setting |
|---------------------|---|
| Switch differential | If the temperature in the storage tank drops below the DHW setpoint temperature by the switch differential, DHW loading is initiated. |

6.7.5.9 Reset

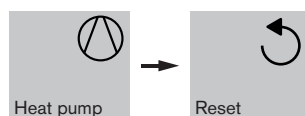

The menu is only displayed in the Expert level.

Reset all changes made in the heat pump menu to factory settings.

6.7.5.10 Hibernation program



The menu is only displayed in the Expert level.

The hibernation program is activated via the load default in parameter `Hibernation mode`, see [ch. 6.7.5.2].

In the hibernation program, 3 time cycles are preset for each weekday. The hibernation program can be adapted individually, the procedure is the same as for the time programs [ch. 6.4.3].

6 Operation

6.7.6 Second heat exchanger

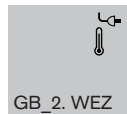

The menu is only displayed in the Expert level.

Second heat exchangers are:

- internal electric heating
- flange heating in the storage tank (optional)
- solar system and buffer storage (optional)
- condensing unit (optional)

| Parameters | Setting |
|-------------------------|---|
| Limit temperature | <p>Off: No limit temperature defined.</p> <p>-20 ... +40 °C: If the current external temperature drops below the value set, the heat pump is blocked and only the second external heat exchanger (e.g. condensing unit) is activated.</p> |
| Bivalent temperature | <p>-20 ... +40 °C: If the current external temperature drops below the value set, the second heat exchanger can be activated. Bivalent operation (parallel operation) of heat pump and second heat exchanger is possible.</p> |
| Fault release | <p>Off: Fault release deactivated. If a fault occurs in the heat pump, the second heat exchanger is also blocked.</p> <p>On: If a fault occurs in the heat pump, the second heat exchanger continues to operate.</p> |
| Switch-on differential | <p>If the current flow temperature drops below the flow setpoint temperature by the value set, the second heat exchanger switches on once the <code>Switch-on delay</code> has elapsed.</p> |
| Switch-on delay | <p>Switch-on delay of second heat exchanger. The <code>Switch-on differential</code> must be maintained for the duration of the time set, before the second heat exchanger switches on.</p> |
| Switch-off differential | <p>If the current flow temperature exceeds the flow setpoint temperature by the value set, the second heat exchanger switches off once the <code>Switch-off delay</code> has elapsed.</p> |
| Switch-off delay | <p>Switch-off delay of second heat exchanger. The <code>Switch-off differential</code> must be maintained for the duration of the time set, before the second heat exchanger switches off.</p> |

6 Operation



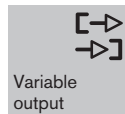

6.7.7 Variable output



The menu is only displayed in the Expert level.

The variable output can be defined for various functions. The scope of the submenu is displayed depending on the definition.

Parameters Setting

| | |
|---|---|
|  Info | <p>Shows the function of the variable output currently selected.</p> |
|  Circulation pump | <p>Mode: Determines if the output is <code>Off</code> or if it is controlled time-dependent during DHW loading (<code>Time</code>).</p> <p>Time period: Duration of cycle</p> <p>Pause: Off time during a cycle.</p> <p>Example:</p> <ul style="list-style-type: none"> ▪ Time period: 15 min ▪ Pause: 5 min ▪ Run time pump: ON = 10 min, OFF = 5 min |
|  Time programs | <p>In the time program for the timer function, one time cycle is preset for each weekday. The time program can be adapted individually, the procedure is the same as for the time programs [ch. 6.4.3].</p> |
|  Settings | <p>Determines the function of the variable output.</p> <p>Off: No function, is not controlled.</p> <p>Circulation pump: Output is periodically controlled during the DHW program.</p> <p>Ext. heating circuit pump: Output is controlled in the heating mode of the heat pump.</p> <p>Timer: Output is controlled to time program.</p> <p>Fault message: Output is controlled if a fault occurs in the heat pump.</p> <p>Cooling operation: Output is controlled in the cooling mode of the heat pump.</p> <p>Compressor operation: Output is controlled in compressor operation of the heat pump.</p> <p>DHW operation: Output is controlled during DHW loading.</p> <p>Continuous voltage: Output is controlled when the hydraulic unit is switched on.</p> |
|  Reset | <p>Reset all changes made in menu Variable output to factory settings.</p> |

6 Operation

6.7.8 Settings

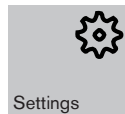

| Parameters | Setting |
|------------|---|
| | Set current time of day. |
| | Set current date. |
| | Configure automatic change-over of summertime. <ul style="list-style-type: none"> ▪ On (factory setting) ▪ Off |
| | Adjust the brightness of the display. |
| | Deactivate the light strip on the hydraulic unit. <ul style="list-style-type: none"> ▪ On (factory setting): Light strip activated. ▪ Off: Light strip deactivated. |
| | Set language. |

6.7.9 Fault memory

6.7.9.1 Fault memory



The menu is only displayed in the Expert level.

The last 20 faults are recorded in menu Fault history.

7 Commissioning

7 Commissioning

7.1 Prerequisite

Commissioning must only be carried out by qualified personnel.

Only correctly carried out commissioning ensures the operational safety.

Commissioning must only be carried out once the cooling circuit has been installed completely (see installation and operating manual of outdoor unit).

- ▶ Prior to commissioning ensure that:
 - all assembly and installation work has been carried out correctly,
 - the unit and the system have been filled with media and vented,
 - cooling or heating demand exists,
 - the service valves on the outdoor unit are open.

Additional system-related tests could be necessary. Please observe the operating guidelines for the individual components.

7 Commissioning

7.2 Steps for commissioning

1. Rinse sludge separator

- ▶ Close flow and return shut off devices of heating circuit.
- ▶ Close flow and return shut off devices of hot water circuit.
- ▶ Provide collecting container.
- ▶ Remove end cap ④ from sludge separator ①.
- ▶ Attach the enclosed angle ② (with hose) to the sludge separator.
- ▶ Open the tap ③ with the end cap and rinse the sludge separator.
- ▶ Refill water quantity via rinsing device:
System pressure = inlet pressure + 0.5 bar.

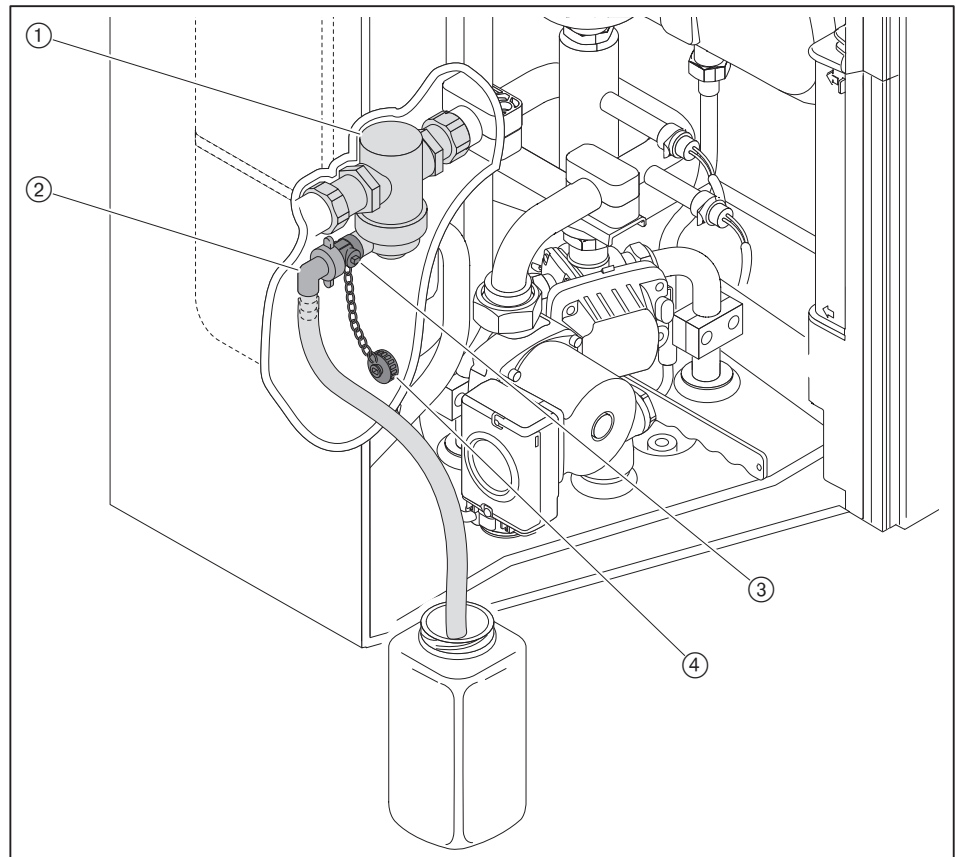

7 Commissioning

2. Switch on voltage supply

- ▶ Apply voltage to the outdoor unit/system using fusing provided on site.



Damage to the condenser because electric heating has not been connected
The condenser can freeze, if the supply temperature drops to much during commissioning.

- ▶ Connect electric heating and switch on voltage supply [ch. 5.5].
- ▶ Select the electric heating as second heat exchanger on the display and operating unit.

3. Start the commissioning assistant

- ▶ Switch on system at switch S1 [ch. 5.5].
- ✓ The commissioning assistant starts automatically if the system has not yet been configured.
- ✓ The display shows *Commissioning*.
- ▶ Press dial knob.

If the system has already been configured:

- ▶ Select expert level [ch. 6.6].
- ▶ Select *Commissioning* and confirm.

System not configured

Commissioning via expert level

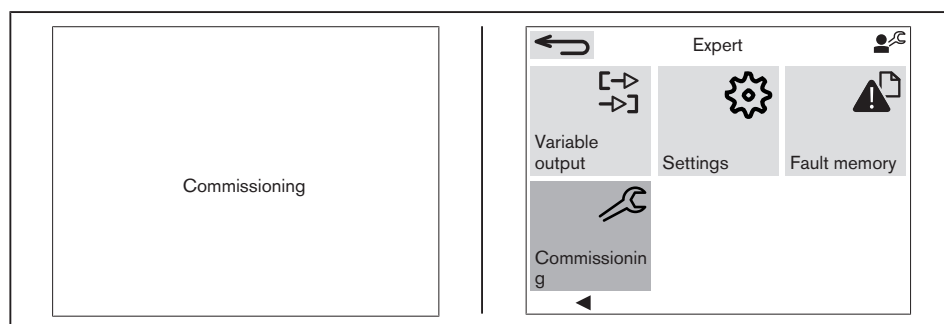

4. Set language

- ▶ Select language required and confirm.
- ✓ The language selected is generated.

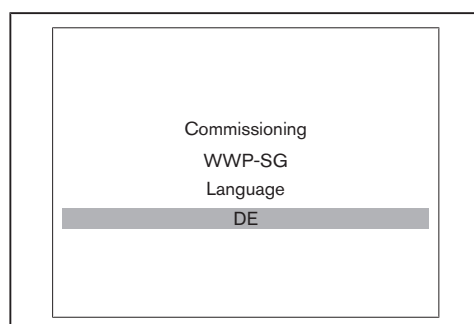

7 Commissioning

5. Set date and time

- ▶ Set current date and confirm.
- ▶ Set current time of day.

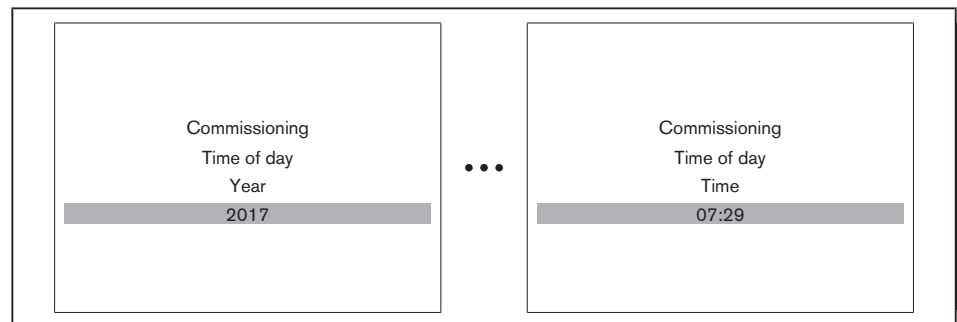

6. Set heat pump function

- ▶ Set heat pump operating mode and confirm.
 - HP+E1: Heat pump operation supported by stage 1 of electric heating in the hydraulic unit.
 - HP+E2: Heat pump operation supported by stage 2 of electric heating in the hydraulic unit.
 - HP+E1+E2: Heat pump operation supported by stage 1 and 2 of electric heating in the hydraulic unit.
 - HP+HEX: Heat pump operation supported by the second heat exchanger, e. g. condensing unit. Electric heating in the hydraulic unit is deactivated.

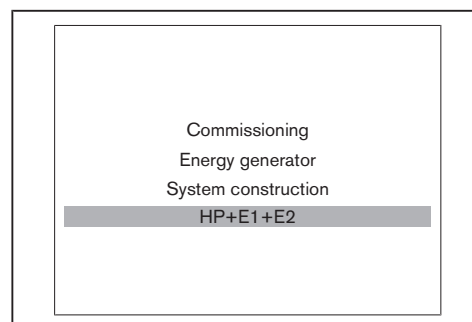

7 Commissioning

7. Set function DHW operation

- ▶ Set mode for DHW loading and confirm.
 - OFF: No DHW loading by heat pump, heating operation only.
 - HP: DHW loading with heat pump via three way valve in hydraulic unit.
 - HP with flange heating: DHW loading with heat pump via three way valve in hydraulic unit. From an adjustable temperature level, the flange heater in the storage tank carries out DHW loading.

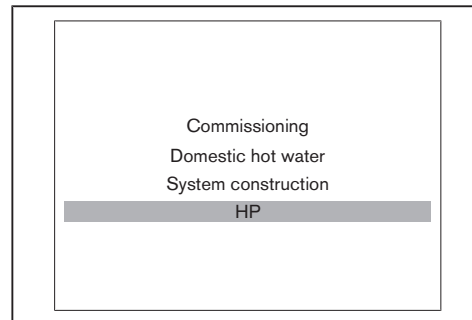

8. Set heating circuit function

- ▶ Set heating circuit and confirm.
 - OFF: No heating circuit connected.
 - ON: Heat pump supplies heating circuit.

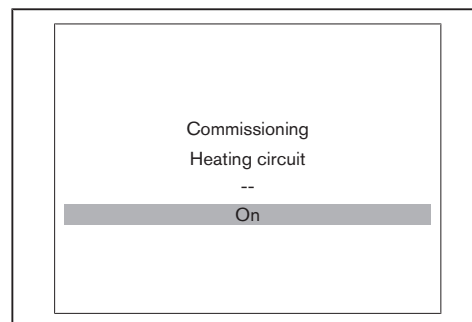

9. Set function of variable output

- ▶ Set function of variable output and confirm [ch. 6.7.7].
- ✓ This setting can be adjusted after commissioning.

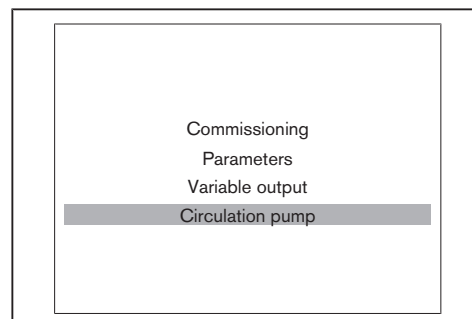

7 Commissioning

10. Set circulation pump capacity

- ▶ Set circulation pump capacity [ch. 6.7.5.5].
 - Cooling capacity is not displayed during commissioning, cooling operation has to be released first [ch. 6.7.3.7].
 - The pump capacity can be adjusted after commissioning.

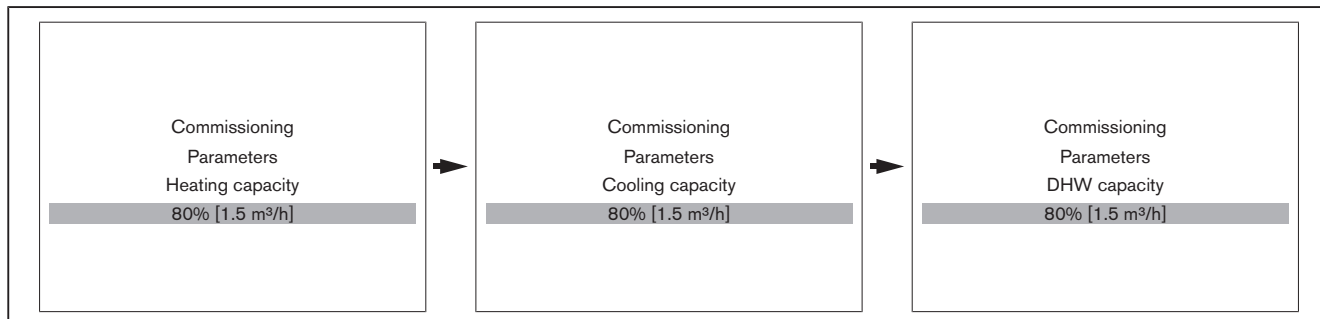

If commissioning is repeated with a different pump switch-on type, a query regarding the volumetric flow appears instead of the pump capacity [ch. 6.7.5.5].

11. Check volumetric flow of heating water

- ▶ Check volumetric flow of heating water.
- ▶ If necessary set the overflow valve with flow sensor to minimum nominal flow [ch. 3.4.5].

12. Concluding work

- ▶ Fit service cover.
- ▶ Mount the front panel and secure the tension lock with the screw.
- ▶ Inform the operator about the use of the equipment.
- ▶ Hand the installation and operating manual to the operator and inform him that this should be kept with the appliance.
- ▶ Point out to operator that the installation should be serviced annually.
- ▶ Document all work carried out on the engineers report.

8 Shutdown

8 Shutdown

For breaks in operation:

- ▶ Interrupt voltage supply.
- ▶ If there is a risk of frost, drain the water from the system.



If refrigerant is to be pumped into the outdoor unit do not interrupt voltage supply.

9 Servicing

9 Servicing

9.1 Notes on servicing



Risk of electric shock

Working on the device when voltage is applied can lead to electric shock.

- ▶ Isolate hydraulic unit and outdoor unit from power supply prior to carrying out work.
 - ▶ Safeguard against accidental restart.
-



Risk of electric shock

Working on the device when voltage is applied can lead to electric shock.

The electric heating in the hydraulic unit is equipped with a separate voltage supply.

- ▶ Isolate the electric heating from the power supply prior to starting any work.
 - ▶ Safeguard against accidental restart.
-



Risk of suffocation due to leaking refrigerant

Leaking refrigerant collects at the base of the unit. Inhalation may cause suffocation, and even death. Contact with the skin can cause frostbite.

- ▶ Do not damage refrigeration circuit.
-



Danger of getting burned on hot components

Hot components can lead to burns.

- ▶ Allow components to cool.
-



Environmental damage due to leaking refrigerant

Refrigerant contains fluorinated greenhouse gases in accordance with the Kyoto Protocol and must not be discharged into the atmosphere.

- ▶ Do not damage refrigeration circuit.
-

Servicing must only be carried out by qualified personnel. The unit should be serviced annually. Depending on site conditions more frequent checks may be required.

For devices containing fluorinated greenhouse gases from a quantity of 5 Tonnes CO₂ equivalent, a soundness test in accordance with EU regulation 517/2014 must be carried out and documented at least every 12 months [ch. 3.4.7].



Weishaupt recommends a service contract is entered into to ensure regular inspections.

Prior to every servicing

- ▶ Inform the operator about the extent of service work to be carried out.
- ▶ Switch off installation and safeguard against accidental re-start.
- ▶ Remove front panel [ch. 4.2].

9 Servicing

Following servicing

Observe national regulations for soundness test of refrigerant circuit.

- ▶ Carry out visual inspection:
 - check pipe connections,
 - check refrigerant pipework and insulation for visible damage,
 - complete insulation of refrigerant pipework.
- ▶ If necessary replace damaged refrigerant pipework and insulation.
- ▶ Check for leaks using a leak detecting device during operation.
- ▶ Carry out a function test.
- ▶ Document all work carried out on the engineers report.
- ▶ Mount the front panel and secure the tension lock with the screw.

9 Servicing

9.2 Service work

Observe notes on servicing [ch. 9.1].

- ▶ Check condensate drain and clean if necessary.
- ▶ Rinse sludge separator [ch. 9.5].
- ▶ Check vent valve (visual check).
- ▶ Check heating water pressure [ch. 3.4.6].
- ▶ Check inlet pressure in the expansion vessel and adjust if necessary [ch. 12.1].

Working on the refrigerant pipe pipework

Observe operating pressure of refrigerant [ch. 3.4.6].

The hydraulic unit is equipped with an additional Schrader valve ①.

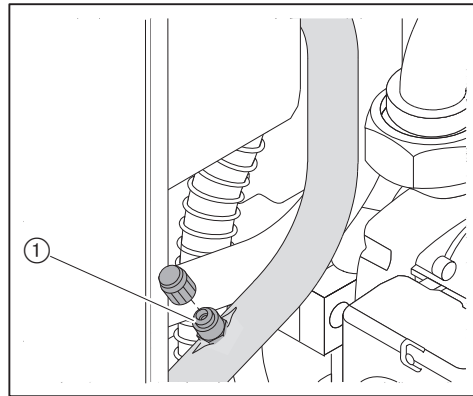

Work on the refrigerant pipework can be carried out either on the outdoor unit or on the hydraulic unit, e.g.:

- checking for leaks,
- evacuating refrigerant pipework,
- filling refrigerant.

9 Servicing

9.3 Removing and refitting expansion vessel

Observe notes on servicing [ch. 9.1].

Removing

- ▶ Close flow and return shut off devices of heating circuit.
- ▶ Close flow and return shut off devices of hot water circuit.
- ▶ Drain hydraulic unit using the outlet tap.
- ✓ Hydraulic unit is depressurised.
- ▶ Remove operating unit:
 - Open cover ②.
 - Remove splash guard ⑤.
 - Unplug electrical connections.
 - Open upper cover on slot ③ and remove.
 - Open lower cover on slot ④ and remove.
 - Remove screws and remove operating unit ①.

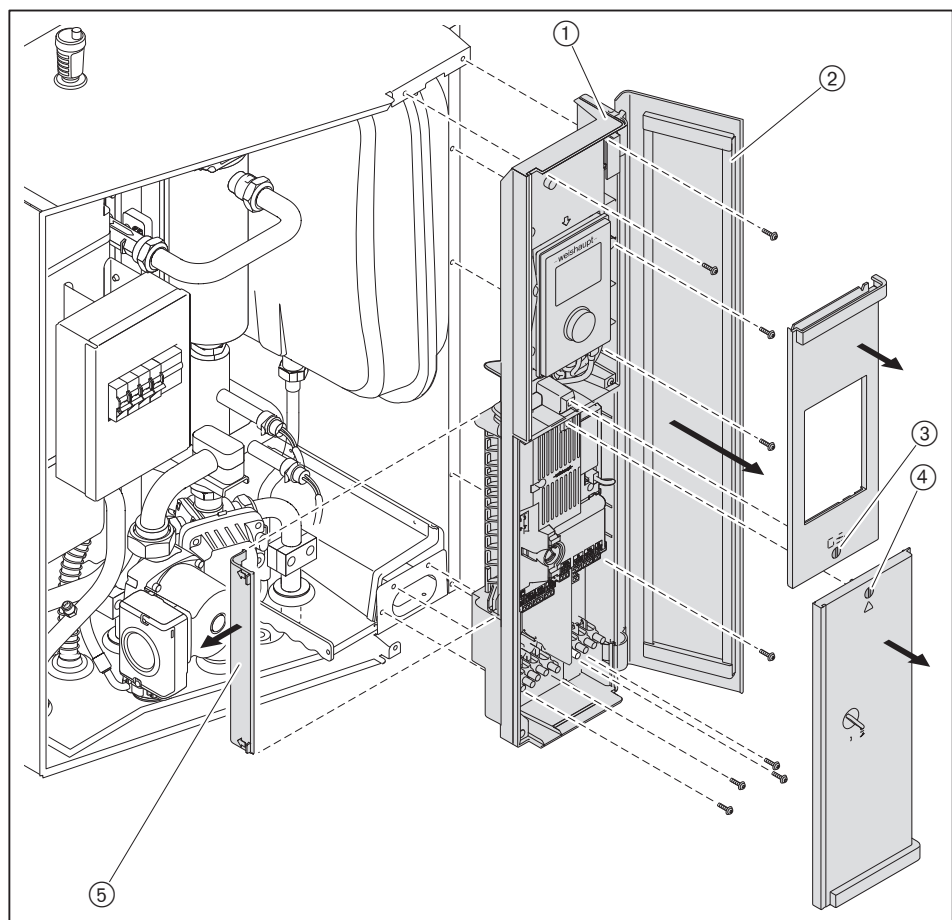

9 Servicing

- ▶ Separate connection hose ② from expansion vessel.
- ▶ Remove locking screw ①

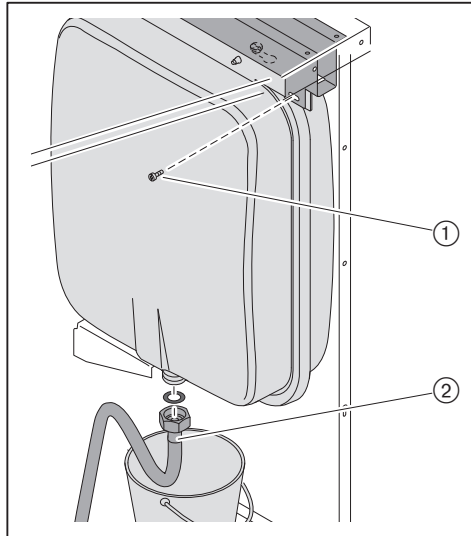

- ▶ Remove screws ③ and remove bracket ②.
- ▶ Pull expansion vessel ① to the front.

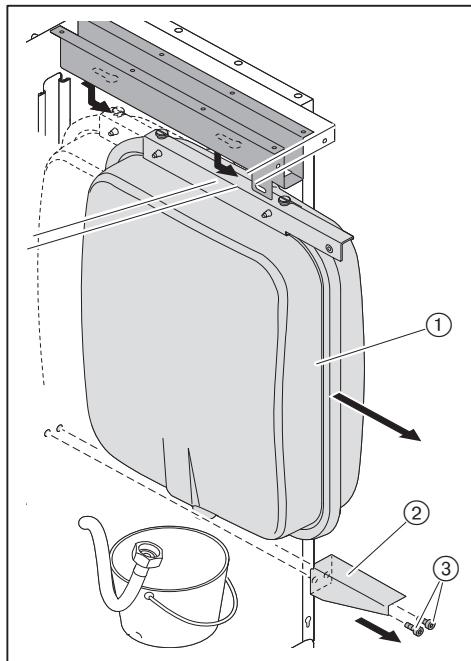

Refitting

- ▶ Refit expansion vessel in reverse order, at the same time replace washer ①.

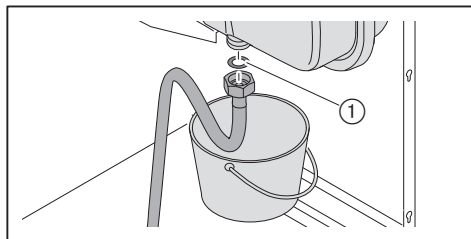

9 Servicing

9.4 Replace safety valve

Observe notes on servicing [ch. 9.1].

Removing

- ▶ Close flow and return shut off devices of heating circuit.
- ▶ Close flow and return shut off devices of hot water circuit.
- ▶ Drain hydraulic unit using the outlet tap.
- ✓ Hydraulic unit is depressurised.
- ▶ Remove drainage hose ②.
- ▶ Remove safety valve ①.

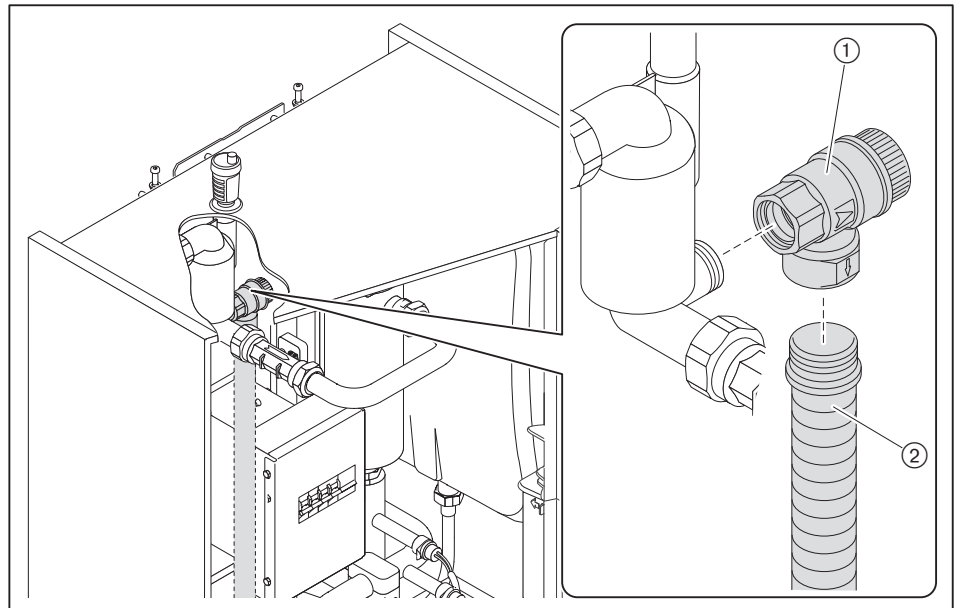

Refitting

- ▶ Install the safety valve using suitable sealing material.
- ▶ Connect outlet hose.

9 Servicing

9.5 Rinse sludge separator

Observe notes on servicing [ch. 9.1].

- ▶ Close flow and return shut off devices of heating circuit.
- ▶ Close flow and return shut off devices of hot water circuit.
- ▶ Provide collecting container.
- ▶ Remove end cap ④ from sludge separator ①.
- ▶ Attach the enclosed angle ② (with hose) to the sludge separator.
- ▶ Open the tap ③ with the end cap and rinse the sludge separator.
- ▶ Refill water quantity via rinsing device:
System pressure = inlet pressure + 0.5 bar.

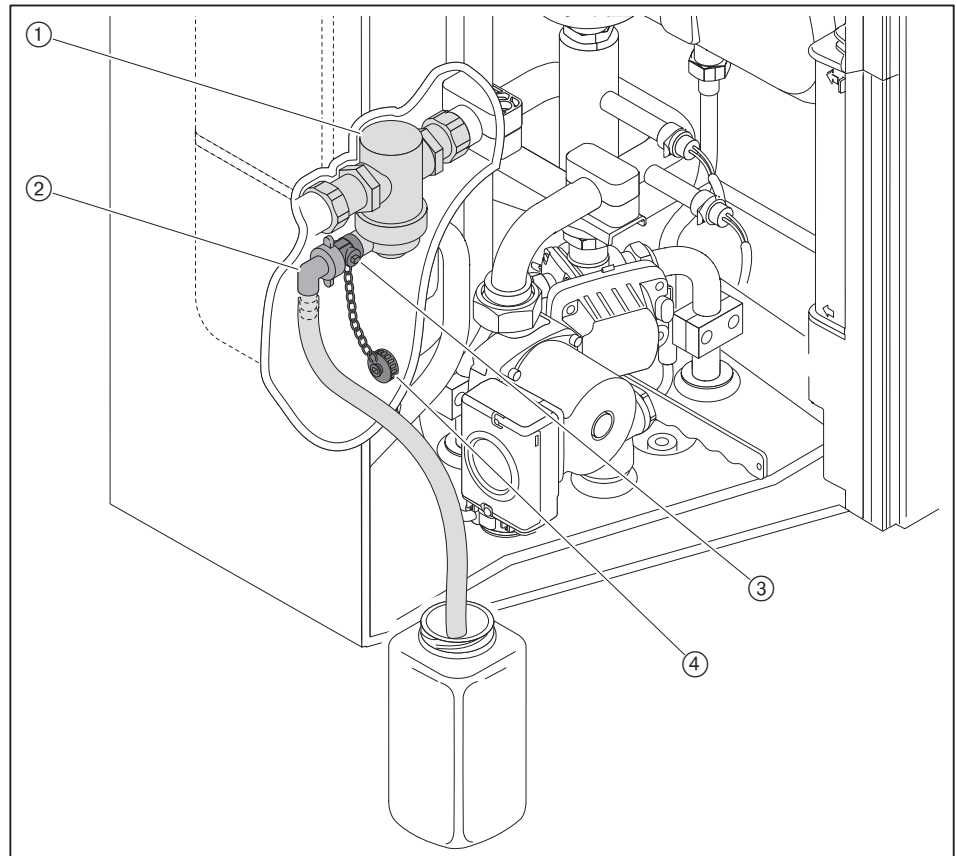

10 Troubleshooting

10 Troubleshooting

10.1 Procedures for fault conditions

- Voltage supply available.
- Heating switch is set to On.
- System device has been set correctly.

The system device detects and displays irregularities in the system.

The following conditions can occur:

- Warning
- Fault

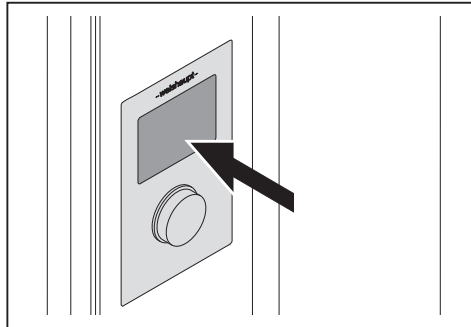

Warnings

The unit does not lock out during a warning. The signal will extinguish automatically as soon as the cause of the warning has been eliminated.

Example

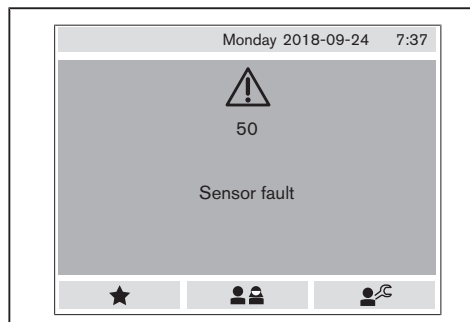

If a warning appears more than once, the system should be checked by qualified personnel.

- ▶ Read and correct the warning [ch. 10.2].

10 Troubleshooting

Faults

If a fault occurs, the systems goes to lockout, if operational safety can no longer be ensured.

If the system is in lockout, the display shows `Reset`.

Example

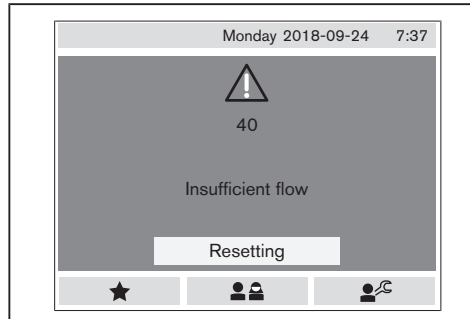

Faults must only be rectified by qualified personnel.

- ▶ Read and correct the fault [ch. 10.2].

Resetting



Damage resulting from incorrect servicing

Heat pump could be damaged.

- ▶ Do not carry out more than 2 lockout resets successively.
- ▶ Faults must be rectified by qualified personnel.

- ▶ Select `Reset` and confirm.
- ✓ The system is reset.

10 Troubleshooting

10.2 Fault codes

Outdoor unit

The following faults must only be rectified by qualified personnel:

| Warning | Cause | Rectification |
|---------|---|--|
| 1 | Heat exchanger sensor OU inlet (OCT) defective | ▶ Check the sensor and cable and replace if necessary |
| 2 | Compressed gas temperature sensor (CTT) defective | ▶ Check the sensor and cable and replace if necessary |
| 3 | Temperature sensor in inverter (HST) defective | ▶ Check the sensor and cable and replace if necessary |
| 4 | Air intake sensor (OAT) defective | ▶ Check the sensor and cable and replace if necessary |
| 5 | Heat exchanger sensor OU centre (OMT) defective | ▶ Check the sensor and cable and replace if necessary |
| 8 | Pressure downstream of compressor too high | Normally no action is required. Troubleshooting is only required, if the problem occurs several times within one hour. ▶ Check the refrigerant level. ▶ Check actuator of expansion vessel, replace if necessary ▶ Check service valves |
| 9 | Pressure upstream of heat exchanger in outdoor unit too low | Normally no action is required. Troubleshooting is only required, if the problem occurs several times within one hour. ▶ Check the refrigerant level. ▶ Check soundness of cooling circuit ▶ Check actuator of expansion vessel, replace if necessary |
| 10 | No communication with the inverter | ▶ Check voltage supply to the inverter ▶ Check connection cable |
| 11 | Compressor overcurrent | ▶ Check intake air area ▶ Check fan |
| 13 | Cooling circuit leaking | ▶ Check cooling circuit |
| 14 | DC over or under-voltage | ▶ Check voltage supply |
| 15 | AC over or under-voltage | ▶ Check voltage supply |
| 16 | Outdoor unit and hydraulic unit not compatible | ▶ Check type |
| 17 | Communication error | ▶ Check BUS line |
| 18 | Outdoor unit overloaded | – |
| 19 | Fault on frequency converter of outdoor unit | ▶ Check voltage supply |
| 20 | Evaporator (heat exchanger) overheats | ▶ Check intake air area ▶ Check fan |
| 21 | Defrost activated | Normally no action is required. Troubleshooting is only required, if the problem occurs several times within one hour. ▶ Check cooling circuit |
| 22 | Compressor overheats | Normally no action is required. Troubleshooting is only required, if the problem occurs several times within one hour. ▶ Check cooling circuit |

10 Troubleshooting

The following faults must only be rectified by qualified personnel:

| Warning | Cause | Rectification |
|---------|--|---|
| 23 | Power consumption of compressor motor too high | Normally no action is required. Troubleshooting is only required, if the problem occurs several times within one hour. ▶ Check cooling circuit |
| 24 | Fan does not run | Check fan, if necessary replace |
| 26 | Compressor blocked | Check fan, if necessary replace |
| 28 | Impermissible operating condition | ▶ Briefly isolate the outdoor unit from voltage supply ▶ If the fault persists despite restart, check circuit board in outdoor unit and replace if necessary |
| 29 | Internal cooling sensor (B8) or heat exchanger pressure sensor (B12) defective | ▶ Check the sensor and cable and replace if necessary |
| 30 | Condenser overheats | Normally no action is required. Troubleshooting is only required, if the problem occurs several times within one hour. ▶ Check cooling circuit |
| 31 | Application limit exceeded | – |
| 40 | Insufficient flow Minimum volumetric flow: ▪ WWP LS 8: 0.8 m ³ /h ▪ WWP LS 10: 1.0 m ³ /h ▪ WWP LS 13: 1.2 m ³ /h ▪ WWP LS 16: 1.3 m ³ /h | ▶ Check shut off device ▶ Check thermostatic valves of heating circuit ▶ Check flow sensor, if necessary replace |
| 41 | Flow/return spread of heating circuit to great | ▶ Increase volumetric flow ▶ Increase pump capacity |
| 42 | Pressure at internal heat exchanger pressure sensor (B12) to high. | ▶ Check the refrigerant level. ▶ Check actuator of expansion vessel, replace if necessary |
| 47 | No voltage supply to outdoor unit / blocked by energy generator | ▶ Wait for release by energy generator ▶ Check voltage supply |
| 50 / 51 | External sensor (B1) defective | ▶ Check the sensor and cable and replace if necessary |
| 52 / 53 | De-couple sensor (B2) defective | |
| 54 / 55 | DHW sensor (B3) defective | |
| 56 / 57 | Flow sensor (B10) defective | ▶ Check cable, if necessary replace sensor |
| 58 / 59 | Flow sensor electric heating (B7) defective | ▶ Check the sensor and cable and replace if necessary |
| 60 / 61 | Internal refrigerant sensor (B8) defective | |
| 62 / 63 | Return sensor EWT (B9) defective | |
| 64 / 65 | Flow sensor (B10) defective | ▶ Check cable, if necessary replace sensor |
| 66 / 67 | Internal heat exchanger pressure sensor (B12) defective | |
| 68 | Flow sensor (B10) signal fault | ▶ Check cable, if necessary replace sensor |
| 98 / 99 | Internal fault | – |

11 Technical documentation

11 Technical documentation

11.1 Sensor variables

De-couple sensor (B2)

DHW sensor (B3)

Flow sensor (B7)⁽¹⁾

Internal refrigerant sensor
(B8)

Return sensor EWT (B9)

External sensor (B1)⁽²⁾

Flow sensor LWT (B4)⁽³⁾

| NTC 5 kΩ | | NTC 2 kΩ | | PT 1000 kΩ | |
|----------|--------|----------|--------|------------|-------|
| °C | Ω | °C | Ω | °C | Ω |
| -20 | 48 180 | -20 | 15 138 | -10 | 961 |
| -15 | 36 250 | -15 | 11 709 | 0 | 1 000 |
| -10 | 27 523 | -10 | 9 138 | 10 | 1 039 |
| -5 | 21 078 | -5 | 7 193 | 20 | 1 078 |
| 0 | 16 277 | 0 | 5 707 | 30 | 1 117 |
| 5 | 12 669 | 5 | 4 563 | 40 | 1 155 |
| 10 | 9 936 | 10 | 3 675 | 50 | 1 194 |
| 15 | 7 849 | 15 | 2 981 | 60 | 1 232 |
| 20 | 6 244 | 20 | 2 434 | 70 | 1 271 |
| 25 | 5 000 | 25 | 2 000 | 80 | 1 309 |
| 30 | 4 029 | 30 | 1 653 | 90 | 1 347 |
| 35 | 3 267 | 35 | 1 375 | | |
| 40 | 2 665 | 40 | 1 149 | | |
| 45 | 2 185 | | | | |
| 50 | 1 802 | | | | |
| 55 | 1 494 | | | | |
| 60 | 1 245 | | | | |
| 65 | 1 042 | | | | |
| 70 | 876 | | | | |
| 75 | 740 | | | | |
| 80 | 628 | | | | |
| 85 | 535 | | | | |
| 90 | 457 | | | | |

⁽¹⁾ Flow temperature downstream of electric heating.

⁽²⁾ Accessory

⁽³⁾ Flow temperature between electric heating and internal heat exchanger (sensor integrated in flow sensor).

Internal heat exchanger pressure sensor (B12)

| bar | mA |
|------|----|
| 0 | 4 |
| 7.5 | 6 |
| 15.0 | 8 |
| 22.5 | 10 |
| 30.0 | 12 |
| 37.5 | 14 |
| 45.0 | 16 |
| 60.0 | 20 |

11 Technical documentation

11.2 Smart-Grid

With the Smart-Grid function (SG Ready), the heat pump can be operated with electricity supplied by a photovoltaic system.

Switching conditions

Observe wiring diagram [ch. 5.5].

The Smart-Grid function offers the following possibilities:

| Operating mode | Function | Input H1 | Input H2 |
|---|--|----------|----------|
| 1: Block (EVU block) | Heating operation and DHW loading blocked, frost protection is provided. | closed | open |
| 2: Normal operation | DHW loading and heating operation are controlled to setpoint temperature. | open | open |
| 3: Increased operation (over-supply of electricity) | The <i>SG Ready increase</i> is added to the flow setpoint temperature in the heating circuit and the DHW setpoint temperature. The increase for: <ul style="list-style-type: none"> ▪ heating operation ▪ DHW loading [ch. 6.7.4.5] | open | closed |
| 4: Forced operation (over-supply of electricity) | Heat pump and electric heating are in operation in heating mode until the respective maximum temperature has been reached. | closed | closed |

12 Project planning

12 Project planning

12.1 Expansion vessel and system pressure

The unit is equipped with an integrated expansion vessel:

- Contents 18 litres,
- inlet pressure 0.75 bar.

- ▶ Use the following table to verify whether an additional expansion vessel should be installed.

Example

A maximum flow temperature of 50 °C and an installation elevation of 7.5 metres would result in a maximum system content of 500 litres. An additional expansion vessel must be installed if this volume is exceeded.

| | Installation elevation | | | | |
|------------------|---|-------|------|--------|------|
| | 5 m | 7.5 m | 10 m | 12.5 m | 15 m |
| Flow temperature | Maximum admissible total water content [litres] | | | | |
| max 40 °C | 820 | 700 | 620 | 420 | 300 |
| max 50 °C | 620 | 500 | 410 | 280 | 190 |
| max 60 °C | 440 | 360 | 290 | 190 | 140 |

Expansion vessel inlet pressure

The inlet pressure is calculated from the static ceiling of the system:

10 metres static height = 1.0 bar inlet pressure

The static height is determined by the difference in height between the expansion vessel connection and the highest point of the system.

If the static height is less than 5 metres (e. g. with a one-storey building or roof heating centre), an inlet pressure of minimum 0.5 bar must be selected.

If the hydraulic unit is installed at a higher point of the building (e. g. in the loft), the inlet pressure should also be set to minimum 0.5 bar.

- ▶ Determine static height.
- ▶ Calculate inlet pressure.
- ▶ Check inlet pressure in the expansion vessel and adjust to calculated value if necessary.

System pressure

- ▶ Set the system pressure 0.5 bar above the adjusted inlet pressure of the expansion vessel.

Example

| | Example 1 | Example 2 |
|---------------------------------|-----------|-----------|
| Static height | 8 metres | 1 metre |
| Expansion vessel inlet pressure | 0.8 bar | 0.5 bar |
| System pressure | 1.3 bar | 1.0 bar |

13 Key word index

| | | | |
|-------------------------------------|--------------------|--|--------------------|
| A | | E-heating..... | 43 |
| Air intake temperature..... | 42 | Electric heating..... | 12, 13, 28, 30, 43 |
| Air separator..... | 11 | Electrical connection..... | 27 |
| Air throughput..... | 15 | Electrical data | 14 |
| Ambient conditions..... | 15 | Empty weight | 19 |
| Approval data..... | 14 | Energy generation..... | 44 |
| B | | EVU block..... | 29, 82 |
| Bivalent temperature | 60 | Expansion vessel..... | 11, 83 |
| Block..... | 82 | Expert level | 40 |
| Bracket..... | 22 | External heating circuit pump..... | 61 |
| Breaks in operation..... | 69 | External sensor | 48, 56 |
| Brightness | 62 | External temperature | 41 |
| Building construction..... | 49 | F | |
| Building insulation..... | 49 | Fabrication number..... | 10 |
| Bus line..... | 27 | Factory setting..... | 51, 54, 59 |
| C | | Fault code..... | 78 |
| Capacity graph cooling | 17 | Fault codes..... | 79 |
| Capacity graph heating | 16 | Fault history..... | 62 |
| Change-over valve..... | 11, 13, 41 | Fault message..... | 61 |
| Circulation pump..... | 12, 13, 18, 58, 61 | Fault release..... | 60 |
| Clearance | 21 | Faults | 78, 79 |
| Coefficient of performance..... | 15 | Favourites | 34 |
| Commissioning..... | 63 | Filling with water | 25 |
| Compressor frequency..... | 42 | Fixed value | 48 |
| Condensate..... | 26 | Flange heater | 67 |
| Condenser..... | 11, 13 | Flange heating | 54 |
| Conformity certification | 2 | Flow..... | 24, 80 |
| Constant operation..... | 58 | Flow sensor..... | 12, 13 |
| Constant temperature..... | 48 | Flow setpoint temperature..... | 47, 49, 55 |
| Consumption..... | 14 | Flow setpoint temperature DHW | 53 |
| Contrast | 62 | Flow temperature | 15, 17, 49 |
| Cooling capacity | 17 | Frequency..... | 42 |
| Cooling mode..... | 50 | Frost | 47 |
| Cooling reference line..... | 50 | Frost protection | 48 |
| Cooling water flow temperature..... | 17 | Function DHW operation..... | 67 |
| COP..... | 15 | G | |
| D | | Gradient | 47 |
| Date..... | 62 | Guarantee..... | 7 |
| De-couple temperature | 41 | H | |
| Defrost..... | 55 | Heat capacity..... | 15 |
| Demand..... | 48 | Heat pump function..... | 66 |
| Demand increase | 49 | Heating..... | 45, 58 |
| DHW..... | 59 | Heating characteristic curve..... | 47 |
| DHW loading | 54, 57, 67 | Heating circuit | 67 |
| DHW program | 34, 37, 52 | Heating circuit flow temperature | 41 |
| DHW Push | 34, 52 | Heating circuit pump..... | 12 |
| DHW setpoint temperature | 34, 52, 53 | Heating curve..... | 47 |
| DHW temperature | 41 | Heating pause | 46 |
| Dial knob | 32 | Heating program | 34, 37, 49 |
| Display..... | 32, 33, 62 | Heating water | 23 |
| Disposal | 9 | Heating water flow rate | 15 |
| Dynamic switch differential..... | 41, 56 | Heating water flow temperature | 15 |
| E | | Hibernation mode | 56 |
| EER | 17 | Hibernation program | 59 |
| Efficiency ratio | 17 | Humidity | 15 |
| | | Hydraulic connection | 24 |

13 Key word index

| | | | |
|-------------------------------|------------|-------------------------------------|----------------|
| I | | R | |
| Idle time | 56 | Refrigerant | 9 |
| Illumination | 62 | Refrigerant leakage..... | 8 |
| Info..... | 41 | Refrigerant pipework..... | 25 |
| Inlet pressure | 83 | Refrigerant temperature | 42 |
| Installation..... | 21 | Refrigeration circuit | 9 |
| Installation elevation | 83 | Reset..... | 51, 54, 59, 78 |
| Installation location | 15, 21 | Resulting supply pressure | 18 |
| L | | Return | 24 |
| Language | 62, 65 | Return flow sensor..... | 12 |
| Legionella protection..... | 53 | Return temperature..... | 41 |
| Level..... | 33 | Roof heating centre..... | 83 |
| Liability..... | 7 | Room setpoint temperature..... | 34, 47 |
| Light bar | 31 | Room size | 21 |
| Light strip | 62 | S | |
| Limit temperature | 60 | Safety measures..... | 8 |
| Load demand | 41 | Safety valve | 11, 26, 75 |
| Load limit..... | 56, 57, 58 | Schrader valve | 72 |
| Lockout..... | 78, 79 | Screed | 48 |
| M | | Second heat exchanger (2. HEX)..... | 60 |
| Mains voltage | 14 | Second heat exchanger (2. WEZ)..... | 43 |
| Manual defrost..... | 55 | Second heat exchanger (HEX)..... | 60 |
| Maximum temperature..... | 49 | Second heat exchanger (WEZ)..... | 43 |
| Minimum clearance..... | 21 | Sensor | 12 |
| Minimum room volume | 21 | Sensor variables..... | 81 |
| Minimum temperature | 49 | Serial number | 10 |
| Minimum volumetric flow | 80 | Service..... | 55 |
| Modulation | 57 | Service connection..... | 11 |
| N | | Service contract | 70 |
| Name plate | 10 | Setback mode | 48 |
| O | | Setpoint temperature | 34, 47 |
| Operating cycles..... | 42 | SG Ready | 48, 53, 82 |
| Operating hours | 42 | Shutdown | 69 |
| Operating mode | 45 | Shutdown time | 69 |
| Operating panel | 32 | Sludge separator | 11, 13 |
| Operating phase | 42 | Smart-Grid..... | 48, 53, 82 |
| Operating pressure | 19 | Software version | 41 |
| Operating unit..... | 32 | Speed | 41 |
| Operational display..... | 31 | Spread monitoring | 56 |
| Operational status | 31 | Standards | 14 |
| Outdoor unit..... | 42 | Standby | 45 |
| Overview | 11, 12 | Start screen..... | 33 |
| P | | Statistic | 44 |
| Party | 46 | Storage..... | 15 |
| Password | 40 | Summer | 45 |
| Pause..... | 46 | Summer block..... | 56 |
| Photovoltaic..... | 82 | Summer/Winter | 49 |
| Pump..... | 58 | Summertime | 62 |
| Q | | Switch differential | 58 |
| Quick action vent valve..... | 11 | Switch differential DHW | 59 |
| | | Switch-off delay | 60 |
| | | Switch-off differential | 60 |
| | | Switch-on delay..... | 60 |
| | | Switch-on differential | 60 |
| | | Switch-on type | 58 |
| | | System device | 32 |
| | | System operating mode | 45 |
| | | System pressure | 25, 83 |

13 Key word index

T

Temperature 15
Three way valve 11, 13, 41
Throughput 57
Time of day 62
Time program 34, 37
Timer 61
Transport 15
Type 42
Type key 10
Type of protection 14

U

User level 39













V

Vaporiser temperature 42
Variable output 61
Venting 55
Voltage supply 14
Volume flow rate 15
Volumetric flow 41, 57, 58

W

Wall bracket 22
Warning code 77
Warnings 77
Water connection 24
Water quantity 25
Weather compensated 48
Weight 19
Wiring diagram 29

The complete program: Reliable technology and prompt, professional service

| | | | |
|---|---|---|---|
|  | <p>W Burners up to 570 kW</p> <p>The compact burners, proven millions of times over, are economical and reliable. Available as gas, oil and dual fuel burners for domestic and commercial applications.</p> <p>The purflam® burner version with special mixing head gives almost soot-free combustion of oil with greatly reduced NOx emissions.</p> | <p>Wall-hung condensing boilers for gas up to 240 kW</p> <p>The wall-hung condensing boilers WTC-GW have been developed to meet the highest demands in ease of operation and efficiency. Modulating operation means these units operate quietly and economically.</p> |  |
|  | <p>monarch® WM Burners and Industrial Burners up to 11,700 kW</p> <p>These legendary industrial burners are durable and versatile.</p> <p>Numerous variations of oil, gas and dual fuel burners meet a wide range of applications and capacity requirements.</p> | <p>Floor standing condensing boiler for oil and gas up to 1,200 kW</p> <p>The floor-standing boilers WTC-GB and WTC-OB are efficient, low in emissions and versatile. Higher capacities are achieved by cascading up to four gas-fired condensing boilers.</p> |  |
|  | <p>WK Burners up to 32,000 kW</p> <p>These industrial burners of modular construction are adaptable, robust and powerful.</p> <p>Even on the toughest industrial applications these oil, gas and dual fuel burners operate reliably.</p> | <p>Solar systems</p> <p>The stylish flat-plate collectors are the ideal complement for any Weishaupt heating system. They are suitable for solar water heating and for combined heating support.</p> <p>With versions for on-roof, in-roof and flat roof installations, solar energy can be utilised on almost any roof.</p> |  |
|  | <p>multiflam® Burners up to 23,000 kW</p> <p>This innovative Weishaupt technology for medium and large burners provides minimum emission values at capacities up to 17 MW.</p> <p>The burners with the patented mixing head are available for oil, gas and dual fuel operation.</p> | <p>Water heaters / energy storage tanks</p> <p>This attractive program for domestic water heating includes classic water heaters, solar storage tanks, heat pump storage tanks and energy storage tanks.</p> |  |
|  | <p>MCR Technology / Building Automation from Neuberger</p> <p>From control panels to complete building management systems - at Weishaupt you can find the entire spectrum of modern control technology. Future orientated, economical and flexible.</p> | <p>Heat pumps up to 180 kW</p> <p>The heat pump range offers solutions for the utilisation of heat from the air, the soil or ground water.</p> <p>Some systems are also suitable for cooling buildings.</p> |  |
|  | <p>Service</p> <p>Weishaupt customers can be assured that specialist knowledge and tools are available whenever they are needed. Our service engineers are fully qualified and have extensive product knowledge, be it for burners, heat pumps, condensing boilers or solar collectors.</p> | <p>Geothermal probe drilling</p> <p>With its daughter company, BauGrund Süd, Weishaupt also offers geothermal probe and well drilling. With the experience of more than 10,000 systems and more than 2 million meters of drilling, BauGrund Süd offers a comprehensive service program.</p> |  |